Mullard technical handbook

Book one

Semiconductor devices

Part three

Diodes

January 1981



Mullard

Book 1 Part 3

Diodes

January 1981



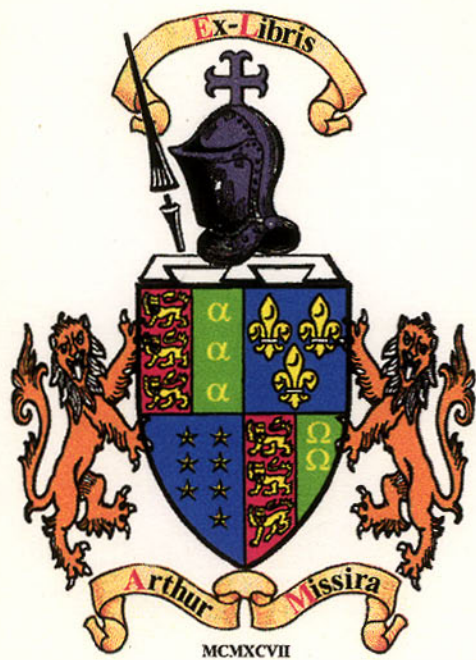

DIODES

CONTENTS

SELECTION GUIDE	BS 9000, CECC approved types	
GENERAL SECTION		A
SILICON WHISKERLESS DIODES		B
VOLTAGE REGULATOR DIODES	(Low power)	C
VOLTAGE REFERENCE DIODES		D
RECTIFIER DIODES	(Low power)	E
GERMANIUM DIODES	Point contact Gold bonded	F
TUNER DIODES		G
SPECIAL TYPE		H
INDEX		

The issue of the information contained in this publication does not imply any authority or licence for the utilisation of any patented feature.

'Mullard' is the trademark of Mullard Limited and is registered in most of the principal countries of the world.

©Mullard Limited 1981

Book 1 comprises the following parts—

- | | |
|---------|---|
| Part 1A | Small-signal transistors |
| Part 1B | Low-frequency power transistors |
| Part 1C | Field-effect transistors |
| Part 1D | Microminiature semiconductors for hybrid circuits |
| Part 2 | R.F. power devices |
| Part 3 | Diodes |
| Part 4 | Power diodes, thyristors, triacs |
| Part 5 | Discontinued (combined with Part 4) |
| Part 6A | } See new Book 4 (Integrated circuits) |
| Part 6B | |
| Part 7A | |
| Part 7B | |
| Part 8 | Microwave semiconductors and components |
| Part 9 | Opto-electronic devices |



BOOK 1 (Part 3)

SEMICONDUCTOR DEVICES

Diodes

Mullard manufacture and market electronic components under the **Mullard**, **Philips** and **Signetics** brands.

MULLARD LTD., MULLARD HOUSE, TORRINGTON PLACE,
LONDON, WC1E 7HD

Telephone 01-580 6633

Telex: 264341

DATA HANDBOOK SYSTEM

The Mullard data handbook system is made up of four sets of books, each comprising several parts; plus the Signetics technical handbooks.

The four sets of books, easily identifiable by the colours on their covers, are as follows:

Book 1	(blue)	Semiconductor devices.
Book 2	(orange)	Valves and tubes.
Book 3	(green)	Passive components, materials and assemblies.
Book 4	(purple)	Integrated circuits.

Each part is completely reviewed annually; revised and reprinted where necessary. Revisions to previous data are indicated by an arrow in the margin.

The data contained in these books are as accurate and up to date as it is reasonably possible to make them at the time of going to press. It must however be understood that no guarantee can be given here regarding the availability of the various devices or that their specifications may not be changed before the next edition is published.

The devices on which full data are given in these books are those around which we would recommend equipment to be designed. Where appropriate, other types no longer recommended for new equipment designs, but generally available for equipment production are listed separately with abridged data. Data sheets for these types may be obtained on request. Older devices on which data may still be obtained on request are also included in the index of the appropriate part of each book.

Requests for information on the data handbook system (including Signetics data) and for individual data sheets should be made to

Technical Publications Department
Mullard Limited
New Road
Mitcham
Surrey CR4 4XY
Telex: 22194

Information regarding price and availability of devices must be obtained from our authorised agents or from our representatives.

Products approved to BS9000 and CECC available on request:

	Specification No.	Type No.
BS9000	BS9305 – N041	BZY88 series
	BS9305 – F0087	BZY88 series
CECC	CECC 50 001 – 020	CV8308, CV8805
	CECC 50 001 – 021	{ BAW62 CV7367, CV7368, CV7756 CV7757, CV8617, CV9637 1N914, 1N916, 1N4148 1N4446, 1N4448
	CECC 50 001 – 022	{ BAV18, BAV19, BAV20, BAV21 BAX16, BAX17 CV8790
	CECC 50 001 – 026	{ BA314 PO33
	CECC 50 001 – 037	CV9638
	CECC 50 001 – 038	CV7875
	CECC 50 005 – 005	{ BZX79 series CV7138 to CV7146 CV7099 to CV7106
	CECC 50 008 – 015	{ BYW54, BYW55, BYW56 CVA7026 to CVA7030 CVA7476



WHISKERLESS DIODES

DO-35 outline; quoted values are max.

	type	V_R V	I_F mA	I_{FRM} mA	t_{rr} ns	C_d pF	V_F at I_F V mA
general purpose	BA316	10	100	225	4	2	1.1 100
	BA317	30	100	225	4	2	1.1 100
	BA318	50	100	225	4	2	1.1 100
	OA200	50	160	250	3.5	25	1.15 30
	OA202	150	160	250	3.5	25	1.15 30
	1N914	75	75	225	4	4	1 10
	1N916	75	75	225	4	2	1 10
general purpose avalanche	BAS11	300	350	2000	1000	10 typ.	1.1 300
high-speed switching; general purpose	BAW62	75	200	450	4	2	1 100
	1N4148	75	200	450	4	4	1 10
	1N4446	75	200	450	4	4	1 20
	1N4448	75	200	450	4	4	1 100
high-speed core-gating	BAV10	60	300	600	6	2.5	1.25 500
high speed; high voltage	BAV18	50	250	625	50	5	1.25 200
	BAV19	100	250	625	50	5	1.25 200
	BAV20	150	250	625	50	5	1.25 200
	BAV21	200	250	625	50	5	1.25 200
general industrial	BAX13	50	75	150	4	3	1.53 75
	BAX16	150	200	300	120	10	1.5 200
	BAX17	200	200	300	120	10	1.2 200
avalanche for telephony	BAX12A	90	400	800	50	35	1 200



VOLTAGE REGULATOR DIODES

Stabistors

type	working voltage (nom.) V	P_{tot} at T_{amb}		I_{FRM} max. mA	case
		max. mW	$^{\circ}\text{C}$		
BA314	0.7	—	—	250	DO-35
BZV46-1V5	1.5	250	55	120	DO-35
BZV46-2V0	2	250	55	80	DO-35

Voltage regulator diodes (small signal, low power)

type	working voltage range V	P_{tot} at T_{amb}		I_{FRM} max. mA	case
		max. mW	$^{\circ}\text{C}$		
BZV85	5.1 to 75	1300	25	250	DO-41
BZX61*	7.5 to 130	1300	25	1000	DO-15
	150 to 200	1000	25	1000	DO-15
BZX79	2.4 to 75	400	50	250	DO-35
BZX87	5.1 to 75	1750	25	400	SOD-51
BZY88	2.7 to 33	400	50	250	DO-7

* Available for current production only; not recommended for new designs.



VOLTAGE REFERENCE DIODES

DO-35 outline; voltage tolerance $\pm 5\%$

type	reference voltage at I_Z		$I_{ZM \max}$ (I_{ZRM}) mA	S_Z %/°C	at I_Z mA	r_{diff} at I_Z	
	V (nom)	mA				Ω	mA
BZX90				<0.01			
BZX91				<0.005			
BZX92	6.5	7.5	50	<0.002	7.5	15	7.5
BZX93				<0.001			
BZX94				<0.0005			
1N821				<0.01			
1N823				<0.005			
1N825	6.2	7.5	50	<0.002	7.5	15	7.5
1N827				<0.001			
1N829				<0.0005			
BZV10				<0.01			
BZV11				<0.005			
BZV12	6.5	2	50	<0.002	2	50	2
BZV13				<0.001			
BZV14				<0.0005			



RECTIFIER DIODES

General purpose	type	$I_{F(AV)}$ max mA	V_{RRM} max V	outline
	BYX10	360	1600	DO-14
	*BYX36—	1000	150 300 600	DO-15
	1N4001	1000	50	DO-15
	1N4002		100	
	1N4003		200	
	1N4004		400	
	1N4005		600	
	1N4006		800	
	1N4007		1000	
Controlled avalanche	BYW54	2000	600	SOD-57
	BYW55	2000	800	SOD-57
	BYW56	2000	1000	SOD-57
Fast soft-recovery	*BY206	400	350	DO-14/DO-15
	*BY207	400	600	DO-14/DO-15
	*BY210—	1000	400 600 800	DO-15
	BYX55—	1200	350 600	SOD-18
	BYV95A	1500	200	SOD-57
	B		400	
	C		600	
	BYV96D	1500	800	SOD-57
	E		1000	
	BYW95A	3000	200	SOD-64
	B		400	
	C		600	
	BYW96D	3000	800	SOD-64
	E		1000	
Ultra fast soft-recovery	BYV27—	2000	50 100 150 200	SOD-57
	BYV28—	3500	50 100 150 200	SOD-64

* Available for current production only; not recommended for new designs.



RECTIFIER DIODES (Cont.)

Parallel efficiency

type	$I_{FWM} \text{ max}$ A	$V_{RRM} \text{ max}$ V	outline
BY448	4	1500	SOD-57
BY458	4	1200	SOD-57
BY228	5	1500	SOD-64
BY438	5	1200	SOD-64

E.H.T. soft-recovery

type	$I_{F(AV)} \text{ max}$ mA	$V_{RRM} \text{ max}$ kV	outline
BY409	2.5	12.5	SOD-34
BY476	2.5	18	SOD-56
BY509	4	12.5	SOD-61
BY184	5	1.8	SOD-34
BYX90	200	7.5	SOD-18B
BYX91-90k	200	115	L < 143 mm
-120k	200	150	< 171 mm
-150k	200	190	< 231 mm
-180k	200	225	< 231 mm



*GERMANIUM SMALL SIGNAL DIODES

Point contact

Quoted values are max.

	type	V_R V	I_F mA	I_{FRM} mA	V_F V at	I_F mA
general purpose	OA90	20	8	45	1.5	10
	OA91	90	50	150	1.9	10
	OA95	90	50	150	1.5	10
a.m. and f.m. detection	AA119	30	35	100	2.2	10

Gold bonded

	type	V_R V	I_F mA	I_{FRM} mA	t_{rr} ns	C_d pF	V_F V at	I_F mA
general purpose	AAZ13	8	30	50	—	2	1.0	30
	AAZ15	75	140	250	—	2	1.1	250
	AAZ17	50	140	250	—	2	1.1	250
general purpose and switching	OA47	25	110	150	70	3.5	1.1	150

*Available for current production only; not recommended for new designs.



TUNER DIODES

Variable capacitance diodes	type	envelope	V_R max. V	C_d at V_R		C_d ratio at V_R	
				pF	V	.V/.V	
a.f.c.	BB119	DO-35	15	20 - 25	4	> 1.3	4/10
radio f.m. band II	BB110B*	SOD-23	30	29 - 33	3	> 2.5	3/30
	BB110G*	SOD-23	30	27 - 31	3	> 2.5	3/30
radio a.m. bands	BB212	TO-92	12	500-620	0.5	> 23	0.5/8
television v.h.f.							
band I to 88 MHz	BB809	DO-34	28	4.5-6	25	> 5	3/25
band III to 230 MHz	BB405G	DO-34	28	1.8-2.5	25	> 4.3	3/25
	BB105G*	SOD-23	28	1.8-2.8	25	> 4.0	3/25
television u.h.f.							
band IV and V to 860 MHz	BB105B*	SOD-23	28	2.0-2.3	25	> 4.5	3/25
	BB405B	DO-34	28	2.0-2.3	25	> 4.8	3/25
Band switching diodes						r_D at I_F	
						(Ω)	(mA)
I.f. switching	BA223	DO-35	20	< 3.5	6	< 1.5	10
	BA182*	SOD-23	35	< 1.0	20	< 0.7	5
v.h.f. switching	BA243	DO-35	20	< 2.0	15	< 1.0	10
	BA244	DO-35	20	< 2.0	15	< 0.5	10
	BA482	DO-34	35	< 1.2	3	< 0.7	3
	BA483	DO-34	35	< 1.0	3	< 1.2	3
V.H.F. — U.H.F. mixer diode	BA280	SOD-23	4	< 1.0	0	< 15	5
Attenuator (p-i-n diode)	BA379	SOD-52	30	= 0.3	0	< 6.5	10

All television varicaps will be supplied in matched sets.

Over the voltage range 0.5 V to 28 V the diodes in a unit are capacitance matched to within 3%: BB105B; BB405B; BB405G;

6%: BB105G

*Available for current production only; not recommended for new designs.



GENERAL SECTION

Type designation

Rating systems

Letter symbols

Colour codes

Packing

Mounting and soldering

A





PRO ELECTRON TYPE DESIGNATION CODE FOR SEMICONDUCTOR DEVICES

This type designation code applies to discrete semiconductor devices — as opposed to integrated circuits —, multiples of such devices and semiconductor chips.

A basic type number consists of:

TWO LETTERS FOLLOWED BY A SERIAL NUMBER

FIRST LETTER

The first letter gives information about the material used for the active part of the devices.

- A. GERMANIUM or other material with band gap of 0,6 to 1,0 eV.
- B. SILICON or other material with band gap of 1,0 to 1,3 eV.
- C. GALLIUM-ARSENIDE or other material with band gap of 1,3 eV or more.
- R. COMPOUND MATERIALS (e.g. Cadmium-Sulphide).

SECOND LETTER

The second letter indicates the function for which the device is primarily designed.

- A. DIODE; signal, low power
- B. DIODE; variable capacitance
- C. TRANSISTOR; low power, audio frequency ($R_{th j-mb} > 15 \text{ }^\circ\text{C/W}$)
- D. TRANSISTOR; power, audio frequency ($R_{th j-mb} \leq 15 \text{ }^\circ\text{C/W}$)
- E. DIODE; tunnel
- F. TRANSISTOR; low power, high frequency ($R_{th j-mb} > 15 \text{ }^\circ\text{C/W}$)
- G. MULTIPLE OF DISSIMILAR DEVICES — MISCELLANEOUS; e.g. oscillator
- H. DIODE; magnetic sensitive
- L. TRANSISTOR; power, high frequency ($R_{th j-mb} \leq 15 \text{ }^\circ\text{C/W}$)
- N. PHOTO-COUPLER
- P. RADIATION DETECTOR; e.g. high sensitivity phototransistor
- Q. RADIATION GENERATOR; e.g. light-emitting diode (LED)
- R. CONTROL AND SWITCHING DEVICE; e.g. thyristor, low power ($R_{th j-mb} > 15 \text{ }^\circ\text{C/W}$)
- S. TRANSISTOR; low power, switching ($R_{th j-mb} > 15 \text{ }^\circ\text{C/W}$)
- T. CONTROL AND SWITCHING DEVICE; e.g. thyristor, power ($R_{th j-mb} \leq 15 \text{ }^\circ\text{C/W}$)
- U. TRANSISTOR; power, switching ($R_{th j-mb} \leq 15 \text{ }^\circ\text{C/W}$)
- X. DIODE; multiplier, e.g. varactor, step recovery
- Y. DIODE; rectifying, booster
- Z. DIODE; voltage reference or regulator (transient suppressor diode, with third letter W)

TYPE DESIGNATION

SERIAL NUMBER

Three figures, running from 100 to 999, for devices primarily intended for consumer equipment. One letter (Z, Y, X, etc.) and two figures, running from 10 to 99, for devices primarily intended for industrial/professional equipment.

This letter has no fixed meaning except W, which is used for transient suppressor diodes.

VERSION LETTER

It indicates a minor variant of the basic type either electrically or mechanically. The letter never has a fixed meaning, except letter R, indicating reverse voltage, e.g. collector to case or anode to stud.

SUFFIX

Sub-classification can be used for devices supplied in a wide range of variants called associated types. Following sub-coding suffixes are in use:

1. VOLTAGE REFERENCE and VOLTAGE REGULATOR DIODES: *ONE LETTER and ONE NUMBER*

The LETTER indicates the nominal tolerance of the Zener (regulation, working or reference) voltage

A. 1% (according to IEC 63: series E96)

B. 2% (according to IEC 63: series E48)

C. 5% (according to IEC 63: series E24)

D. 10% (according to IEC 63: series E12)

E. 20% (according to IEC 63: series E6)

The number denotes the typical operating (Zener) voltage related to the nominal current rating for the whole range.

The letter 'V' is used instead of the decimal point.

2. TRANSIENT SUPPRESSOR DIODES: *ONE NUMBER*

The NUMBER indicates the maximum recommended continuous reversed (stand-off) voltage V_R . The letter 'V' is used as above.

3. CONVENTIONAL and CONTROLLED AVALANCHE RECTIFIER DIODES and THYRISTORS: *ONE NUMBER*

The NUMBER indicates the rated maximum repetitive peak reverse voltage (V_{RRM}) or the rated repetitive peak off-state voltage (V_{DRM}), whichever is the lower. Reversed polarity is indicated by letter R, immediately after the number.

4. RADIATION DETECTORS: *ONE NUMBER*, preceded by a hyphen (-)

The NUMBER indicates the depletion layer in μm . The resolution is indicated by a version LETTER.

5. ARRAY OF RADIATION DETECTORS and GENERATORS: *ONE NUMBER*, preceded by a stroke (/).

The NUMBER indicates how many basic devices are assembled into the array.

RATING SYSTEMS

The rating systems described are those recommended by the International Electrotechnical Commission (IEC) in its Publication 134.

DEFINITIONS OF TERMS USED

Electronic device. An electronic tube or valve, transistor or other semiconductor device.

Note

This definition excludes inductors, capacitors, resistors and similar components.

Characteristic. A characteristic is an inherent and measurable property of a device. Such a property may be electrical, mechanical, thermal, hydraulic, electro-magnetic, or nuclear, and can be expressed as a value for stated or recognized conditions. A characteristic may also be a set of related values, usually shown in graphical form.

Bogey electronic device. An electronic device whose characteristics have the published nominal values for the type. A bogey electronic device for any particular application can be obtained by considering only those characteristics which are directly related to the application.

Rating. A value which establishes either a limiting capability or a limiting condition for an electronic device. It is determined for specified values of environment and operation, and may be stated in any suitable terms.

Note

Limiting conditions may be either maxima or minima.

Rating system. The set of principles upon which ratings are established and which determine their interpretation.

Note

The rating system indicates the division of responsibility between the device manufacturer and the circuit designer, with the object of ensuring that the working conditions do not exceed the ratings.

ABSOLUTE MAXIMUM RATING SYSTEM

Absolute maximum ratings are limiting values of operating and environmental conditions applicable to any electronic device of a specified type as defined by its published data, which should not be exceeded under the worst probable conditions.

These values are chosen by the device manufacturer to provide acceptable serviceability of the device, taking no responsibility for equipment variations, environmental variations, and the effects of changes in operating conditions due to variations in the characteristics of the device under consideration and of all other electronic devices in the equipment.

The equipment manufacturer should design so that, initially and throughout life, no absolute maximum value for the intended service is exceeded with any device under the worst probable operating conditions with respect to supply voltage variation, equipment component variation, equipment control adjustment, load variations, signal variation, environmental conditions, and variations in characteristics of the device under consideration and of all other electronic devices in the equipment.

DESIGN MAXIMUM RATING SYSTEM

Design maximum ratings are limiting values of operating and environmental conditions applicable to a bogey electronic device of a specified type as defined by its published data, and should not be exceeded under the worst probable conditions.

These values are chosen by the device manufacturer to provide acceptable serviceability of the device, taking responsibility for the effects of changes in operating conditions due to variations in the characteristics of the electronic device under consideration.

The equipment manufacturer should design so that, initially and throughout life, no design maximum value for the intended service is exceeded with a bogey device under the worst probable operating conditions with respect to supply voltage variation, equipment component variation, variation in characteristics of all other devices in the equipment, equipment control adjustment, load variation, signal variation and environmental conditions.

DESIGN CENTRE RATING SYSTEM

Design centre ratings are limiting values of operating and environmental conditions applicable to a bogey electronic device of a specified type as defined by its published data, and should not be exceeded under normal conditions.

These values are chosen by the device manufacturer to provide acceptable serviceability of the device in average applications, taking responsibility for normal changes in operating conditions due to rated supply voltage variation, equipment component variation, equipment control adjustment, load variation, signal variation, environmental conditions, and variations in the characteristics of all electronic devices.

The equipment manufacturer should design so that, initially, no design centre value for the intended service is exceeded with a bogey electronic device in equipment operating at the stated normal supply voltage.

LETTER SYMBOLS FOR TRANSISTORS AND SIGNAL DIODES

based on IEC Publication 148

LETTER SYMBOLS FOR CURRENTS, VOLTAGES AND POWERS

Basic letters

The basic letters to be used are:

I, i = current
V, v = voltage
P, p = power.

Lower-case basic letters shall be used for the representation of instantaneous values which vary with time.

In all other instances upper-case basic letters shall be used.

Subscripts

A, a	Anode terminal
(AV), (av)	Average value
B, b	Base terminal, for MOS devices: Substrate
(BR)	Breakdown
C, c	Collector terminal
D, d	Drain terminal
E, e	Emitter terminal
F, f	Forward
G, g	Gate terminal
K, k	Cathode terminal
M, m	Peak value
O, o	As third subscript: The terminal not mentioned is open circuited
R, r	As first subscript: Reverse. As second subscript: Repetitive. As third subscript: With a specified resistance between the terminal not mentioned and the reference terminal.
(RMS), (rms)	R. M. S. value
S, s	{ As first or second subscript: Source terminal (for FETS only) As second subscript: Non-repetitive (not for FETS) As third subscript: Short circuit between the terminal not mentioned and the reference terminal
X, x	Specified circuit
Z, z	Replaces R to indicate the actual working voltage, current or power of voltage reference and voltage regulator diodes.

Note: No additional subscript is used for d. c. values.

Upper-case subscripts shall be used for the indication of:

- a) continuous (d. c.) values (without signal)
Example I_B
- b) instantaneous total values
Example i_B
- c) average total values
Example $I_{B(AV)}$
- d) peak total values
Example I_{BM}
- e) root-mean-square total values
Example $I_{B(RMS)}$

Lower-case subscripts shall be used for the indication of values applying to the varying component alone:

- a) instantaneous values
Example i_b
- b) root-mean-square values
Example $I_{b(rms)}$
- c) peak values
Example I_{bm}
- d) average values
Example $I_{b(av)}$

Note: If more than one subscript is used, subscript for which both styles exist shall either be all upper-case or all lower-case.

Additional rules for subscripts

Subscripts for currents

Transistors: If it is necessary to indicate the terminal carrying the current, this should be done by the first subscript (conventional current flow from the external circuit into the terminal is positive).

Examples: I_B , i_B , i_b , I_{bm}

Diodes: To indicate a forward current (conventional current flow into the anode terminal) the subscript F or f should be used; for a reverse current (conventional current flow out of the anode terminal) the subscript R or r should be used.

Examples: I_F , I_R , i_F , $I_f(rms)$

Subscripts for voltages

Transistors: If it is necessary to indicate the points between which a voltage is measured, this should be done by the first two subscripts. The first subscript indicates the terminal at which the voltage is measured and the second the reference terminal or the circuit node. Where there is no possibility of confusion, the second subscript may be omitted.

Examples: V_{BE} , v_{BE} , v_{be} , V_{bem}

Diodes: To indicate a forward voltage (anode positive with respect to cathode), the subscript F or f should be used; for a reverse voltage (anode negative with respect to cathode) the subscript R or r should be used.

Examples: V_F , V_R , v_F , V_{rm}

Subscripts for supply voltages or supply currents

Supply voltages or supply currents shall be indicated by repeating the appropriate terminal subscript.

Examples: V_{CC} , I_{EE}

Note: If it is necessary to indicate a reference terminal, this should be done by a third subscript

Example: V_{CCE}

Subscripts for devices having more than one terminal of the same kind

If a device has more than one terminal of the same kind, the subscript is formed by the appropriate letter for the terminal followed by a number; in the case of multiple subscripts, hyphens may be necessary to avoid misunderstanding.

Examples: I_{B2} = continuous (d.c.) current flowing into the second base terminal

V_{B2-E} = continuous (d.c.) voltage between the terminals of second base and emitter

Subscripts for multiple devices

For multiple unit devices, the subscripts are modified by a number preceding the letter subscript; in the case of multiple subscripts, hyphens may be necessary to avoid misunderstanding.

Examples: I_{2C} = continuous (d.c.) current flowing into the collector terminal of the second unit

V_{1C-2C} = continuous (d.c.) voltage between the collector terminals of the first and the second unit.

Application of the rules

The figure below represents a transistor collector current as a function of time. It consists of a continuous (d.c.) current and a varying component.

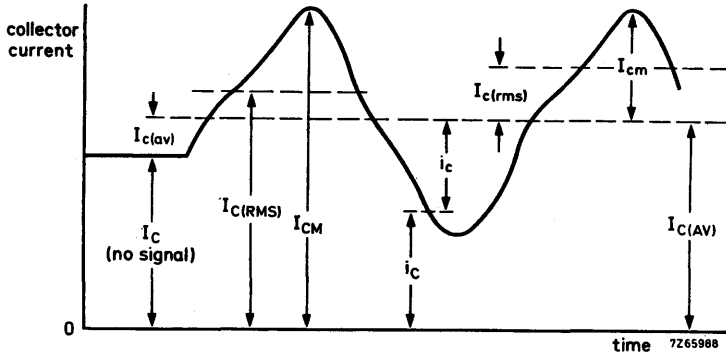

LETTER SYMBOLS FOR ELECTRICAL PARAMETERS

Definition

For the purpose of this Publication, the term "electrical parameter" applies to four-pole matrix parameters, elements of electrical equivalent circuits, electrical impedances and admittances, inductances and capacitances.

Basic letters

The following is a list of the most important basic letters used for electrical parameters of semiconductor devices.

- B, b = susceptance; imaginary part of an admittance
- C = capacitance
- G, g = conductance; real part of an admittance
- H, h = hybrid parameter
- L = inductance
- R, r = resistance; real part of an impedance
- X, x = reactance; imaginary part of an impedance
- Y, y = admittance;
- Z, z = impedance;

Upper-case letters shall be used for the representation of:

- a) electrical parameters of external circuits and of circuits in which the device forms only a part;
- b) all inductances and capacitances.

Lower-case letters shall be used for the representation of electrical parameters inherent in the device (with the exception of inductances and capacitances).

Subscripts

General subscripts

The following is a list of the most important general subscripts used for electrical parameters of semiconductor devices:

F, f	= forward; forward transfer
I, i (or 1)	= input
L, l	= load
O, o (or 2)	= output
R, r	= reverse; reverse transfer
S, s	= source

Examples: Z_S , h_f , h_F

The upper-case variant of a subscript shall be used for the designation of static (d.c.) values.

Examples: h_{FE} = static value of forward current transfer ratio in common-emitter configuration (d.c. current gain)

R_E = d.c. value of the external emitter resistance.

Note: The static value is the slope of the line from the origin to the operating point on the appropriate characteristic curve, i.e. the quotient of the appropriate electrical quantities at the operating point.

The lower-case variant of a subscript shall be used for the designation of small-signal values.

Examples: h_{fe} = small-signal value of the short-circuit forward current transfer ratio in common-emitter configuration

$Z_e = R_e + jX_e$ = small-signal value of the external impedance

Note: If more than one subscript is used, subscripts for which both styles exist shall either be all upper-case or all lower-case

Examples: h_{FE} , y_{RE} , h_{fe}

Subscripts for four-pole matrix parameters

The first letter subscript (or double numeric subscript) indicates input, output, forward transfer or reverse transfer

Examples: h_i (or h_{11})
 h_o (or h_{22})
 h_f (or h_{21})
 h_r (or h_{12})

A further subscript is used for the identification of the circuit configuration. When no confusion is possible, this further subscript may be omitted.

Examples: h_{fe} (or h_{21e}), h_{FE} (or h_{21E})

Distinction between real and imaginary parts

If it is necessary to distinguish between real and imaginary parts of electrical parameters, no additional subscripts should be used. If basic symbols for the real and imaginary parts exist, these may be used.

Examples: $Z_i = R_i + jX_i$
 $y_{fe} = g_{fe} + jb_{fe}$

If such symbols do not exist or if they are not suitable, the following notation shall be used:

Examples: $\text{Re}(h_{ib})$ etc. for the real part of h_{ib}
 $\text{Im}(h_{ib})$ etc. for the imaginary part of h_{ib}

PRO ELECTRON COLOUR CODING SYSTEM FOR PROFESSIONAL SMALL SIGNAL DIODES

Letter combination-background colour

BAV - green
BAW - blue
BAX - black
BAS - orange

Figure combination-colour bands

0 - black
1 - brown
2 - red
3 - orange
4 - yellow
5 - green
6 - blue
7 - violet
8 - grey
9 - white

The cathode side is indicated by a broad band which is at the same time the first digit of the figure combination.

Note: For BA types see individual type publications.

JEDEC assigned type numbers

(EIA-standard RS-236-B; June, 1963)

1. Prefix identification

The prefix identification consisting of a first number symbol and the letter "N" shall not be indicated in the coding.

2. Banding systems

The sequence number consisting of a two, three, or four digit number after the letter "N" may be coded as follows:

2.1 Two-digit sequence numbers shall consist of a first black band and the sequence number in second and third bands of the colours indicated in Table 1. If a suffix letter is required, it shall be indicated with a fourth band as indicated in Table 1.

2.2 Three-digit sequence numbers shall consist of the sequence number in first, second, and third bands of the colours indicated in Table 1. If a suffix letter is required, it shall be indicated with a fourth band as indicated in Table 1.

2.3 Four-digit sequence numbers shall consist of the sequence number in four bands of the colours indicated in Table 1.

If a suffix letter is required it shall be indicated as the fifth band.

3. Cathode identification and reading sequence

3.1 A double-width band shall be used as the first band reading from cathode to anode ends.

3.2 An alternative method is provided where equal width bands may be used. The bands shall be clearly grouped toward the cathode end, and shall be read from cathode to anode ends.

3.3 Either of the above colour banding methods may be used in stead of the cathode designating symbol or other marking.

4. Colour bands

The sequence numbers of the type numbers and suffix letters shall be indicated by the colours in Table 1.

TABLE 1

NUMBER	COLOUR	SUFFIX LETTER
0	black	not applicable
1	brown	A
2	red	B
3	orange	C
4	yellow	D
5	green	E
6	blue	F
7	violet	G
8	grey	H
9	white	J

BANDOLIER AND REEL SPECIFICATION

This specification concerns all axial leaded diodes in this handbook.

The taped and reeled products fulfil the requirements of IEC 286: packaging of components on continuous tapes.

Dimensions in mm

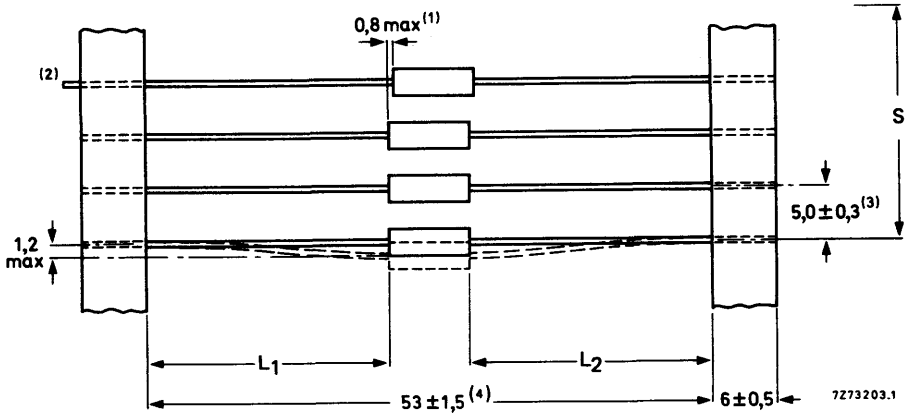

Fig. 1 Configuration of bandolier.

The red tape indicates the diode cathode side.

1. Displacement between any two diodes; for DO-34 maximum 0,4.
2. For SOD-18, $10 \pm 0,5$.
3. For outlines SOD-34, SOD-56 and SOD-61 this dimension is 58 ± 2 .

The cumulative space (S) measured over ten spacings = 50 ± 2 , and for SOD-18 specified as 100 ± 2 .

The diodes are centred so that $|L_1 - L_2| \leq 1,2 \text{ mm}$. DO-14 not specified.

On the white tape of the bandolier per 50 diodes a black marker is printed.

The axial taping specification described above is compatible with automatic insertion equipment as manufactured by Universal, U.S.M. (Dynapert) and M.E.I. (Panaset).

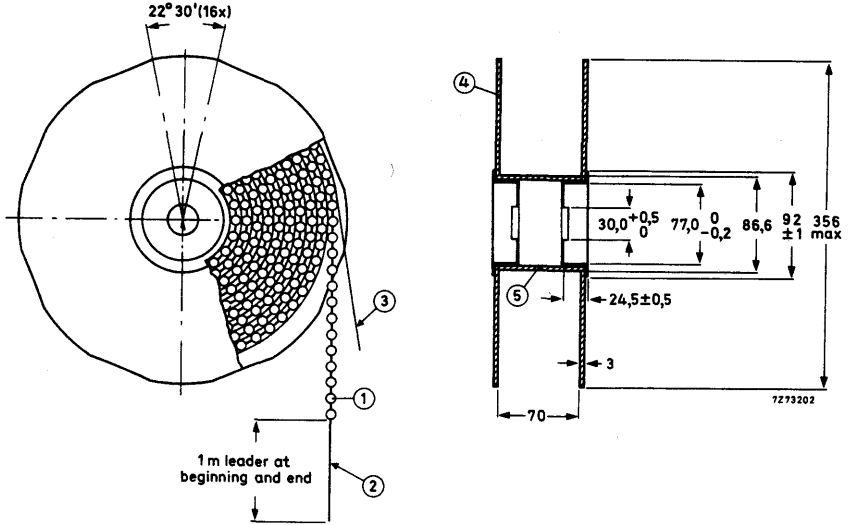

Fig. 2 Reel dimensions (mm).

- (1) Diode
- (2) Bandolier
- (3) Paper
- (4) Flange
- (5) Cylinder

Outline		quantity per reel
SOD-2	DO-14	5000
SOD-7	DO-7	7000
SOD-17	DO-35	9000
SOD-18	—	1250
SOD-22	—	7000
SOD-27	DO-35	9000
SOD-34	—	5000
SOD-40	DO-15	5000
SOD-51	—	5000
SOD-56	—	4000
SOD-57	—	4500
SOD-61	—	8000
SOD-64	—	4000
SOD-66	DO-41	7000
SOD-68	DO-34	9000

RULES FOR MOUNTING AND SOLDERING

Introduction

Excessive forces or temperatures applied to a diode may cause serious damage to the diode. To avoid damage when soldering and mounting the following rules should be followed.

General

Perpendicular forces on the body of the diode must be avoided.

Avoid sudden forces on the leads or body. These forces often are much higher than allowed.

High acceleration forces as a result of any shock (dropping on a hard surface for instance) must be prevented.

Bending

During bending the leads must be supported between body or stud and bending point.

Axial forces on the body during the bending process must not exceed 20 N.

Bending the leads through 90° is allowed at any distance from the body when it is possible to support the leads during bending without contacting the envelope

Bending close to the body or stud without supporting the leads only is allowed if the bend radius is greater than 0,5 mm; in practice this limit will be met by hand bending without applying high pulling or pressing forces.

Twisting

Twisting the leads is allowed at any distance from the body or stud if the lead is properly clamped between body or stud and twisting point.

Without clamping, twisting the leads is only allowed at a distance of greater than 3 mm from the body; the torque angle must not exceed 30°, the applied force not higher than 15 mNm.

Straightening

Straightening the leads is allowed if the applied pulling force in the axial direction does not exceed 20 N and the total duration is not longer than 5 seconds.

Soldering

Avoid any force on the body or leads during or just after soldering.

Do not correct the position of an already soldered device by pushing, pulling or twisting the body.

Do not solder a diode upright with one end of the body directly on the surface of the printed-circuit board, there should be at least 0,5 mm between body end and print surface.

When the device is to be mounted with straight or short-cropped leads, solder the leads individually. Bent leads may be soldered simultaneously.

The diode can be mounted flat on the printed-circuit board when the body temperature of the diode will not exceed:

- The maximum allowed storage temperature, where this is higher than 175 °C;
- 115 °C for more than 2 minutes (with an absolute peak temperature for the junction of 160 °C), where the maximum storage temperature is less than 175 °C.

MOUNTING AND SOLDERING

Any contact between diode body and hot spots on the printed-circuit board (such as copper layers) must be avoided.

Prevent fast cooling after soldering.

Minimum distance soldering point to seal and maximum allowable soldering time for several envelopes.

			Hand soldering iron mounted otherwise than on printed-circuit board (max. solder temp.: 300 °C)		Hand soldering iron, dip or wave soldering, mounted on printed-circuit board (max. solder temp.: 300 °C)	
			time s	distance mm	time s	distance mm
SOD-2	DO-14	plastic	5	5,0	5	5,0
SOD-7	DO-7	glass	3	5,0	5	5,0 *
SOD-17	DO-35	glass	3	1,5	5	1,5
SOD-18	—	plastic	3	5,0	5	5,0
SOD-22	—	plastic	3	5,0	5	5,0
SOD-23	—	plastic	3	0,5	5	0,5
SOD-27	DO-35	glass	3	1,5	5	1,5
SOD-34	—	plastic	3	2,0	5	2,0
SOD-40	DO-15	plastic	3	5,0	5	5,0
SOD-51	—	glass	3	3,0	5	3,0
SOD-52	—	plastic	3	0,5	5	0,5
SOD-56	—	plastic	3	2,0	5	2,0
SOD-57	—	glass	3	1,5	5	1,5
SOD-61	—	glass	3	2,0	5	2,0
SOD-64	—	glass	3	1,5	5	1,5
SOD-66	DO-41	glass	3	3,0	5	3,0
SOD-68	DO-34	glass	3	1,5	5	1,5
TO-18	—	metal	3	0,5	5	0,5
TO-92	—	plastic	3	2,5	5	2,5

* 2 mm permissible from anode (upright mounting) if bath temperature ≤ 260 °C.

SILICON WHISKERLESS DIODES

B





10 V, 30 V and 50 V GENERAL PURPOSE DIODES

Silicon planar epitaxial diodes in DO-35 envelopes intended for general purpose applications.

They have reverse voltages up to 10 V for BA316, 30 V for BA317 and 50 V for BA318.

QUICK REFERENCE DATA						
			BA316	BA317	BA318	
Continuous reverse voltage	V_R	max.	10	30	50	V
Repetitive peak forward current	I_{FRM}	max.	225			mA
Storage temperature	T_{stg}		-65 to +200			°C
Junction temperature	T_j	max.	200			°C
Thermal resistance from junction to ambient	$R_{th\ j-a}$	=	0,60			°C/mW
Forward voltage at $I_F = 1,0$ mA	V_F	<	700			mV
$I_F = 10$ mA	V_F	<	850			mV
$I_F = 100$ mA	V_F	<	1100			mV
Diode capacitance at $V_R = 0$; $f = 1$ MHz	C_d	<	2			pF
Reverse recovery time when switched from $I_F = 10$ mA to $I_R = 60$ mA; $R_L = 100 \Omega$; measured at $I_R = 1$ mA	t_{rr}	<	4			ns

MECHANICAL DATA

Dimensions in mm

DO-35

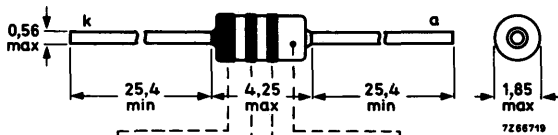

BA316:	orange	brown	blue	natural
BA317:	orange	brown	violet	natural
BA318:	orange (cathode)	brown	grey	natural

The diodes may be either type-branded or colour-coded.



RATINGS Limiting values in accordance with the Absolute Maximum System (IEC134)

Voltage

		BA316	BA317	BA318
Continuous reverse voltage	V_R max.	10	30	50 V

Currents

Average rectified forward current (averaged over any 20 ms period)	$I_{F(AV)}$ max.	100		mA 1)
Forward current (d.c.)	I_F max.	100		mA
Repetitive peak forward current	I_{FRM} max.	225		mA
Non-repetitive peak forward current $t = 1 \mu s$	I_{FSM} max.	2000		mA
$t = 1 s$	I_{FSM} max.	500		mA

Temperatures

Storage temperature	T_{stg}	-65 to +200		$^{\circ}C$
Junction temperature	T_j max.	200		$^{\circ}C$

THERMAL RESISTANCE

From junction to ambient in free air	R_{thj-a} =	0,60		$^{\circ}C/mW$
--------------------------------------	---------------	------	--	----------------

CHARACTERISTICS

$T_j = 25 \text{ }^{\circ}C$

Forward voltage

$I_F = 1,0 \text{ mA}$	V_F <	700		mV
$I_F = 10 \text{ mA}$	V_F <	850		mV
$I_F = 100 \text{ mA}$	V_F <	1100		mV

Reverse current

		BA316	BA317	BA318
$V_R = 10 \text{ V}$	I_R <	200	50	- nA
$V_R = 30 \text{ V}$	I_R <	-	200	50 nA
$V_R = 50 \text{ V}$	I_R <	-	-	200 nA

Diode capacitance

$V_R = 0; f = 1 \text{ MHz}$	C_d <	2		pF
------------------------------	---------	---	--	----

1) For sinusoidal operation see page 6. For pulse operation see pages 4 and 5.

CHARACTERISTICS (continued)

$T_j = 25\text{ }^\circ\text{C}$

Reverse recovery time when switched from

$I_F = 10\text{ mA}$ to $I_R = 60\text{ mA}$; $R_L = 100\text{ }\Omega$;

Measured at $I_R = 1\text{ mA}$

$t_{rr} < 4\text{ ns}$

Test circuit and waveforms:

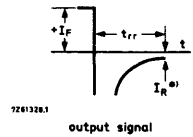
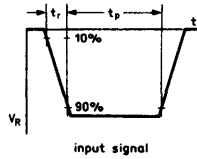
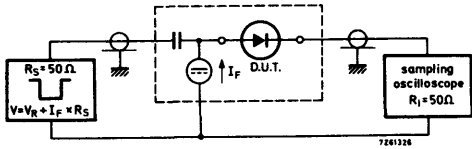

Input signal : Rise time of the reverse pulse

$t_r = 0,6\text{ ns}$

$I_R = 1\text{ mA}$

Reverse pulse duration

$t_p = 100\text{ ns}$

Duty factor

$\delta = 0,05$

Oscilloscope: Rise time

$t_r = 0,35\text{ ns}$

Circuit capacitance $C \leq 1\text{ pF}$ ($C = \text{oscilloscope input capacitance} + \text{parasitic capacitance}$)

**BA316
BA317
BA318**

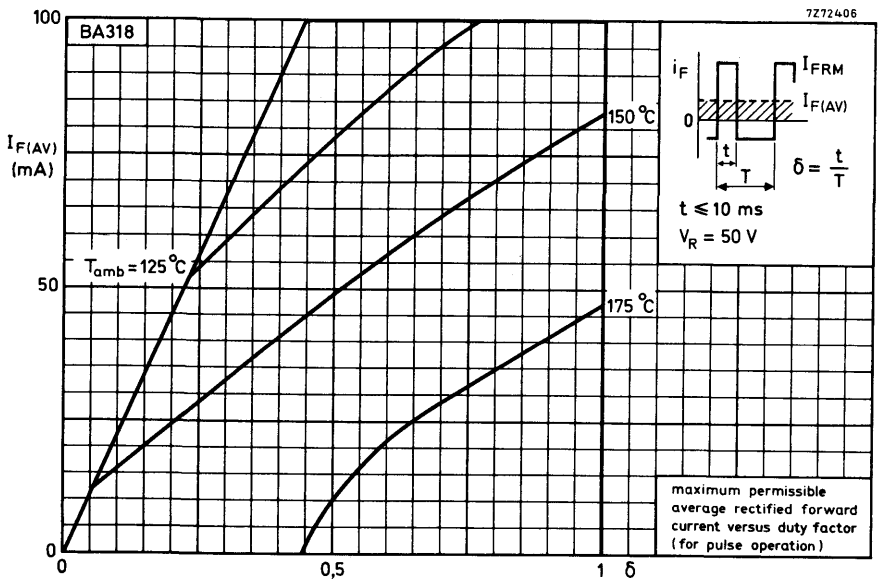
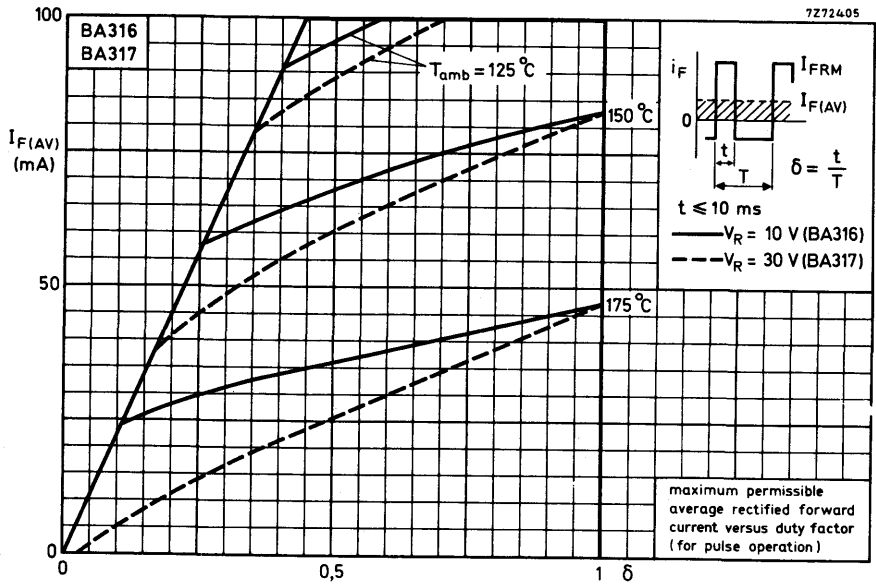

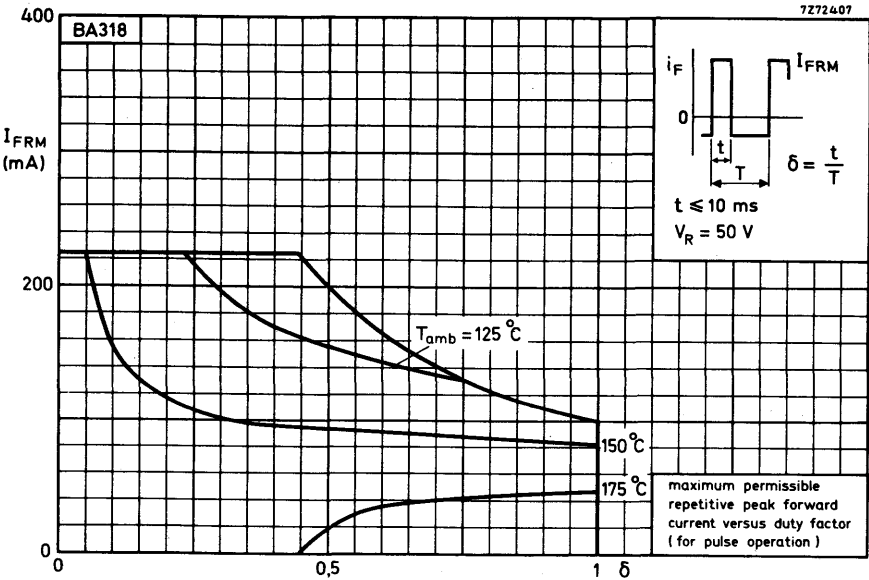
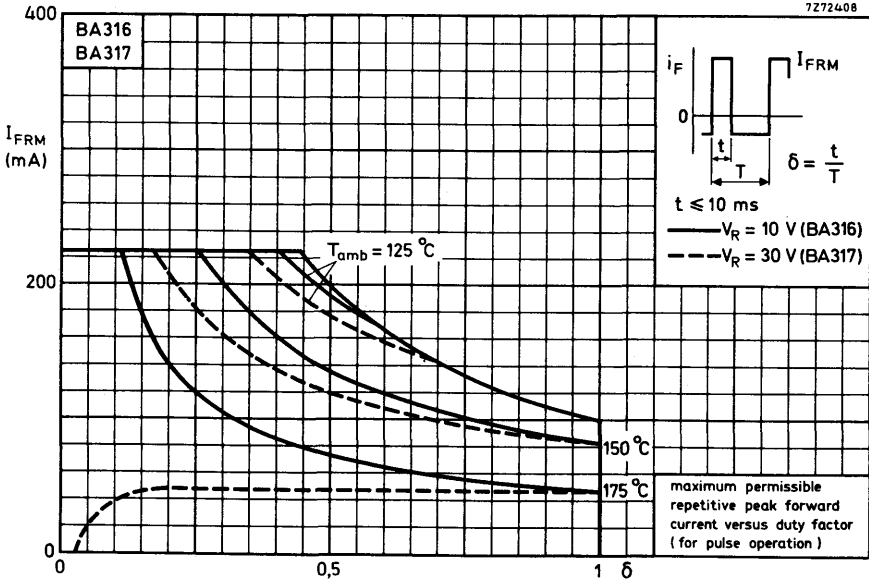

**BA316
BA317
BA318**

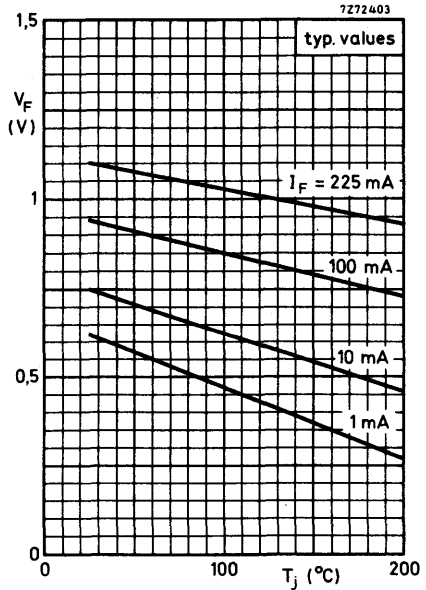
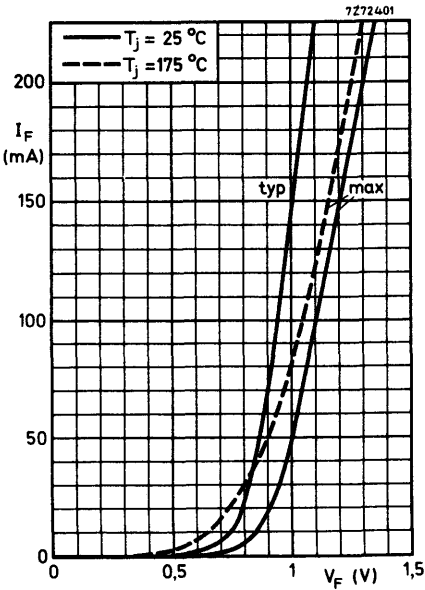
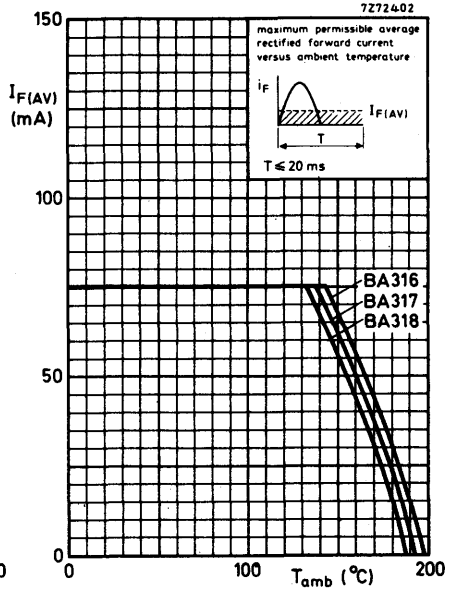
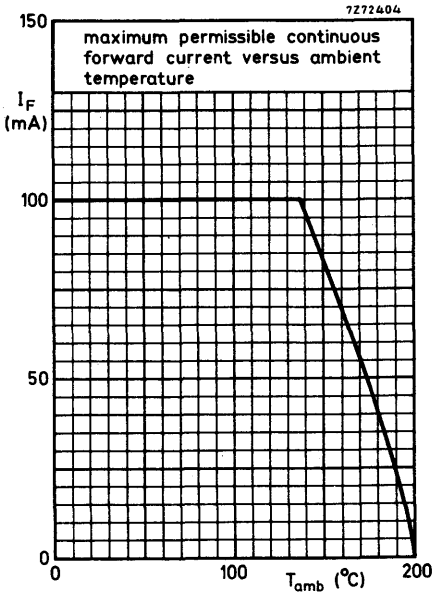

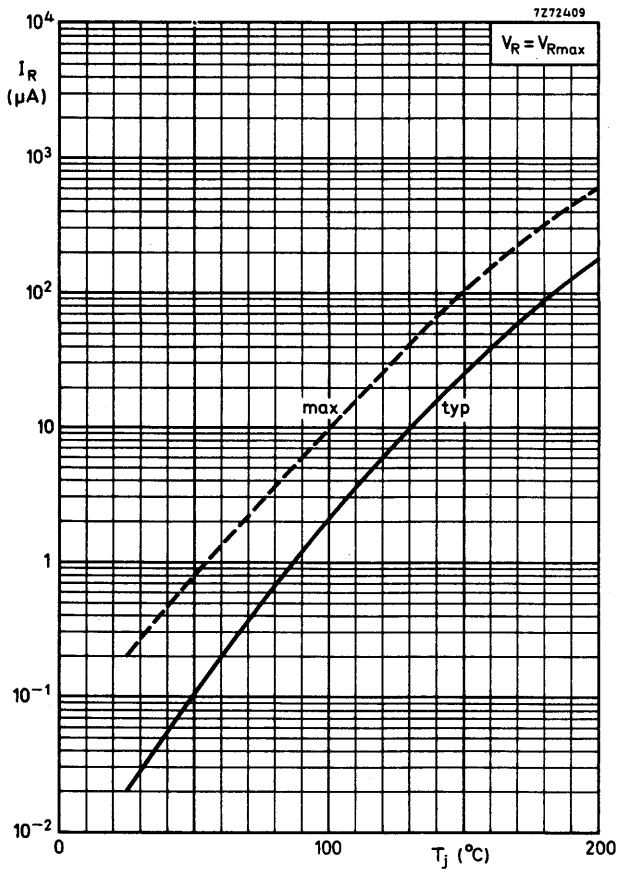



SILICON GLASS PASSIVATED AVALANCHE DIODE

Diode in a DO-35 envelope. It is primarily intended for general purpose applications, e.g. scan and flyback rectifiers, protection diodes etc. in television circuits. An advantage of this diode is its capability of absorbing reverse transient energy.

QUICK REFERENCE DATA

Working reverse voltage	V_{RW}	max.	300 V
Average rectified forward current	$I_{F(AV)}$	max.	300 mA
Non-repetitive peak forward current	I_{FSM}	max.	4 A
Repetitive peak reverse power dissipation	P_{RRM}	max.	75 W
Reverse recovery time	t_{rr}	<	1 μ s

MECHANICAL DATA

Dimensions in mm

Fig. 1 SOD-27 (DO-35).

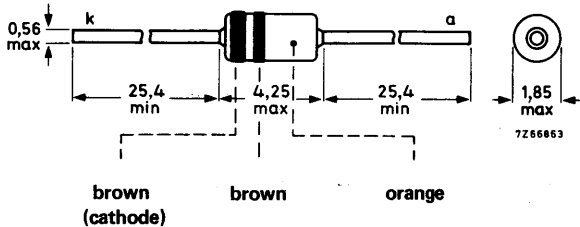

Diodes may be either type-branded or colour-coded.

RATINGS

Limiting values in accordance with the Absolute Maximum System (IEC 134)

Working reverse voltage	V_{RW}	max.	300 V
Continuous reverse voltage (see Fig. 2)	V_R	max.	300 V
Forward current (d.c.)	I_F	max.	350 mA
Average forward current (averaged over any 20 ms period)	$I_{F(AV)}$	max.	300 mA
Repetitive peak forward current $t = 10$ ms; $f = 50$ Hz $\delta = 0,1$; $f = 15$ kHz	I_{FRM}	max.	900 mA
	I_{FRM}	max.	2 A
Non-repetitive peak forward current ($t = 10$ ms; half sine-wave) $T_j = 150$ °C prior to surge ($t = 10$ μ s; square wave) $T_j = 150$ °C prior to surge	I_{FSM}	max.	4 A
	I_{FSM}	max.	30 A
Repetitive peak reverse current $t = 10$ μ s (square wave; $f = 50$ Hz) $T_{amb} = 25$ °C	I_{RRM}	max.	150 mA
Repetitive peak reverse power dissipation $t = 10$ μ s (square wave; $f = 50$ Hz) $T_{amb} = 25$ °C	P_{RRM}	max.	75 W
Storage temperature	T_{stg}	-65 to +150	°C
Junction temperature	T_j	max.	150 °C

THERMAL RESISTANCE

From junction to ambient in free air
mounted on printed board at 8 mm lead length

$$R_{th\ j-a} = 0,34 \text{ } ^\circ\text{C/mW}$$

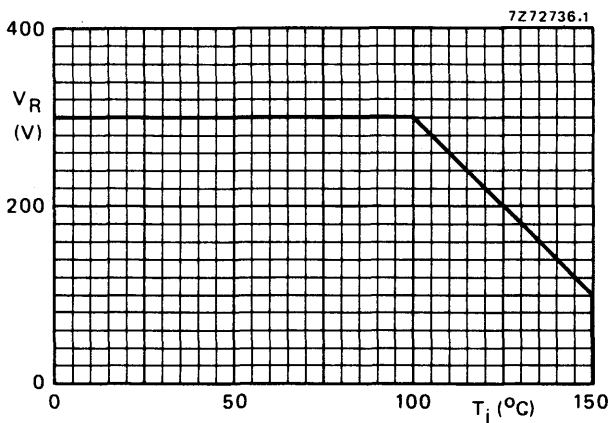

Fig. 2 Maximum permissible continuous reverse voltage versus junction temperature.

CHARACTERISTICS

$T_j = 25\text{ }^\circ\text{C}$ unless otherwise specified

Forward voltage

$I_F = 300\text{ mA}$

$V_F < 1,1\text{ V}$

$I_F = 900\text{ mA}$

$V_F < 1,3\text{ V}$

Reverse avalanche breakdown voltage

$I_R = 100\text{ }\mu\text{A}$

$V_{(BR)R} > 300\text{ V}$

Reverse current

$V_R = 300\text{ V}; T_j = 100\text{ }^\circ\text{C}$

$I_R < 20\text{ }\mu\text{A}$

Diode capacitance at $f = 1\text{ MHz}$

$V_R = 0$

C_d typ. 10 pF

$V_R = 50\text{ V}$

C_d typ. $1,5\text{ pF}$

Reverse recovery when switched from

$I_{FM} = 400\text{ mA}$ to $V_R = 30\text{ V}$; with $-dI_F/dt = 400\text{ mA}/\mu\text{s}$

Q_s typ. 70 nC

Recovery charge

Recovery time

$t_{rr} < 1\text{ }\mu\text{s}$

Maximum slope of reverse recovery current when switched from

$I_{FM} = 400\text{ mA}$ to $V_R = 30\text{ V}$; with $-dI_F/dt = 400\text{ mA}/\mu\text{s}$

$|dI_R/dt|$ typ. $2,0\text{ A}/\mu\text{s}$

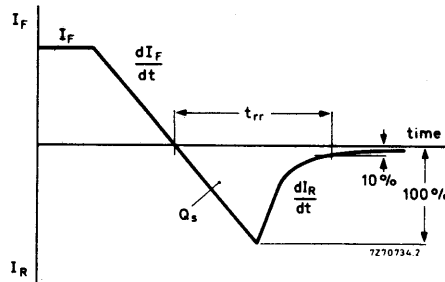

Fig. 3 Definitions of Q_s , t_{rr} and dI_R/dt .

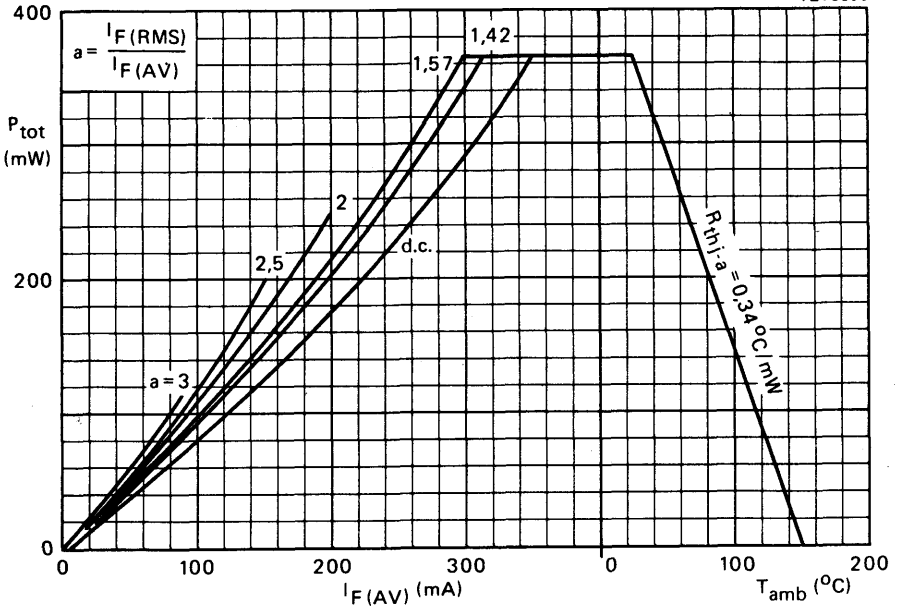

Fig. 4.

From the left-hand graph the total power dissipation can be found as a function of the average output current.

The parameter $a = \frac{I_F(RMS) \text{ per diode}}{I_F(AV) \text{ per diode}}$ depends on $n\omega R_L C_L$ and $\frac{R_t + r_{diff}}{nR_L}$ and can be found from existing graphs.

Once the power dissipation is known, the maximum permissible ambient temperature follows from the right-hand graph.

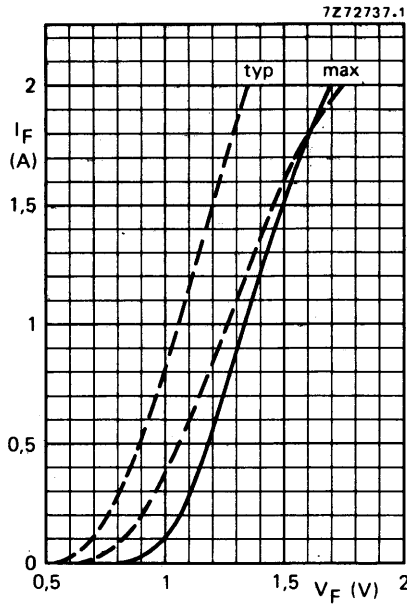

Fig. 5 — $T_j = 25\text{ }^\circ\text{C}$; --- $T_j = 150\text{ }^\circ\text{C}$.

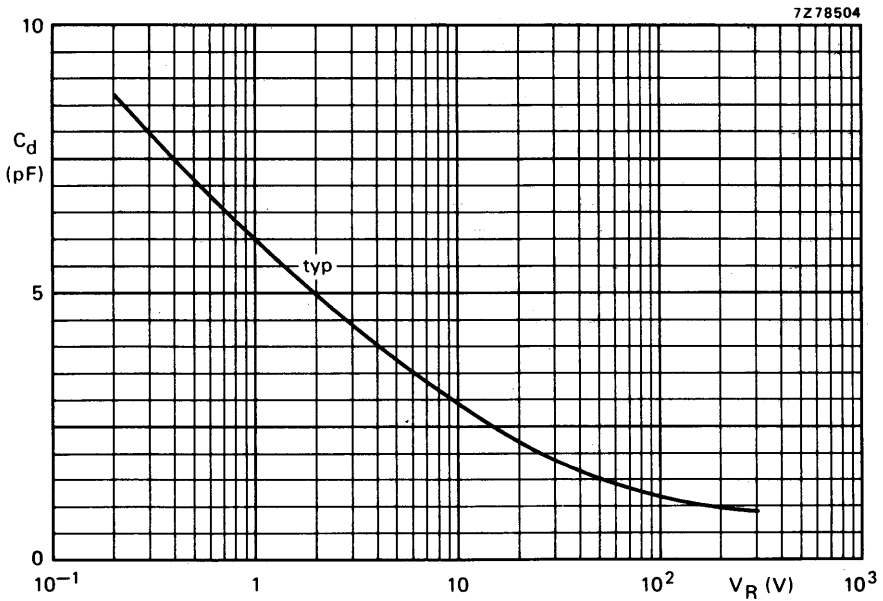

Fig. 6 $f = 1\text{ MHz}$; $T_j = 25\text{ }^\circ\text{C}$.



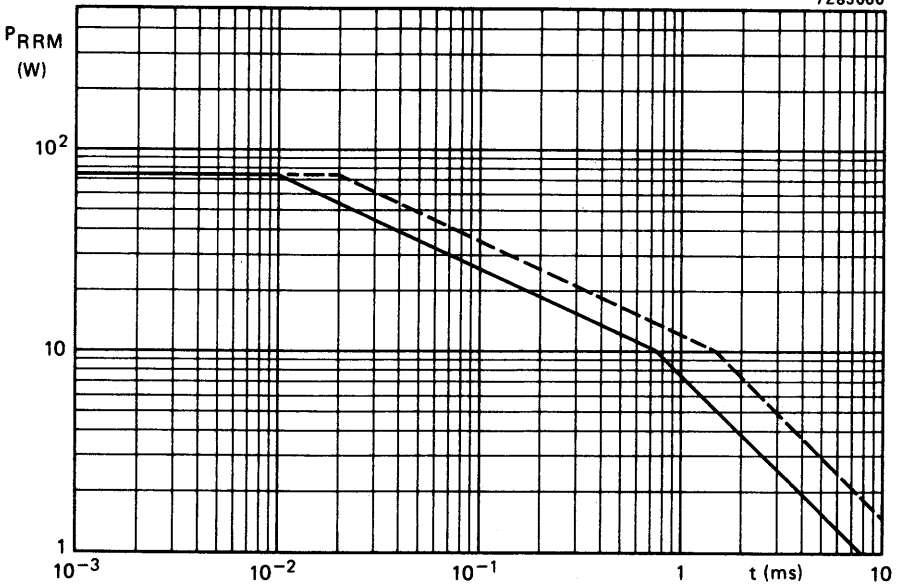

Fig. 7 Maximum permissible repetitive peak reverse power as a function of pulse duration. $T \geq 20$ ms; $T_j = 25$ °C.

- rectangular waveform, $\delta \leq 0,01$.
- - - - - triangular waveform, $\delta \leq 0,02$.

ULTRA-HIGH-SPEED DIODE

Silicon planar epitaxial, ultra-high-speed, high-conductance diode in a DO-35 envelope. The BAV10 is primarily intended for core gating in very fast memories.

QUICK REFERENCE DATA			
Continuous reverse voltage	V_R	max.	60 V
Repetitive peak reverse voltage	V_{RRM}	max.	60 V
Repetitive peak forward current	I_{FRM}	max.	600 mA
Junction temperature	T_j	max.	200 °C
Forward voltage at $I_F = 200$ mA	V_F	<	1,0 V
Reverse recovery time when switched from $I_F = 400$ mA to $I_R = 400$ mA; $R_L = 100 \Omega$; measured at $I_R = 40$ mA	t_{rr}	<	6 ns
Recovery charge when switched from $I_F = 10$ mA to $V_R = 5$ V; $R_L = 500 \Omega$	Q_s	<	50 pC

MECHANICAL DATA

Dimensions in mm

DO-35

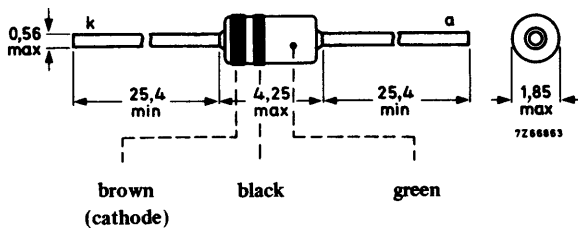

The diodes may be either type-branded or colour-coded.



RATINGS Limiting values in accordance with the Absolute Maximum System (IEC 134)

Voltages

Continuous reverse voltage	V_R	max.	60 V
Repetitive peak reverse voltage	V_{RRM}	max.	60 V ¹⁾

Currents

Average rectified forward current	$I_{F(AV)}$	max.	300 mA ²⁾
Forward current (d. c.)	I_F	max.	300 mA
Repetitive peak forward current	I_{FRM}	max.	600 mA
Non-repetitive peak forward current $t = 1 \mu s$	I_{FSM}	max.	4000 mA
$t = 1 s$	I_{FSM}	max.	1000 mA

Temperatures

Storage temperature	T_{stg}		-65 to +200 °C
Junction temperature	T_j	max.	200 °C

THERMAL RESISTANCE

From junction to ambient in free air
at maximum lead length

$$R_{th j-a} = 0,5 \text{ } ^\circ\text{C/mW}$$

CHARACTERISTICS

$T_j = 25 \text{ } ^\circ\text{C}$ unless otherwise specified

Forward voltage

$I_F = 10 \text{ mA}$	V_F	<	0,75 V
$I_F = 200 \text{ mA}$	V_F	<	1,00 V
$I_F = 200 \text{ mA}; T_j = 100 \text{ } ^\circ\text{C}$	V_F	<	0,95 V
$I_F = 500 \text{ mA}$	V_F	<	1,25 V

Reverse current

$V_R = 60 \text{ V}$	I_R	<	100 nA
$V_R = 60 \text{ V}; T_j = 150 \text{ } ^\circ\text{C}$	I_R	<	100 μA

Diode capacitance

$V_R = 0; f = 1 \text{ MHz}$	C_d	<	2,5 pF
------------------------------	-------	---	--------

1) Measured at zero life time at $I_R = 10 \mu\text{A}; V_R = 75 \text{ V}$.

2) For sinusoidal operation see page 6. For pulse operation see page 5.

CHARACTERISTICS (continued)

$T_j = 25\text{ }^\circ\text{C}$

Forward recovery voltage when switched to

$I_F = 400\text{ mA}; t_{r1} = 30\text{ ns}$

$V_{fr} < 2,0\text{ V}$

$I_F = 400\text{ mA}; t_{r2} = 100\text{ ns}$

$V_{fr} < 1,5\text{ V}$

Test circuit and waveforms:

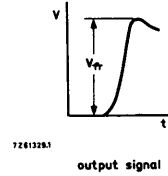
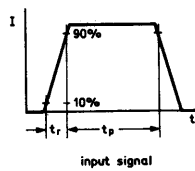
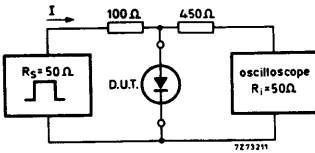

- Input signal : 1st rise time of the forward pulse $t_{r1} = 30\text{ ns}$
- 2nd rise time of the forward pulse $t_{r2} = 100\text{ ns}$
- Forward current pulse duration $t_p = 300\text{ ns}$
- Duty factor $\delta = 0,01$

- Oscilloscope: Rise time $t_R = 0,35\text{ ns}$
- Input capacitance $C_i \leq 1\text{ pF}$

Circuit capacitance $C \leq 20\text{ pF}$ ($C = C_i + \text{parasitic capacitance}$)

Reverse recovery time when switched from

$I_F = 400\text{ mA}$ to $I_R = 400\text{ mA}; R_L = 100\text{ }\Omega$;
measured at $I_R = 40\text{ mA}$

$t_{rr} < 6\text{ ns}$

Test circuit and waveforms:

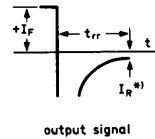
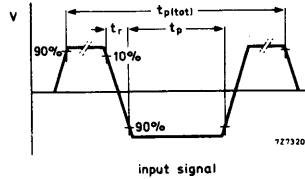
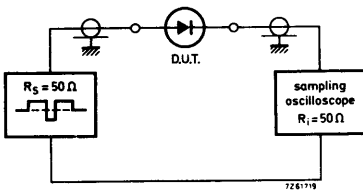

- Input signal : Total pulse duration $t_p(\text{tot}) = 0,2\text{ }\mu\text{s}$
- Duty factor $\delta = 0,0025$
- Rise time of the reverse pulse $t_R = 0,6\text{ ns}$
- Reverse pulse duration $t_p = 30\text{ ns}$

*) $I_R = 40\text{ mA}$

- Oscilloscope: Rise time $t_R = 0,35\text{ ns}$

Circuit capacitance $C \leq 1\text{ pF}$ ($C = \text{oscilloscope input capacitance} + \text{parasitic capacitance}$)

CHARACTERISTICS (continued)

$T_j = 25\text{ }^\circ\text{C}$

Recovery charge when switched from

$I_F = 10\text{ mA}$ to $V_R = 5\text{ V}$; $R_L = 500\ \Omega$

$Q_S < 50\text{ pC}$

Test circuit and waveform:

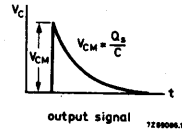
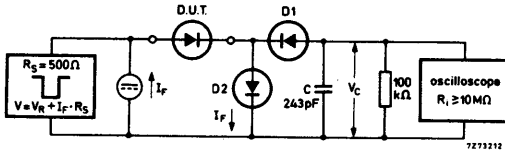

D1 = BAW62

D2 = diode with minority carrier life time at 10 mA: $< 200\text{ ps}$

Input signal : Rise time of the reverse pulse $t_r = 2\text{ ns}$

Reverse pulse duration $t_p = 400\text{ ns}$

Duty factor $\delta = 0,02$

Circuit capacitance $C \leq 7\text{ pF}$ ($C = \text{oscilloscope input capacitance} + \text{parasitic capacitance}$)

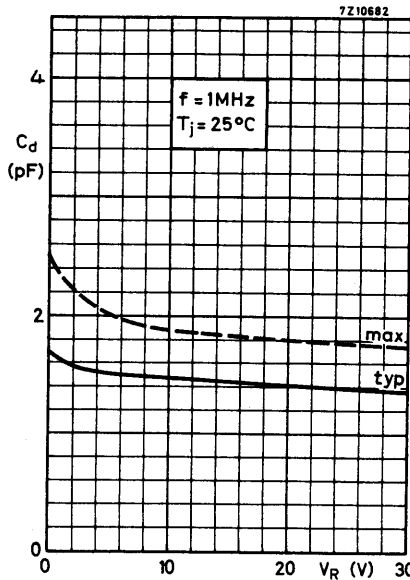

7272421

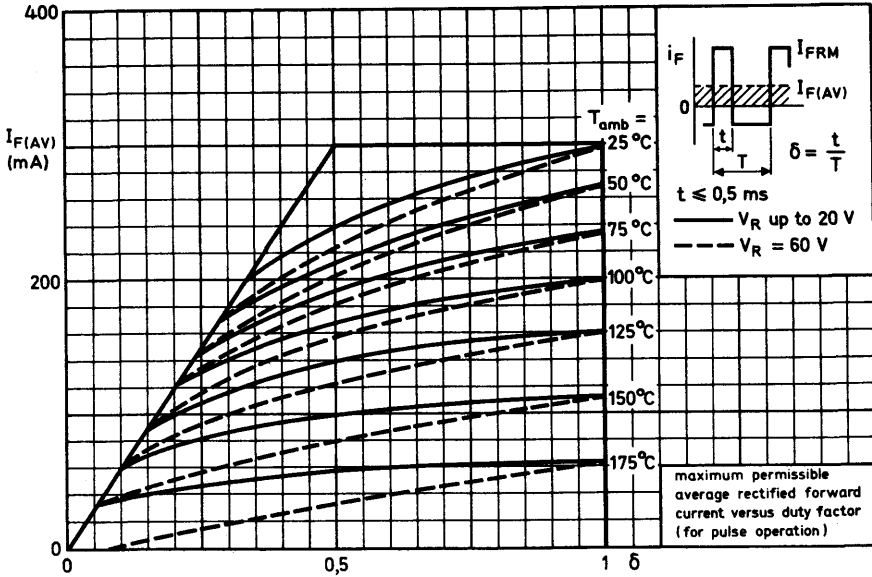

7272422

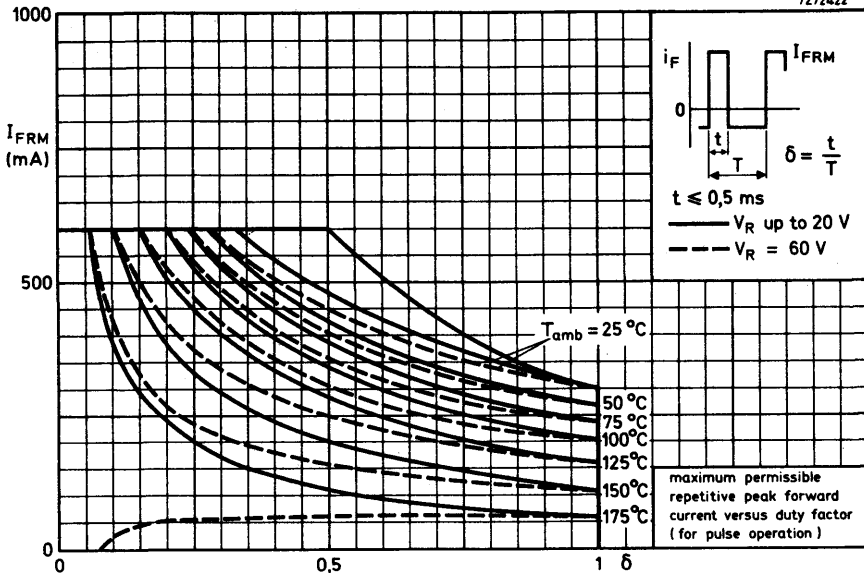

7210678.1

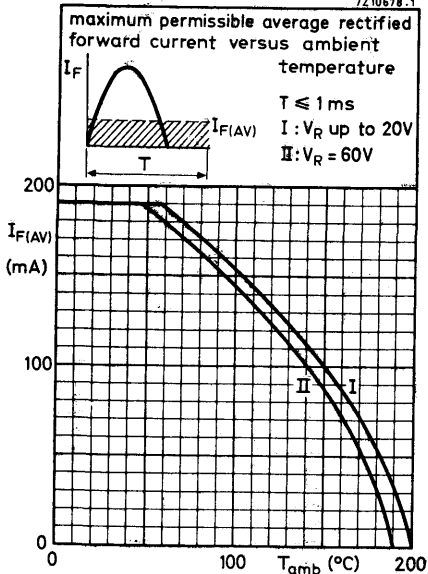

7210677.1

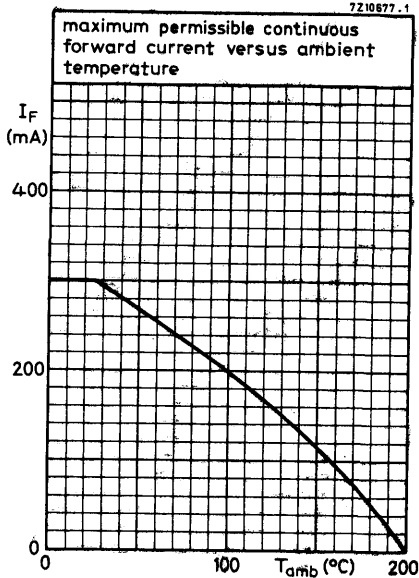

7210683.1

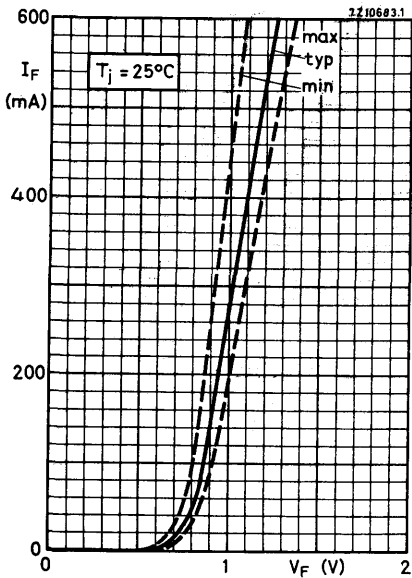

7210682

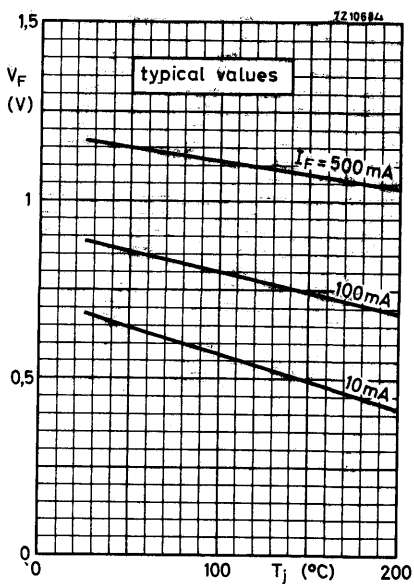

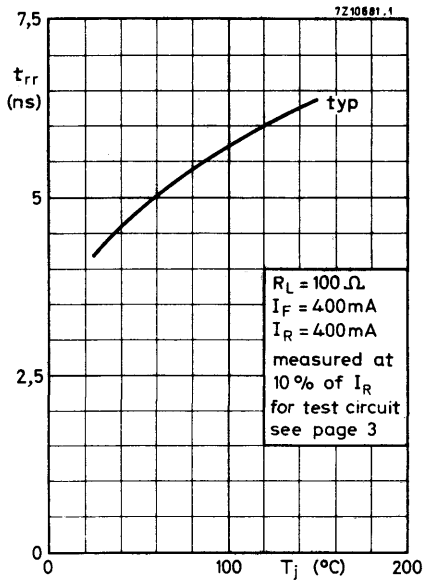
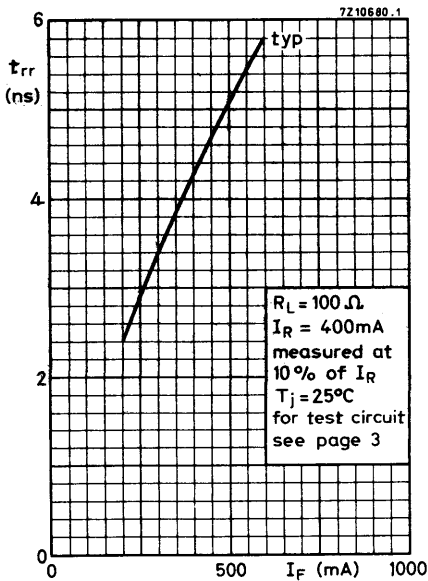
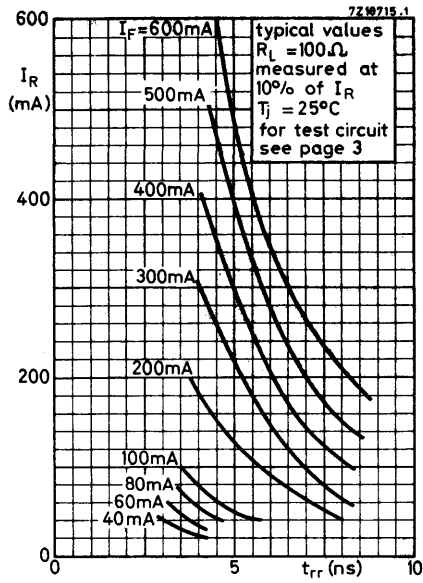
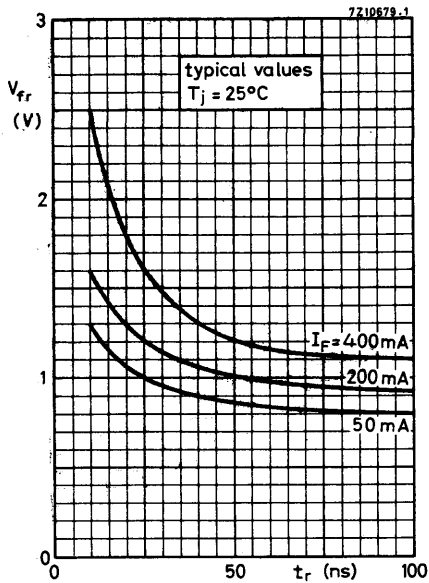

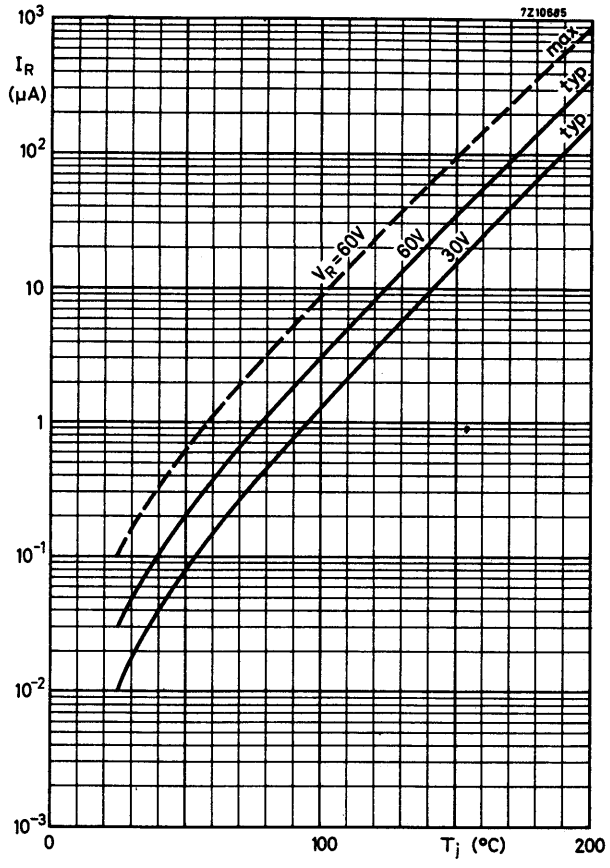

GENERAL PURPOSE DIODES



Silicon planar epitaxial diodes in DO-35 envelopes; intended for switching and general purposes in industrial equipment e.g. oscilloscopes, digital voltmeters and video output stages in colour television.

QUICK REFERENCE DATA

			BAV18	BAV19	BAV20	BAV21	
Continuous reverse voltage	V_R	max.	50	100	150	200	V
Forward current (d.c.)	I_F	max.		250			mA
Junction temperature	T_j	max.		175			°C
Thermal resistance from junction to ambient	$R_{th j-a}$	=		0,375			K/mW
Forward voltage at $I_F = 100$ mA	V_F	<		1,0			V
Reverse current at $V_R = V_{Rmax}$	I_R	<		100			nA
Diode capacitance at $V_R = 0$; $f = 1$ MHz	C_d	typ. <		1,5			pF
Reverse recovery time when switched from $I_F = 30$ mA to $I_R = 30$ mA; $R_L = 100 \Omega$; measured at $I_R = 3$ mA	t_{rr}	<		50			ns

MECHANICAL DATA

Dimensions in mm

Fig. 1 SOD-27 (DO-35).

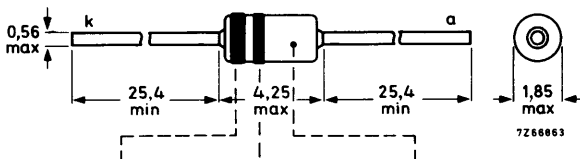

BAV18:	brown	grey	green
BAV19:	brown	white	green
BAV20:	red	black	green
BAV21:	red	brown	green

(cathode)

Diodes may be either type-branded or colour coded.

Products approved to CECC 50 001-022, available on request.



RATINGS Limiting values in accordance with the Absolute Maximum System (IEC 134)

Voltages

			BAV18	BAV19	BAV20	BAV21	
Continuous reverse voltage	V_R	max.	50	100	150	200	V
Repetitive peak reverse voltage	V_{RRM}	max.	60	120	200	250	V

Currents

Average rectified forward current		$I_F(AV)$	max.	250	mA	1)
Forward current (d. c.)		I_F	max.	250	mA	
Repetitive peak forward current		I_{FRM}	max.	625	mA	
Non-repetitive peak forward current						
$t < 1 \text{ s}$; $T_j = 25 \text{ }^\circ\text{C}$		I_{FSM}	max.	1	A	
$t = 1 \text{ } \mu\text{s}$; $T_j = 25 \text{ }^\circ\text{C}$		I_{FSM}	max.	5	A	

Power dissipation

Total power dissipation up to $T_{amb} = 25 \text{ }^\circ\text{C}$		P_{tot}	max.	400	mW
---	--	-----------	------	-----	----

Temperatures

Storage temperature		T_{stg}	-65 to +175	$^\circ\text{C}$
Junction temperature		T_j	max. 175	$^\circ\text{C}$

THERMAL RESISTANCE

From junction to ambient in free air		$R_{th \text{ j-a}}$	=	0,375	$^\circ\text{C/mW}$
--------------------------------------	--	----------------------	---	-------	---------------------

1) For sinusoidal operation see page 6. For pulse operation see pages 4 and 5.

CHARACTERISTICS

$T_j = 25\text{ }^\circ\text{C}$ unless otherwise specified

Forward voltage

$$I_F = 100\text{ mA}$$

$$V_F < 1,0\text{ V}$$

$$I_F = 200\text{ mA}$$

$$V_F < 1,25\text{ V}$$

Reverse breakdown voltage

$$I_R = 100\text{ }\mu\text{A}$$

	BAV18	BAV19	BAV20	BAV21	
$V_{(BR)R}$	> 60	120	200	250	V ¹⁾

Reverse current

$$V_R = V_{Rmax}$$

$$I_R < 100\text{ nA}$$

$$V_R = V_{Rmax}; T_j = 150\text{ }^\circ\text{C}$$

$$I_R < 100\text{ }\mu\text{A}$$

Differential resistance

$$I_F = 10\text{ mA}$$

$$r_{diff} \text{ typ. } 5\text{ }\Omega$$

Diode capacitance

$$V_R = 0; f = 1\text{ MHz}$$

$$C_d \text{ typ. } 1,5\text{ pF}$$

$$< 5,0\text{ pF}$$

Reverse recovery time when switched from

$$I_F = 30\text{ mA to } I_R = 30\text{ mA}; R_L = 100\text{ }\Omega;$$

$$\text{measured at } I_R = 3\text{ mA}$$

$$t_{rr} < 50\text{ ns}$$

Test circuit and waveforms:

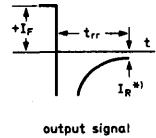
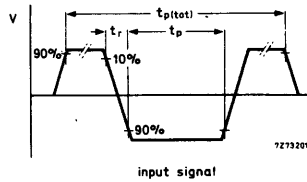
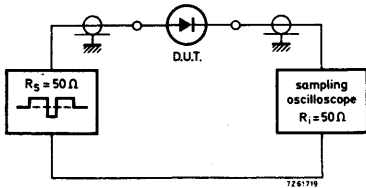

Input signal : Total pulse duration

$$t_{p(tot)} = 2\text{ }\mu\text{s}$$

Duty factor

$$\delta = 0,0025$$

Rise time of the reverse pulse

$$t_r = 0,6\text{ ns}$$

Reverse pulse duration

$$t_p = 100\text{ ns}$$

Oscilloscope: Rise time

$$t_r = 0,35\text{ ns}$$

Circuit capacitance $C \leq 1\text{ pF}$ ($C = \text{oscilloscope input capacitance} + \text{parasitic capacitance}$)

¹⁾ At zero life time, measured under pulse conditions to avoid excessive dissipation and voltage limited at 275 V.

BAV18 to 21

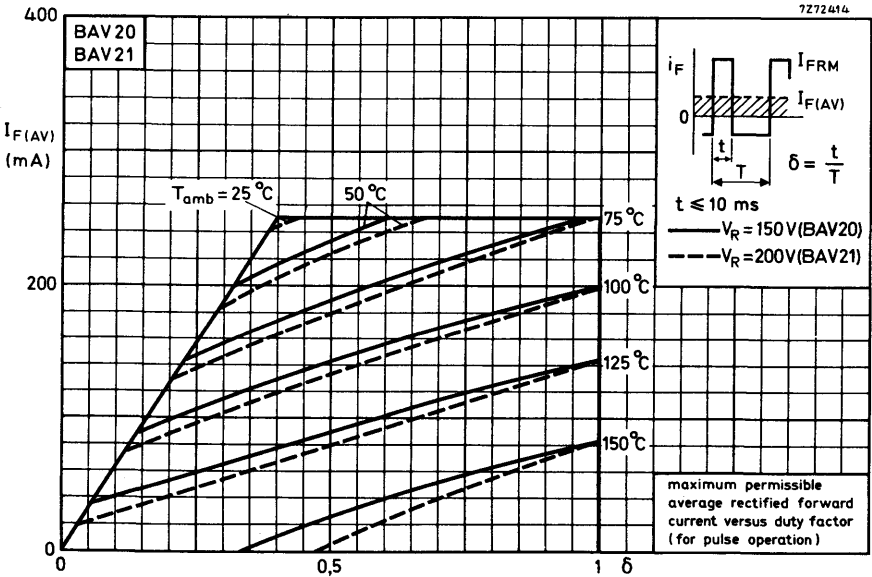
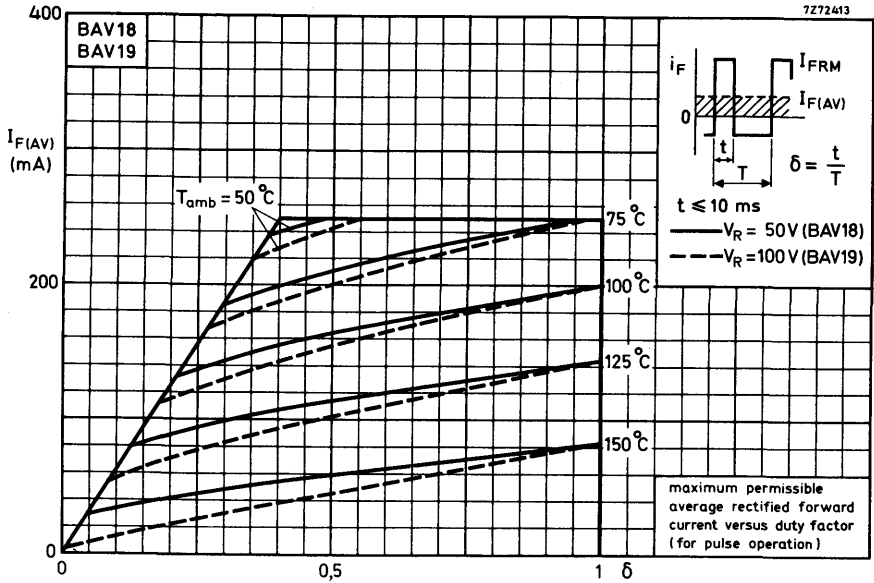

7272411

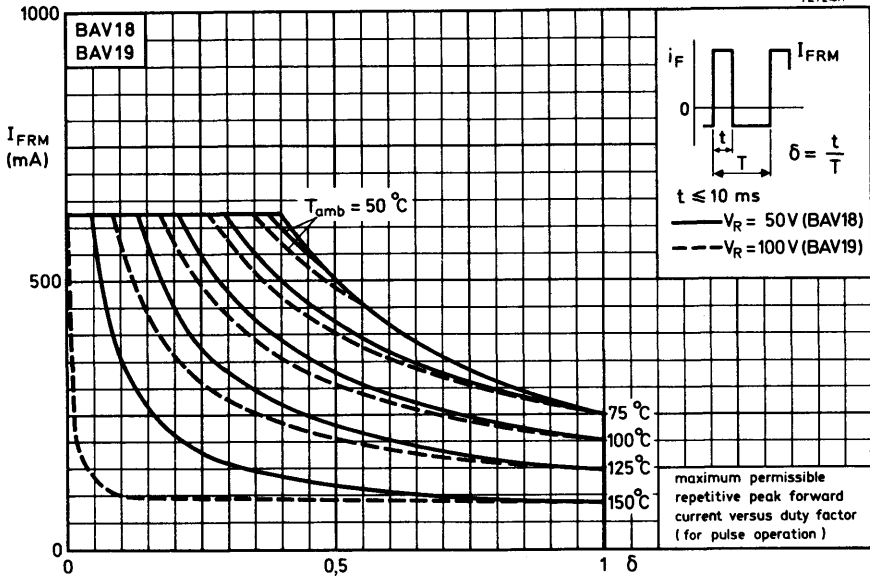

7272412

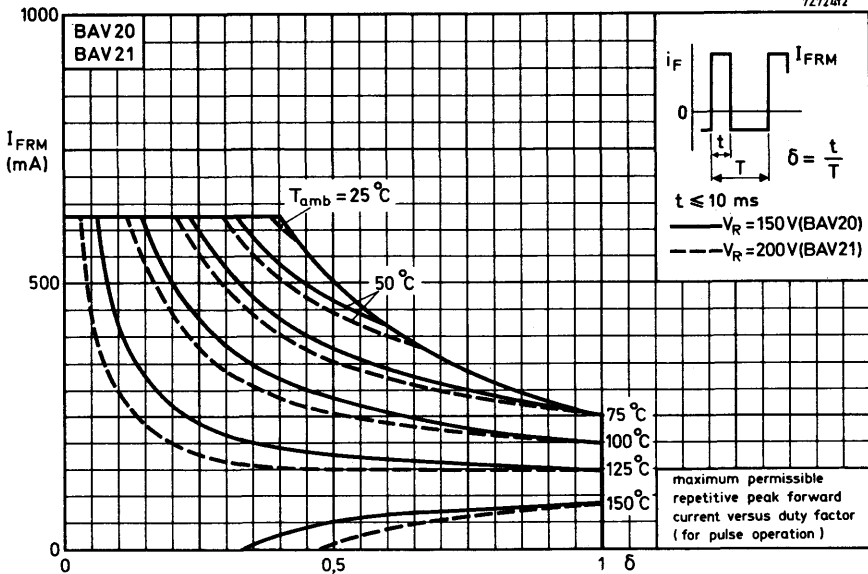

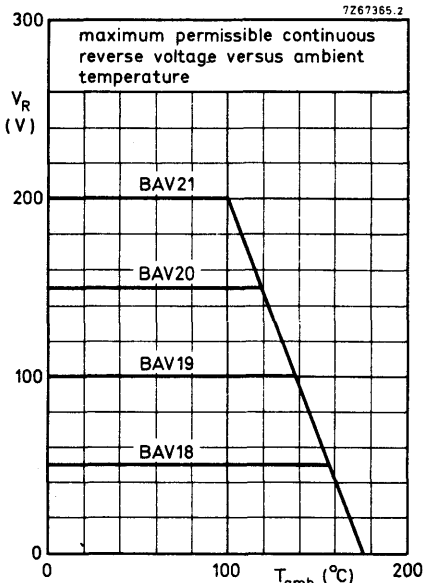
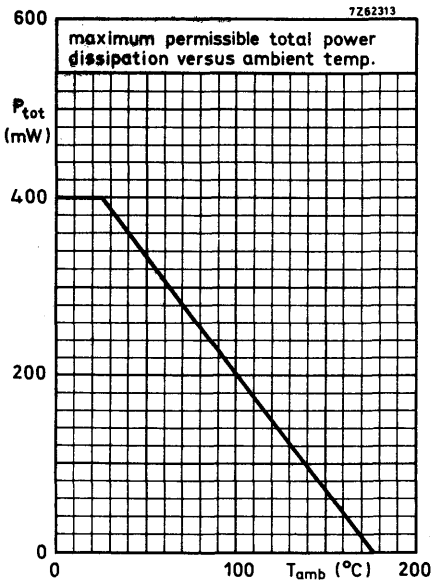
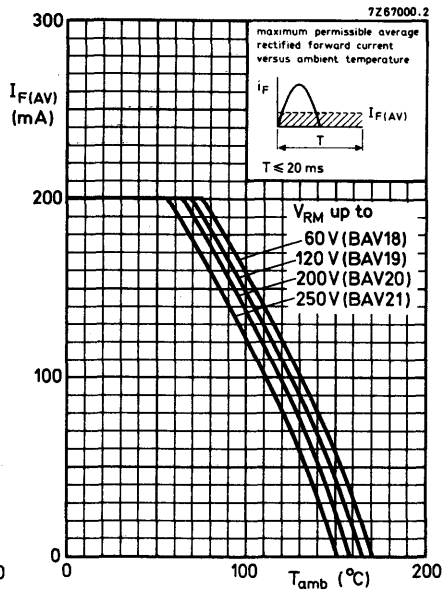
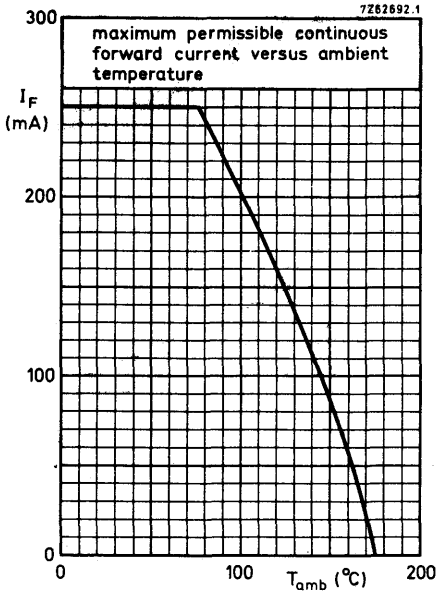

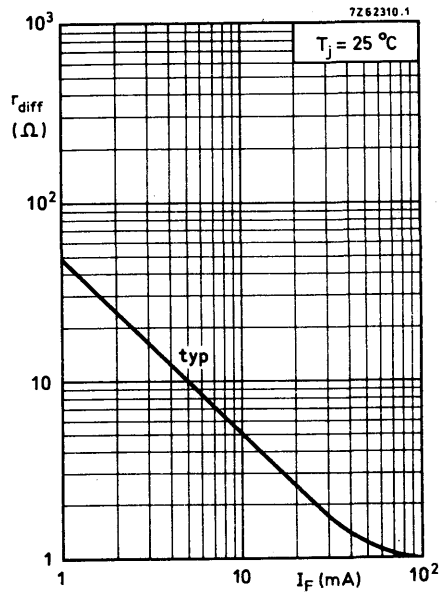
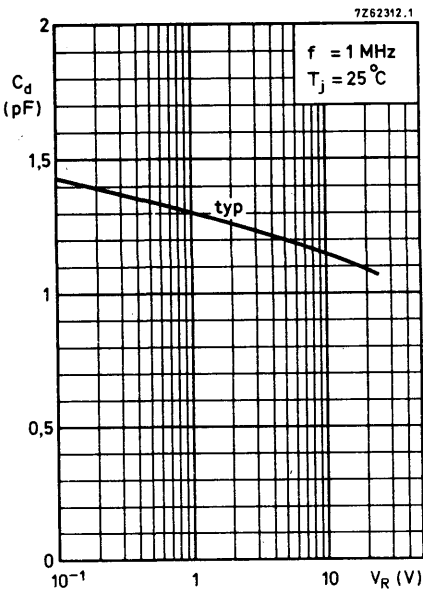
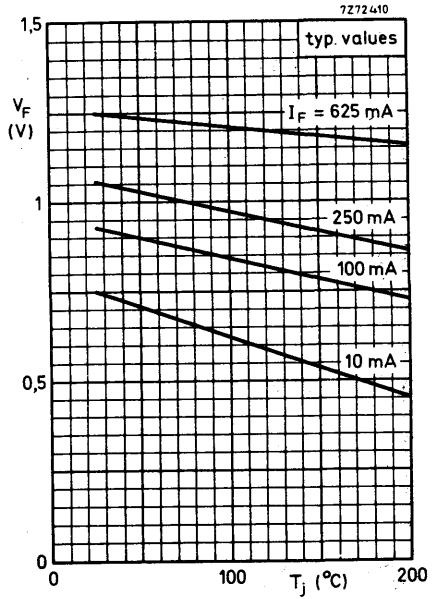
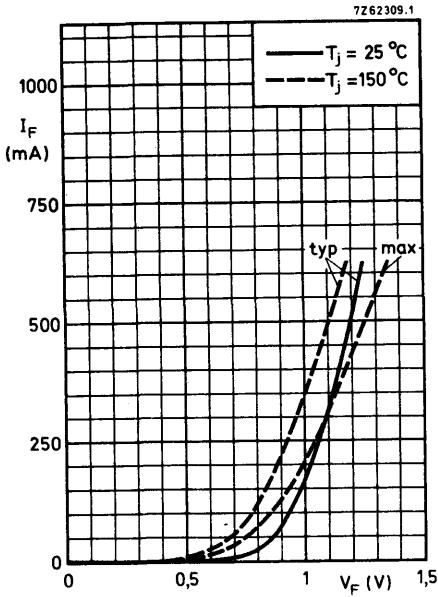

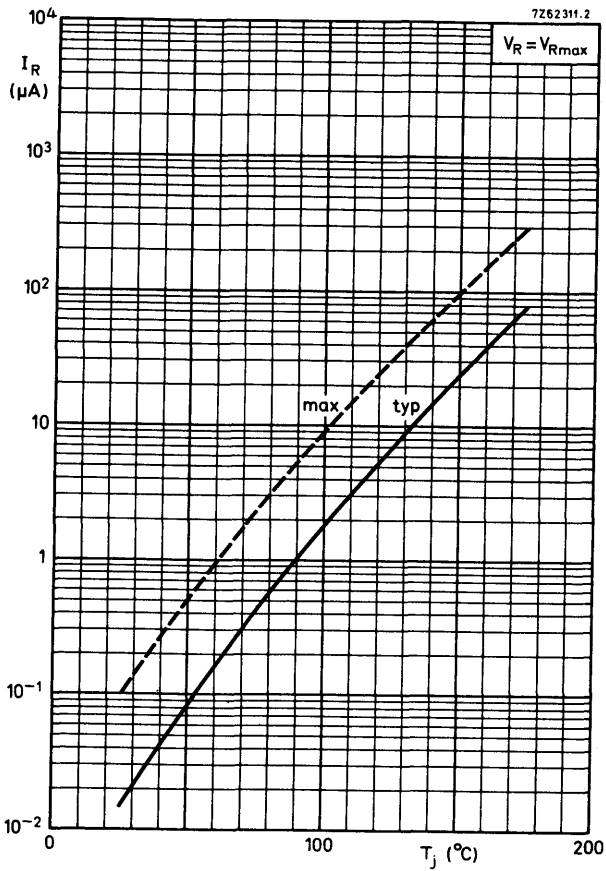

HIGH-SPEED SILICON DIODE



Planar epitaxial high-speed diode in a DO-35 envelope. The BAW62 is primarily intended for fast logic applications.

QUICK REFERENCE DATA

Continuous reverse voltage	V_R	max.	75 V
Repetitive peak reverse voltage	V_{RRM}	max.	75 V
Repetitive peak forward current	I_{FRM}	max.	450 mA
Junction temperature	T_j	max.	200 °C
Forward voltage at $I_F = 100$ mA	V_F	<	1 V
Reverse recovery time when switched from $I_F = 10$ mA to $I_R = 10$ mA; $R_L = 100 \Omega$; measured at $I_R = 1$ mA	t_{rr}	<	4 ns

MECHANICAL DATA

Dimensions in mm

Fig. 1 SOD-27 (DO-35).

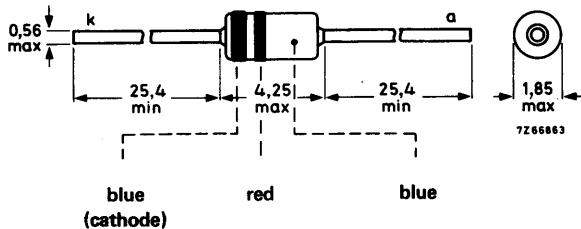

Diodes may be either type-branded or colour-coded.

Products, approved to CECC 50 001-021, available on request.



Mullard

June 1979

1

RATINGS Limiting values in accordance with the Absolute Maximum System (IEC 134)

Voltages

Continuous reverse voltage	V_R	max.	75 V
Repetitive peak reverse voltage	V_{RRM}	max.	75 V ¹⁾

Currents

→ Average rectified forward current	$I_{F(AV)}$	max.	150 mA ²⁾
→ Forward current (d. c.)	I_F	max.	200 mA
→ Repetitive peak forward current	I_{FRM}	max.	450 mA
Non-repetitive peak forward current; $t = 1 \mu s$ $t = 1 s$	I_{FSM}	max.	2000 mA
	I_{FSM}	max.	500 mA

Temperatures

Storage temperature	T_{stg}	-65 to +200 °C
Junction temperature	T_j	max. 200 °C

THERMAL RESISTANCE

From junction to ambient in free air at maximum lead length	$R_{th j-a}$	=	0,6 °C/mW
--	--------------	---	-----------

CHARACTERISTICS

$T_j = 25 \text{ }^\circ\text{C}$ unless otherwise specified

Forward voltages

$I_F = 5 \text{ mA}$	V_F	0,62 to 0,75 V
$I_F = 100 \text{ mA}$	V_F	< 1,00 V
$I_F = 100 \text{ mA}; T_j = 100 \text{ }^\circ\text{C}$	V_F	< 0,93 V

Reverse currents

$V_R = 20 \text{ V}$	I_R	< 25 nA
$V_R = 20 \text{ V}; T_j = 150 \text{ }^\circ\text{C}$	I_R	< 50 μA
$V_R = 50 \text{ V}$	I_R	< 200 nA
$V_R = 75 \text{ V}$	I_R	< 5 μA
$V_R = 75 \text{ V}; T_j = 150 \text{ }^\circ\text{C}$	I_R	< 100 μA

Diode capacitance

$V_R = 0; f = 1 \text{ MHz}$	C_d	< 2 pF
------------------------------	-------	--------

¹⁾ Measured at zero life time at $I_R = 100 \mu\text{A}; V_R > 100 \text{ V}$.

²⁾ For sinusoidal operation see page 6. For pulse operation see page 5.

CHARACTERISTICS (continued)

$T_j = 25\text{ }^\circ\text{C}$

Forward recovery voltage when switched to

$I_F = 50\text{ mA}$; $t_r = 20\text{ ns}$

$V_{fr} < 2,5\text{ V}$

Test circuit and waveforms:

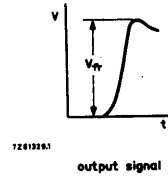
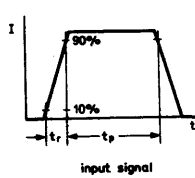
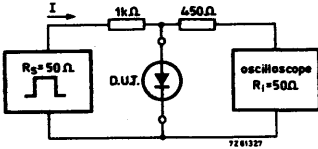

Input signal : Rise time of the forward pulse $t_r = 20\text{ ns}$
 Forward current pulse duration $t_p = 120\text{ ns}$
 Duty factor $\delta = 0,01$

Oscilloscope: Rise time $t_r = 0,35\text{ ns}$

Circuit capacitance $C \leq 1\text{ pF}$ ($C = \text{oscilloscope input capacitance} + \text{parasitic capacitance}$)

Reverse recovery time when switched from

$I_F = 10\text{ mA}$ to $I_R = 10\text{ mA}$; $R_L = 100\text{ }\Omega$;
 measured at $I_R = 1\text{ mA}$

$t_{rr} < 4\text{ ns}$

Test circuit and waveforms:

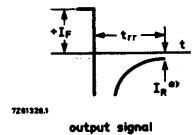
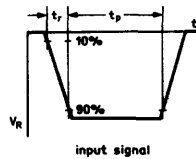
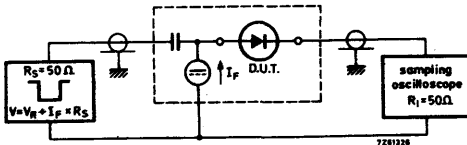

Input signal : Rise time of the reverse pulse $t_r = 0,6\text{ ns}$
 Reverse pulse duration $t_p = 100\text{ ns}$
 Duty factor $\delta = 0,05$

*) $I_R = 1\text{ mA}$

Oscilloscope: Rise time $t_r = 0,35\text{ ns}$

Circuit capacitance $C \leq 1\text{ pF}$ ($C = \text{oscilloscope input capacitance} + \text{parasitic capacitance}$)

CHARACTERISTICS (continued)

$T_j = 25\text{ }^\circ\text{C}$

Recovery charge when switched from

$I_F = 10\text{ mA}$ to $V_R = 5\text{ V}$; $R_L = 500\text{ }\Omega$

Q_S typ. 50 pC

Test circuit and waveform:

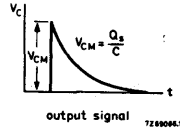
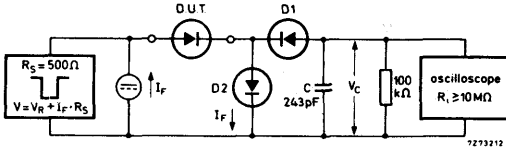

$D1 = D2 = \text{BAW62}$

Input signal : Rise time of the reverse pulse $t_r = 2\text{ ns}$

Reverse pulse duration $t_p = 400\text{ ns}$

Duty factor $\delta = 0,02$

Circuit capacitance $C \leq 7\text{ pF}$ ($C = \text{oscilloscope input capacitance} + \text{parasitic capacitance}$)

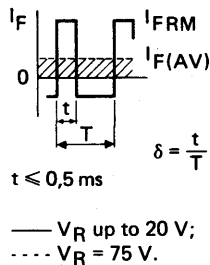
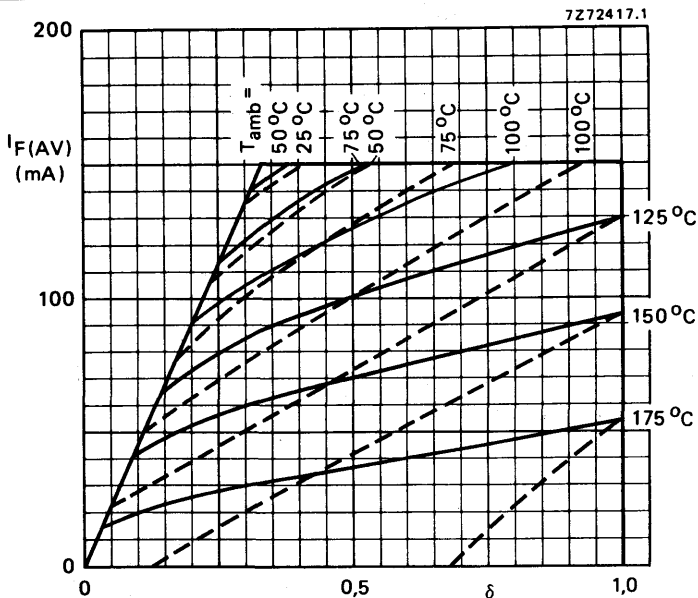

Fig. 8 Maximum permissible average rectified forward current as a function of the duty factor (pulse operated).

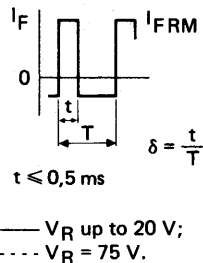
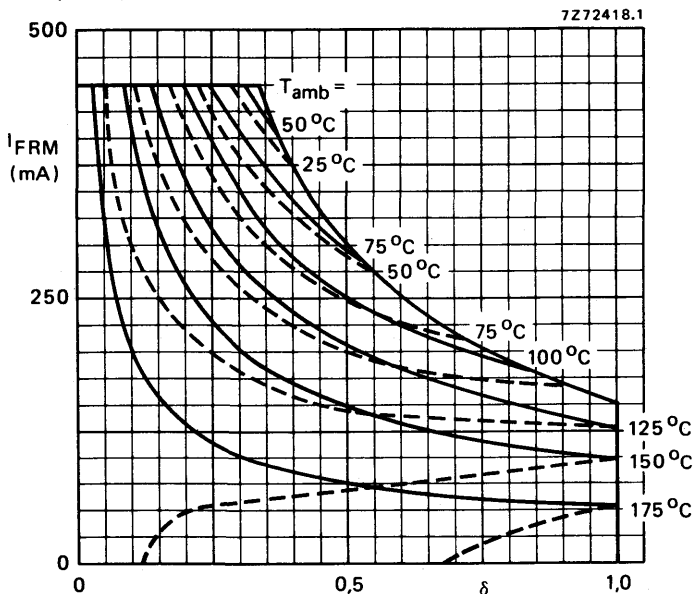

Fig. 9 Maximum permissible repetitive peak forward current as a function of the duty factor (pulse operated).

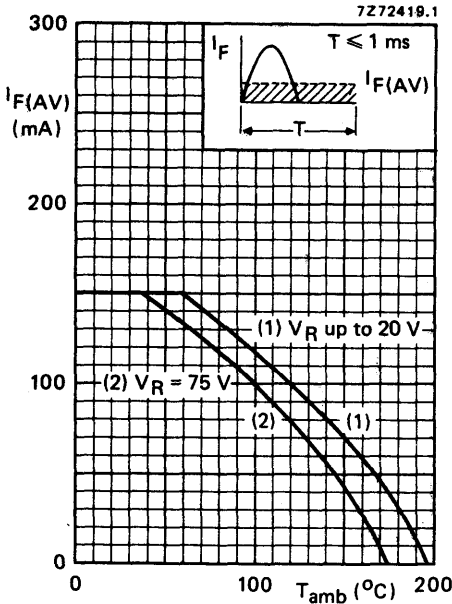

Fig. 10 Maximum permissible average rectified forward current.

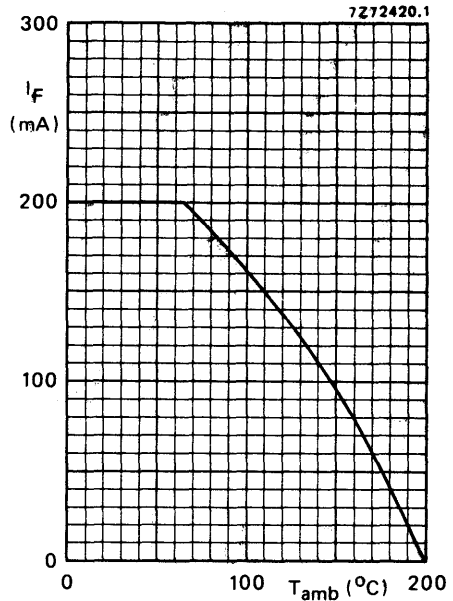

Fig. 11 Maximum permissible continuous forward current.

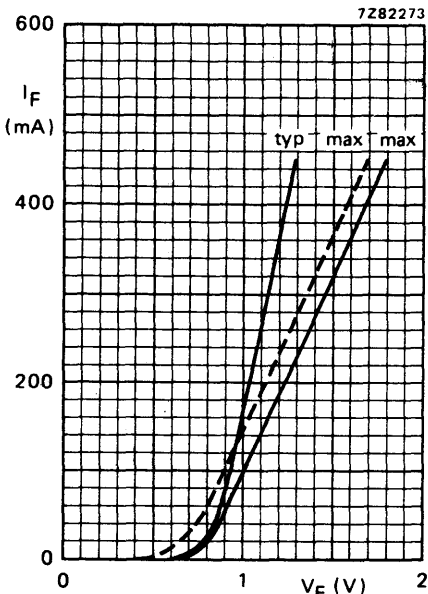

Fig. 12 Forward current as a function forward voltage. — $T_j = 25^{\circ}C$; - - - $T_j = 175^{\circ}C$.

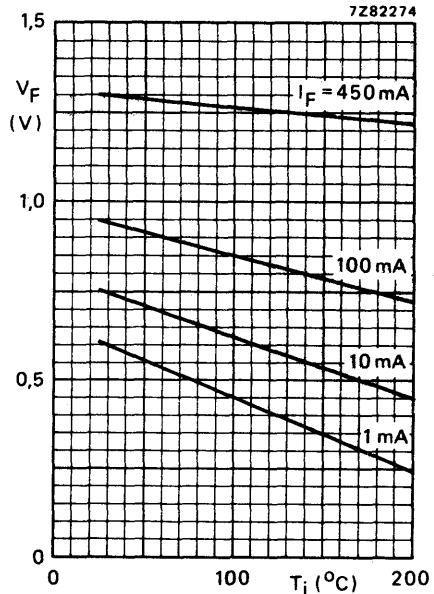
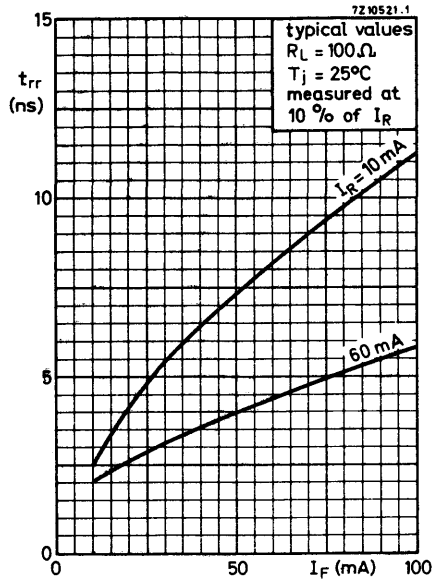
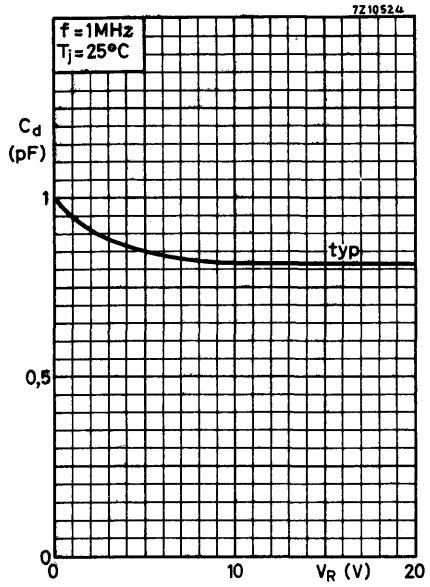
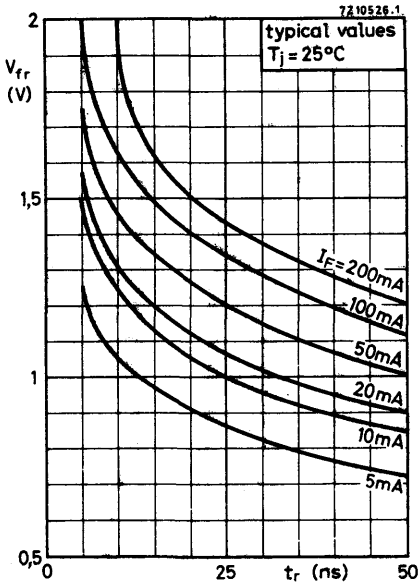
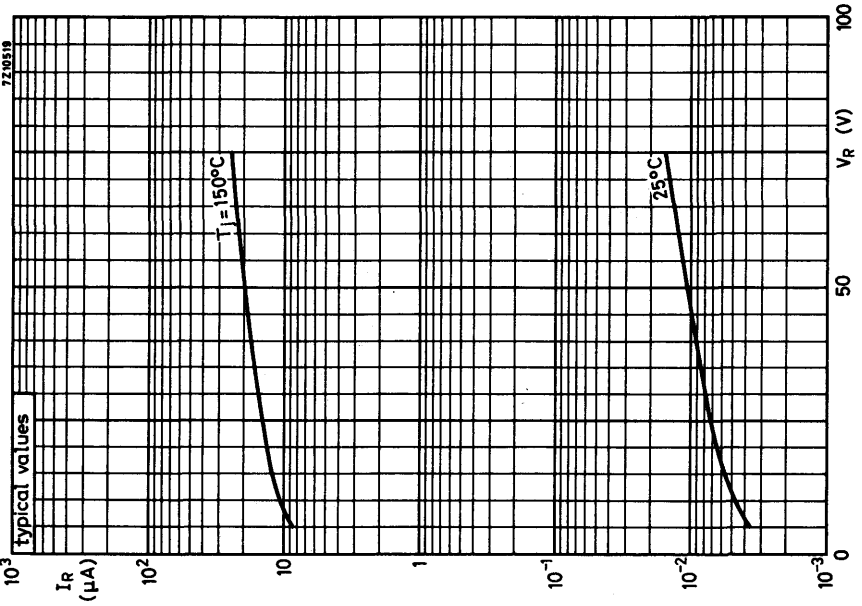
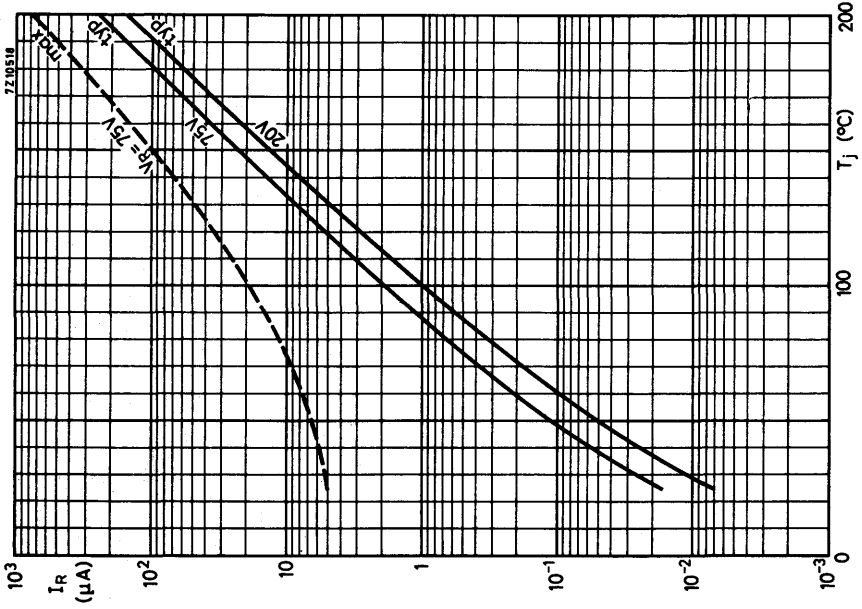

Fig. 13 Typical values forward voltage as a function of junction temperature.





SILICON PLANAR EPITAXIAL CONTROLLED-AVALANCHE DIODE

Diode in a DO-35 envelope primarily intended for switching inductive loads in semi-electronic telephone exchanges.

QUICK REFERENCE DATA			
Repetitive peak forward current	I_{FRM}	max. 0,8	A
Repetitive peak reverse energy $t_p \geq 50 \mu s$; $f \leq 20 \text{ Hz}$; $T_j = 25 \text{ }^\circ\text{C}$	E_{RRM}	max. 5,0	mJ
Thermal resistance from junction to ambient	$R_{th j-a}$	= 0,38	$^\circ\text{C}/\text{mW}$
Forward voltage at $I_F = 200 \text{ mA}$	V_F	< 1,00	V
Reverse avalanche breakdown voltage $I_R = 100 \mu\text{A}$	$V_{(BR)R}$	120 to 175	V
Reverse recovery time when switched from $I_F = 30 \text{ mA}$ to $I_R = 30 \text{ mA}$; $R_L = 100 \Omega$; measured at $I_R = 3 \text{ mA}$	t_{rr}	< 50	ns

MECHANICAL DATA

Dimensions in mm

Fig. 1 SOD-27 (DO-35).

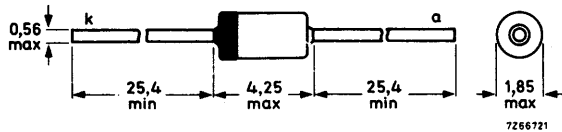

Diodes may be either type-branded or colour-coded.

RATINGS Limiting values in accordance with the Absolute Maximum System (IEC 134)

Voltage

Continuous reverse voltage V_R max. 90 V (1)

Currents

Average rectified forward current
(averaged over any 20 ms period) $I_{F(AV)}$ max. 0,4 A

Forward current (d. c.) I_F max. 0,4 A

Repetitive peak forward current I_{FRM} max. 0,8 A

Non-repetitive peak forward current
 $t = 1 \mu s; T_j = 25 \text{ }^\circ\text{C}$ prior to surge I_{FSM} max. 6,0 A

$t = 1 \text{ s}; T_j = 25 \text{ }^\circ\text{C}$ prior to surge I_{FSM} max. 1,5 A

Repetitive peak reverse current I_{RRM} max. 0,6 A

Reverse energy

Repetitive peak reverse energy
 $t_p \geq 50 \mu s; f \leq 20 \text{ Hz}; T_j = 25 \text{ }^\circ\text{C}$ E_{RRM} max. 5,0 mJ

Temperatures

Storage temperature T_{stg} -65 to +200 $^\circ\text{C}$

Junction temperature T_j max. 200 $^\circ\text{C}$

THERMAL RESISTANCE

From junction to ambient in free air $R_{th j-a} = 0,38 \text{ }^\circ\text{C/mW}$

From junction to ambient in free air
 $T_{lead} = 25 \text{ }^\circ\text{C}$ at 8 mm from the body $R_{th j-a} = 0,30 \text{ }^\circ\text{C/mW}$

(1) It is allowed to exceed this value as described on page 4. Care should be taken not to exceed the I_{RRM} rating.

CHARACTERISTICS

$T_j = 25\text{ }^\circ\text{C}$ unless otherwise specified

Forward voltage

$I_F = 10\text{ mA}$	$V_F < 0,75\text{ V}$
$I_F = 50\text{ mA}$	$V_F < 0,84\text{ V}$
$I_F = 100\text{ mA}$	$V_F < 0,90\text{ V}$
$I_F = 200\text{ mA}$	$V_F < 1,00\text{ V}$
$I_F = 400\text{ mA}$	$V_F < 1,25\text{ V}$

Reverse avalanche breakdown voltage

$I_R = 100\text{ }\mu\text{A}$	$V_{(BR)R} = 120\text{ to }175\text{ V}$
--------------------------------	--

Reverse current

$V_R = 90\text{ V}$	$I_R < 100\text{ nA}$
$V_R = 90\text{ V}; T_j = 150\text{ }^\circ\text{C}$	$I_R < 100\text{ }\mu\text{A}$

Diode capacitance

$V_R = 0; f = 1\text{ MHz}$	C_d	typ. 15 pF
		< 35 pF

Reverse recovery time when switched from

$I_F = 30\text{ mA}$ to $I_R = 30\text{ mA}; R_L = 100\text{ }\Omega$; measured at $I_R = 3\text{ mA}$	$t_{rr} < 50\text{ ns}$
--	-------------------------

Test circuit and waveforms :

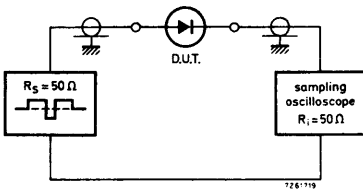

Fig. 2.

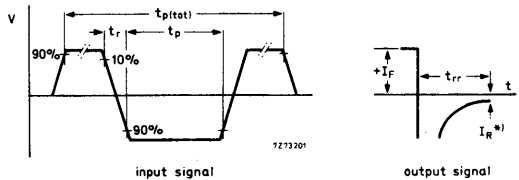

Fig. 3.

Input signal : Total pulse duration	$t_p(\text{tot}) = 2\text{ }\mu\text{s}$	*) $I_R = 3\text{ mA}$
Duty factor	$\delta = 0,0025$	
Rise time of the reverse pulse	$t_r = 0,6\text{ ns}$	
Reverse pulse duration	$t_p = 100\text{ ns}$	
Oscilloscope : Rise time	$t_r = 0,35\text{ ns}$	
Circuit capacitance $C \leq 1\text{ pF}$ ($C = \text{oscilloscope input capacitance} + \text{parasitic capacitance}$)		

Reverse voltages higher than the V_R ratings are allowed, provided:

- a. the transient energy $\leq 7,5$ mJ at $P_{RRM} \leq 30$ W; $T_j = 25$ °C
 the transient energy ≤ 5 mJ at $P_{RRM} \leq 120$ W; $T_j = 25$ °C (see Fig. 8).
- b. $T \geq 5$ ms; $\delta \leq 0,01$ (rectangular waveform)
 $\delta \leq 0,02$ (triangular waveform).

With increasing temperature, the maximum permissible transient energy must be decreased by 0,03 mJ/°C.

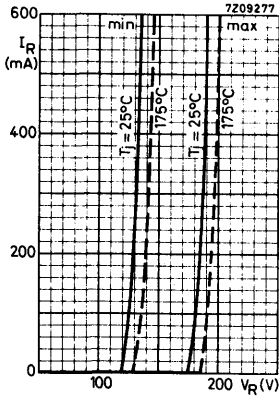

Fig. 4.

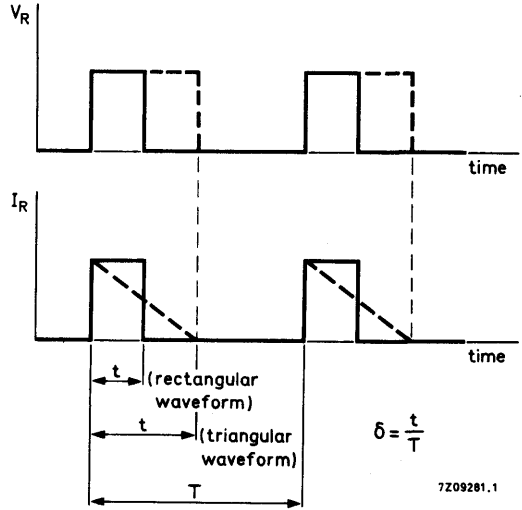

Fig. 5.

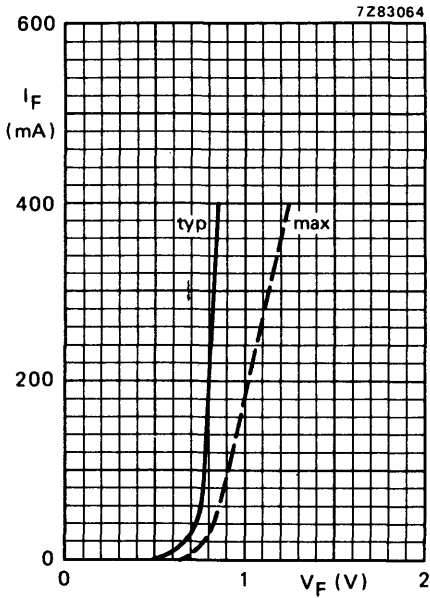

Fig. 6 I_F as a function of V_F at $T_j = 25\text{ }^\circ\text{C}$.

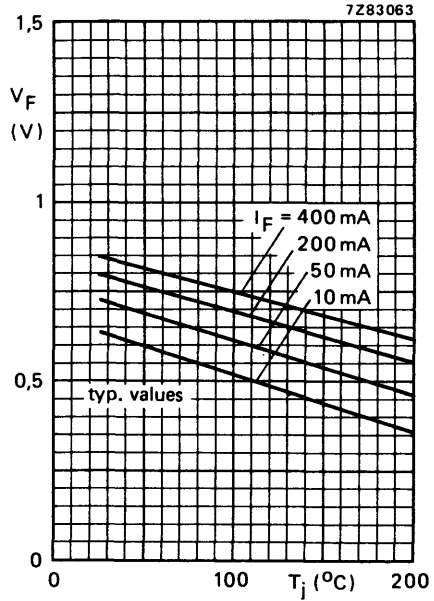

Fig. 7 V_F as a function of T_j .

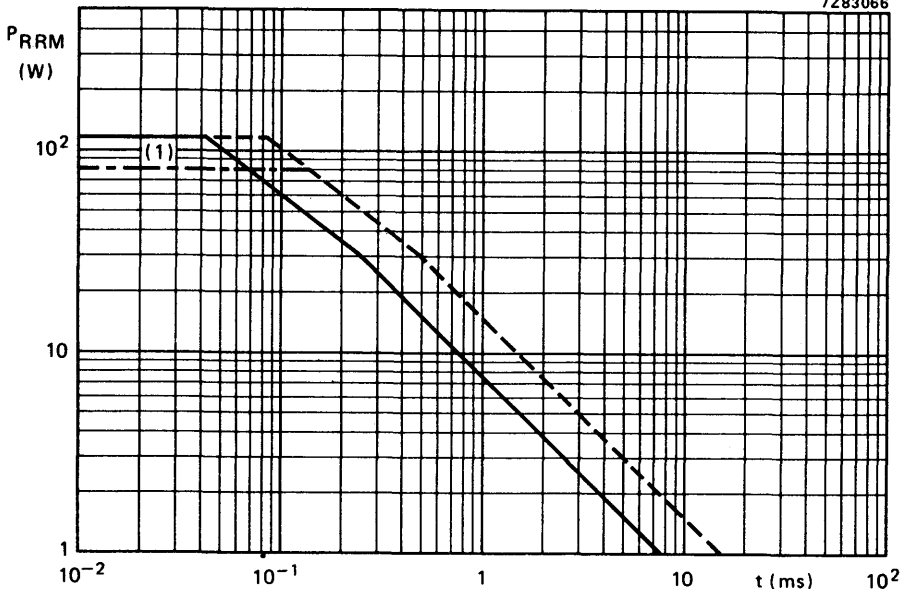

Fig. 8 Maximum permissible repetitive peak reverse power as a function of the pulse duration $T \geq 50\text{ ms}$; $T_j = 25\text{ }^\circ\text{C}$. — rectangular waveform; $\delta \leq 0,01$; - - - triangular waveform; $\delta \leq 0,02$.

(1) Limited by $I_{RRM} = 600\text{ mA}$.

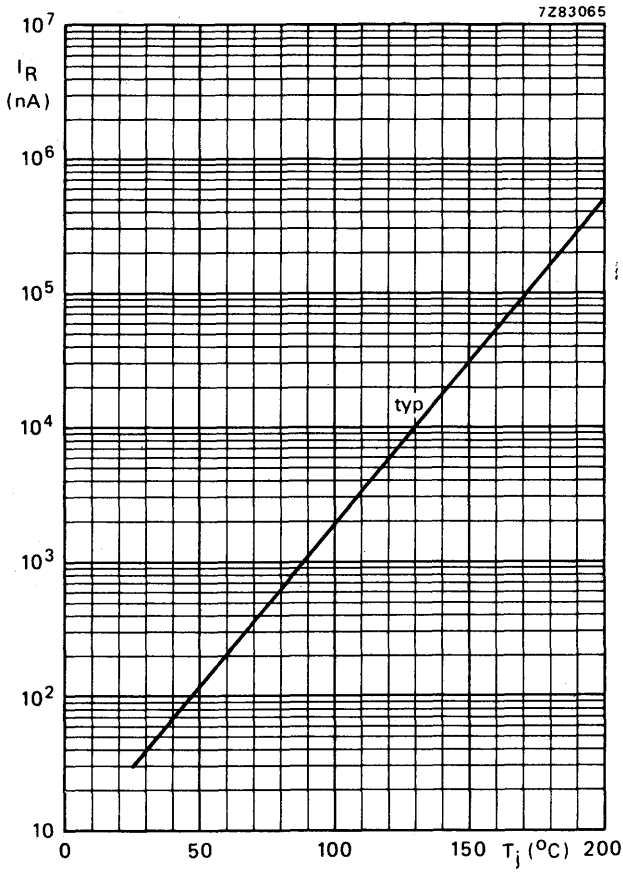

Fig. 9 Typical values reverse current as a function of junction temperature at $V_R = 90 \text{ V}$.

SILICON OXIDE PASSIVATED DIODE

Whiskerless diode in a glass subminiature envelope.
The BAX13 is primarily intended for general purpose applications.

QUICK REFERENCE DATA

Continuous reverse voltage	V_R	max.	50 V
Repetitive peak reverse voltage	V_{RRM}	max.	50 V
Repetitive peak forward current	I_{FRM}	max.	150 mA
Thermal resistance from junction to ambient	$R_{th\ j-a}$	=	0,60 °C/mW
Forward voltage at $I_F = 20$ mA	V_F	<	1,0 V
Reverse recovery time when switched from $I_F = 10$ mA to $I_R = 60$ mA; $R_L = 100 \Omega$ measured at $I_R = 1$ mA	t_{rr}	<	4 ns
Recovery charge when switched from $I_F = 10$ mA to $V_R = 5$ V; $R_L = 500 \Omega$	Q_s	<	45 pC

MECHANICAL DATA

Dimensions in mm

DO - 35

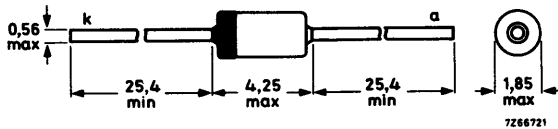

The coloured end indicates the cathode
The diodes may be type-branded or colour coded.

RATINGS Limiting values in accordance with the Absolute Maximum System (IEC 134)

Voltages

Continuous reverse voltage	V_R	max.	50	V
Repetitive peak reverse voltage	V_{RRM}	max.	50	V

Currents

Average rectified forward current (averaged over any 20 ms period)	$I_{F(AV)}$	max.	75	mA ¹⁾
Forward current (d. c.)	I_F	max.	75	mA
Repetitive peak forward current	I_{FRM}	max.	150	mA
Non-repetitive peak forward current t = 1 μ s	I_{FSM}	max.	2000	mA
t = 1 s	I_{FSM}	max.	500	mA

Temperatures

Storage temperature	T_{stg}	-65 to +200	$^{\circ}$ C
Junction temperature	T_j	max. 200	$^{\circ}$ C

THERMAL RESISTANCE

From junction to ambient in free air	$R_{th\ j-a}$	=	0,60	$^{\circ}$ C/mW
--------------------------------------	---------------	---	------	-----------------

CHARACTERISTICS

$T_j = 25\ ^{\circ}$ C unless otherwise specified

Forward voltage

$I_F = 2\ \text{mA}$	V_F	<	0,7	V
$I_F = 10\ \text{mA}; T_j = 100\ ^{\circ}\text{C}$	V_F	<	0,8	V
$I_F = 20\ \text{mA}$	V_F	<	1,0	V ²⁾
$I_F = 75\ \text{mA}$	V_F	<	1,53	V ²⁾

Reverse current

$V_R = 10\ \text{V}$	I_R	<	25	nA
$V_R = 10\ \text{V}; T_j = 150\ ^{\circ}\text{C}$	I_R	<	10	μ A
$V_R = 25\ \text{V}$	I_R	<	50	nA
$V_R = 50\ \text{V}$	I_R	<	200	nA
$V_R = 50\ \text{V}; T_j = 150\ ^{\circ}\text{C}$	I_R	<	25	μ A

Diode capacitance (see also page 7)

$V_R = 0; f = 1\ \text{MHz}$	C_d	<	3	pF
------------------------------	-------	---	---	----

1) For sinusoidal operation see page 5.
For pulse operation see page 6.

2) Measured under pulse conditions to avoid excessive dissipation.

CHARACTERISTICS (continued)

$T_j = 25 \text{ }^\circ\text{C}$

Forward recovery voltage (see also page 7)

At $t_{rF} > 20 \text{ ns}$, V_{fR} will not exceed V_F corresponding to $I_{fR} = 1 \text{ to } 75 \text{ mA}$

Test circuit and waveforms :

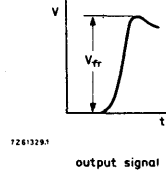
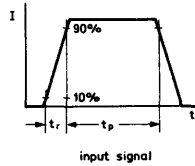
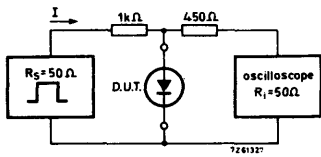

Input signal : Rise time of the forward pulse $t_{rF} = 20 \text{ ns}$
 Forward current pulse duration $t_{pF} = 120 \text{ ns}$
 Duty factor $\delta = 0,01$

Oscilloscope : Rise time $t_r = 0,35 \text{ ns}$

Circuit capacitance $C \leq 1 \text{ pF}$ ($C = \text{oscilloscope input capacitance} + \text{parasitic capacitance}$)

Reverse recovery time when switched from

$I_{fR} = 10 \text{ mA}$ to $I_{rR} = 10 \text{ mA}$; $R_L = 100 \text{ } \Omega$; measured at $I_{rR} = 1 \text{ mA}$ $t_{rR} < 6 \text{ ns}$ ¹⁾
 $I_{fR} = 10 \text{ mA}$ to $I_{rR} = 60 \text{ mA}$; $R_L = 100 \text{ } \Omega$; measured at $I_{rR} = 1 \text{ mA}$ $t_{rR} < 4 \text{ ns}$

Test circuit and waveforms :

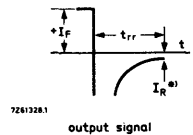
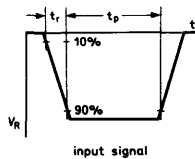
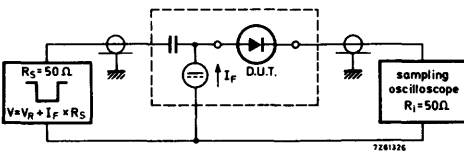

Input signal : Rise time of the reverse pulse $t_{rR} = 0,6 \text{ ns}$ ^{*)} $I_{rR} = 1 \text{ mA}$
 Reverse pulse duration $t_{pR} = 100 \text{ ns}$
 Duty factor $\delta = 0,05$

Oscilloscope : Rise time $t_r = 0,35 \text{ ns}$

Circuit capacitance $C \leq 1 \text{ pF}$ ($C = \text{oscilloscope input capacitance} + \text{parasitic capacitance}$)

¹⁾ See also page 8.

CHARACTERISTICS (continued)

$T_j = 25\text{ }^\circ\text{C}$

Recovery charge when switched from

$$I_F = 10\text{ mA to } V_R = 5\text{ V; } R_L = 500\ \Omega$$

$$Q_S < 45\text{ pC}$$

Test circuit and waveform:

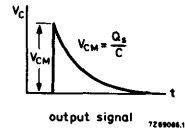
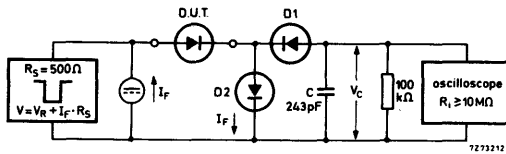

$D1 = D2 = \text{BAW62}$

Input signal: Rise time of the reverse pulse

$$t_r = 2\text{ ns}$$

Reverse pulse duration

$$t_p = 400\text{ ns}$$

Duty factor

$$\delta = 0,02$$

Circuit capacitance $C \leq 7\text{ pF}$ ($C = \text{oscilloscope input capacitance} + \text{parasitic capacitance}$)

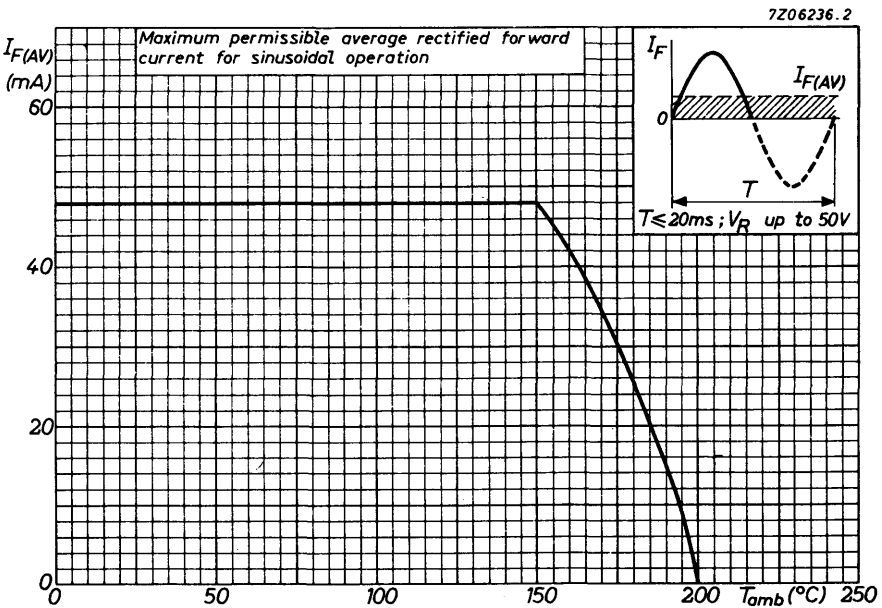
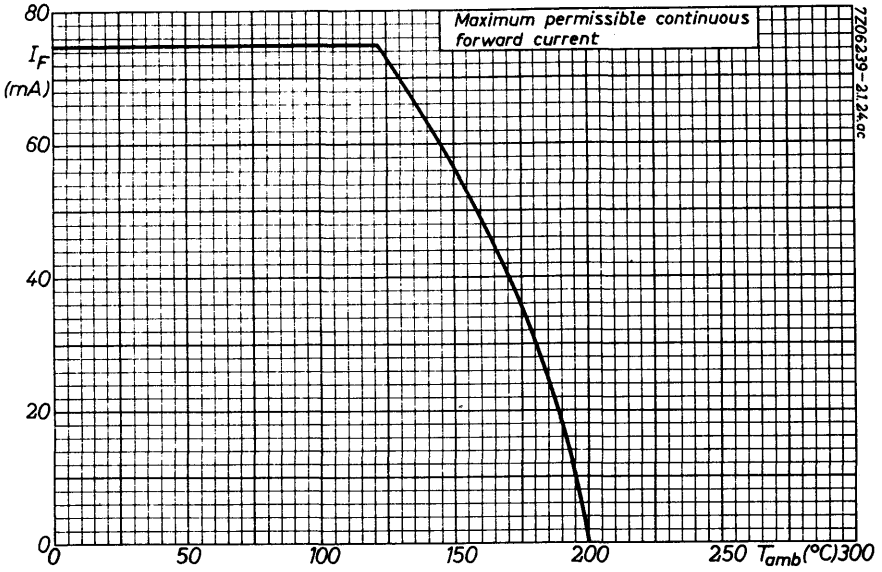

7272423

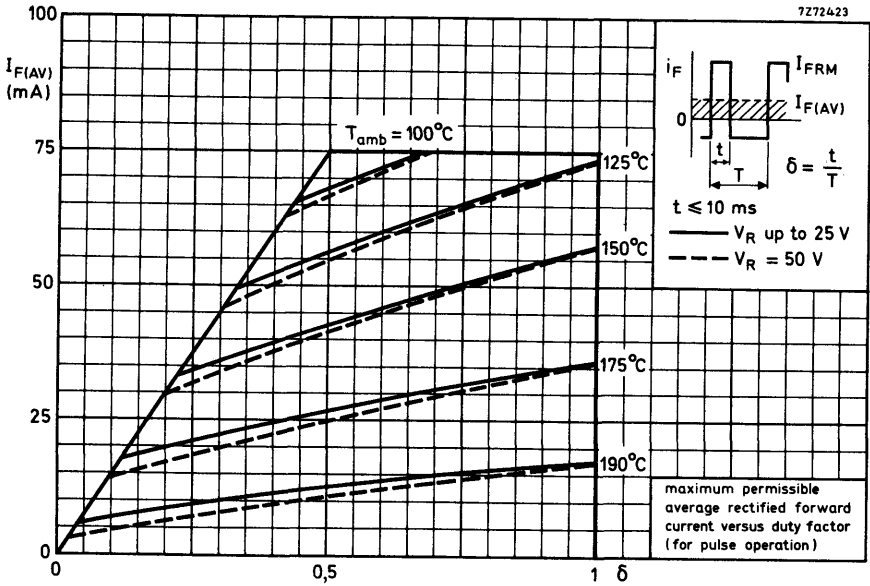

7272424

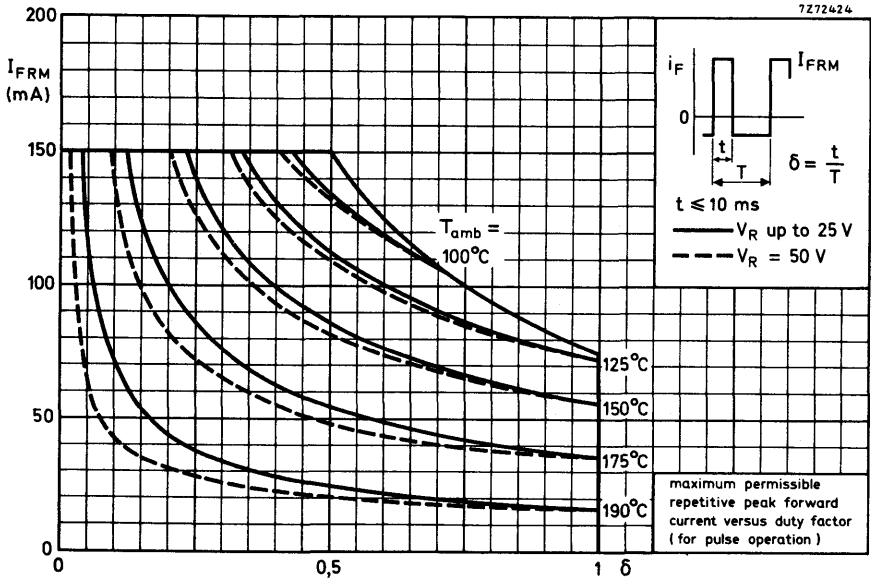

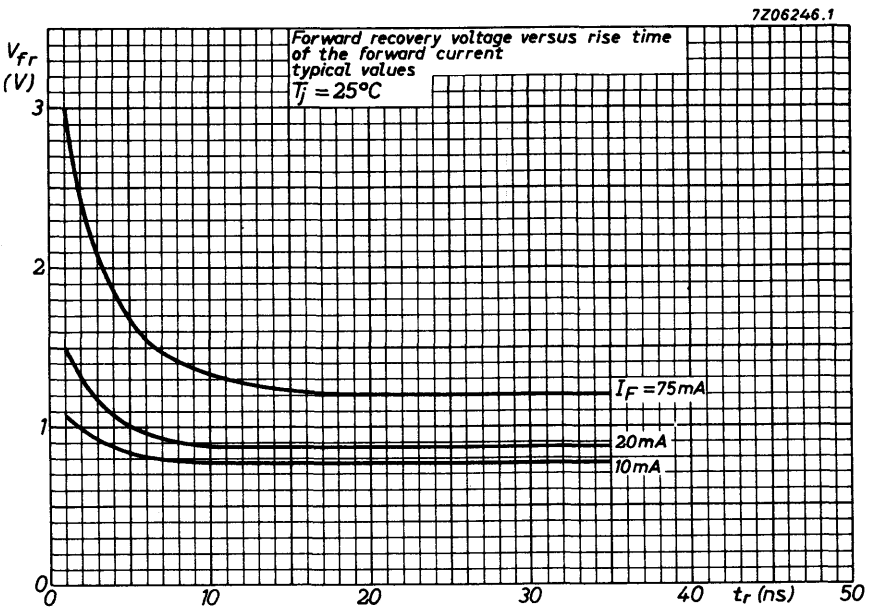
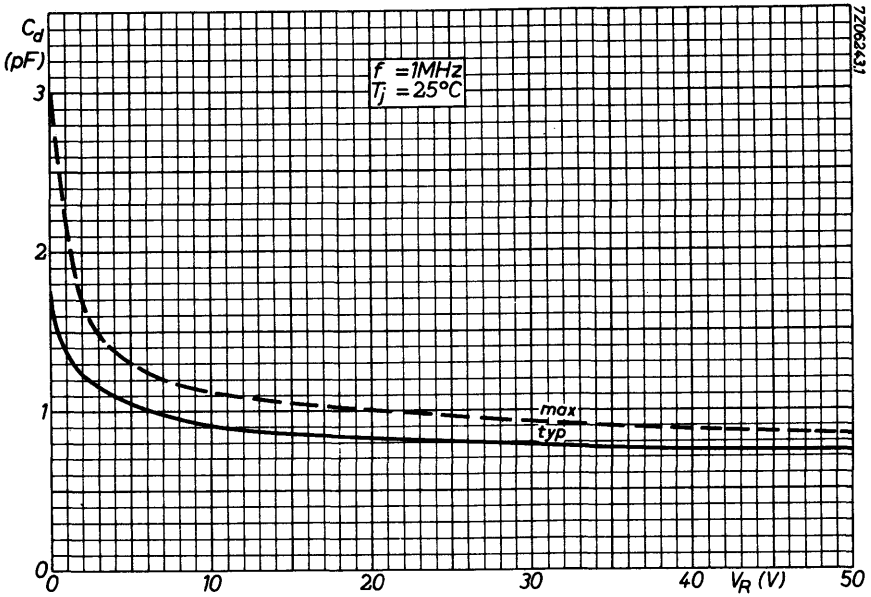

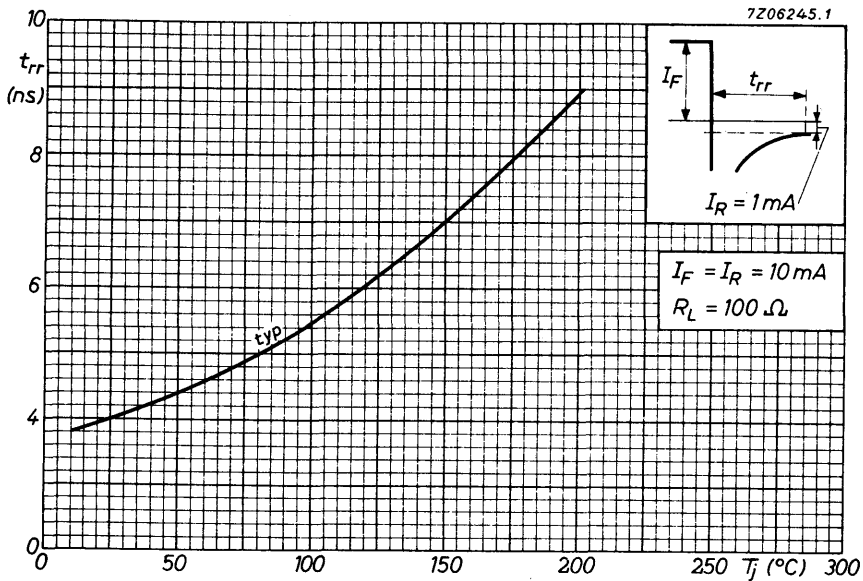
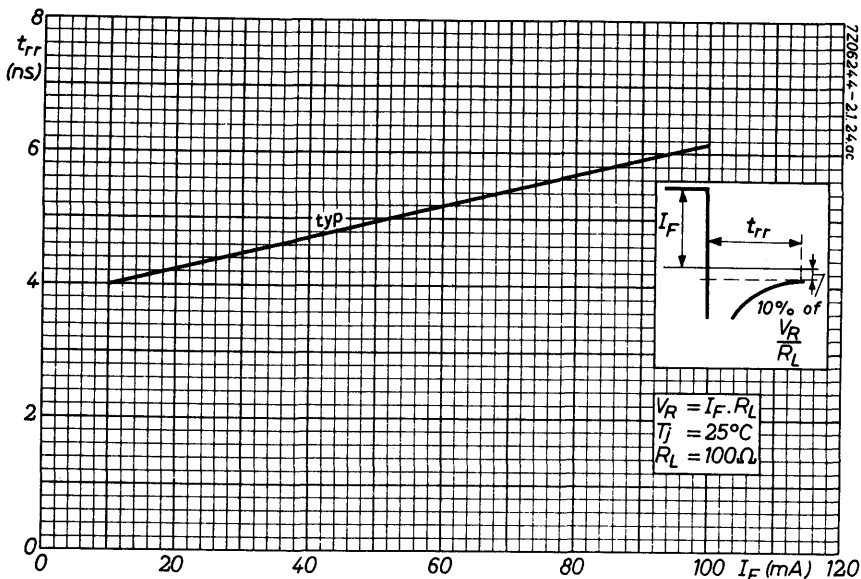

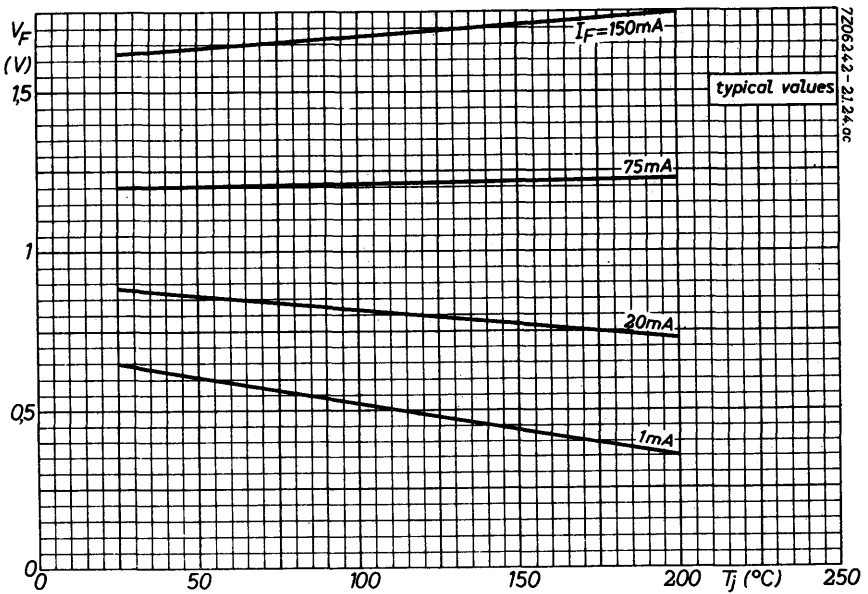
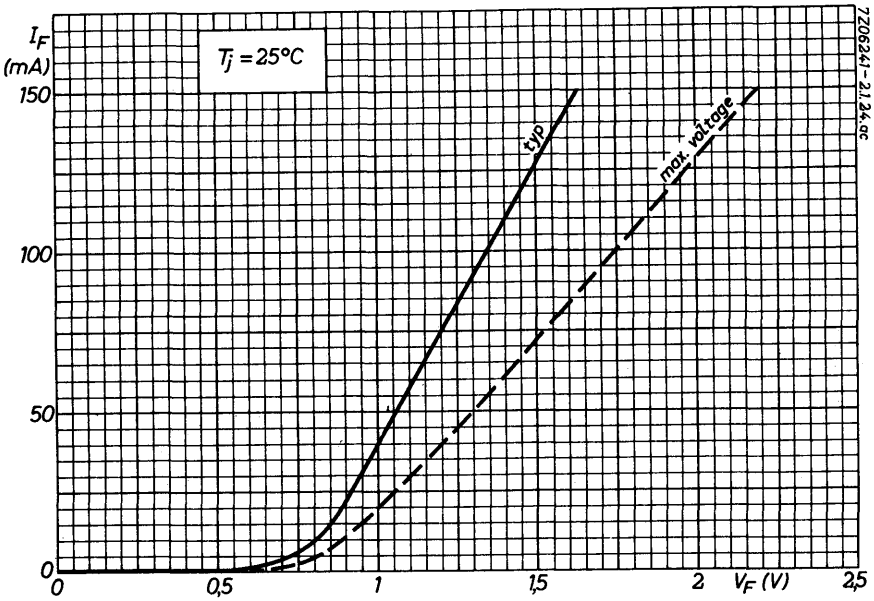

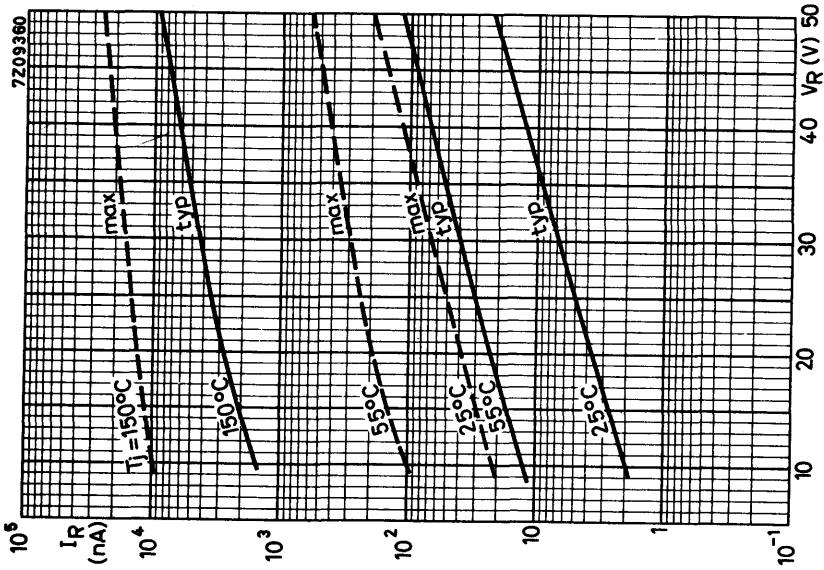
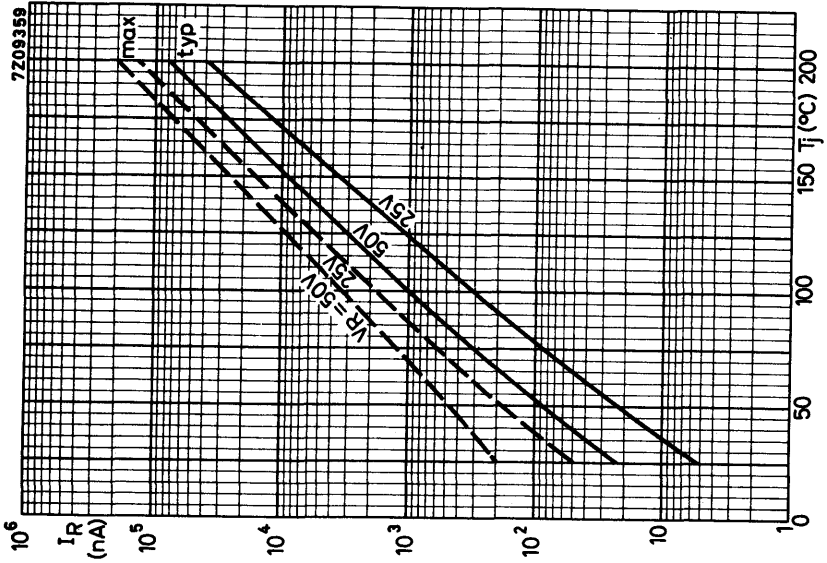

SILICON WHISKERLESS DIODES



Whiskerless diffused silicon diodes intended for general purpose industrial applications.

QUICK REFERENCE DATA

	BAX16	BAX17	
V_R max.	150	200	V
V_F max. $I_F = 100\text{mA}$	1.3	-	V
$I_F = 200\text{mA}$	-	1.2	V
I_{FRM} max.	300		mA
t_{rr} max. (when switched from $I_F = 30\text{mA}$ to $V_R = 3.0\text{V}$)	120		ns
Q_s max. (when switched from $I_F = 10\text{mA}$ to $V_R = 5.0\text{V}$)	0.7		nC

Unless otherwise stated, data is applicable to both types

OUTLINE AND DIMENSIONS

Dimensions in mm

DO-35

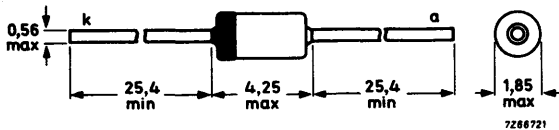

The coloured end indicates the cathode
The diodes may be either type-branded or colour-coded.

Products approved to CECC 50 001-022, available on request.



RATINGS

Limiting values of operation according to the absolute maximum system.

Electrical		BAX16	BAX17	
V_R	Max. continuous reverse voltage	150	200	V
V_{RRM}	Max. repetitive peak reverse voltage	150	200	V
$I_{F(AV)}$	Max. average forward current (averaging time = 20ms)		200	mA
I_F	Max. continuous forward current		200	mA
I_{FRM}	Max. repetitive peak forward current		300	mA
I_{FSM}	Max. non-repetitive peak forward current			
	max. duration 1.0 μ s		2500	mA
	max. duration 1.0s		500	mA

Temperature

T_{stg} range	-65 to +200	$^{\circ}$ C
T_j max.	+200	$^{\circ}$ C

THERMAL CHARACTERISTIC

$R_{th(j-amb)}$	0.50	degC/mW
-----------------	------	---------

ELECTRICAL CHARACTERISTICS ($T_j = 25^{\circ}$ C unless otherwise stated)

		BAX16 Max.	BAX17 Max.	
V_F	Forward voltage			
	$I_F = 1.0$ mA	0.65	0.65	V
	$I_F = 10$ mA, $T_j = 100^{\circ}$ C	0.85	0.75	V
	$\dagger I_F = 100$ mA	1.3*	1.1	V
	$\dagger I_F = 200$ mA	1.5	1.2*	V
	$\dagger I_F = 200$ mA, $T_j = 175^{\circ}$ C	1.4	1.2	V
I_R	Reverse current			
	$V_R = 50$ V	25	25	nA
	$V_R = 50$ V, $T_j = 150^{\circ}$ C	25	25	μ A
	$V_R = 150$ V	100**	100**	nA
	$V_R = V_{RRM}$ max., $T_j = 150^{\circ}$ C	100	100	μ A
C_d	Diode capacitance			
	$V_R = 0$, $f = 1.0$ MHz	10	10	pF

*These are the characteristics which are recommended for acceptance testing purposes.

\dagger Measured under pulse conditions to prevent excessive dissipation.

		Typ.	Max.	
t_{rr}	Reverse recovery time when switched from $I_F = 30\text{mA}$ to $V_R = 3.0\text{V}$, $R_L = 100\Omega$ measured at $I_R = 1.0\text{mA}$	70	120	ns

Test circuit

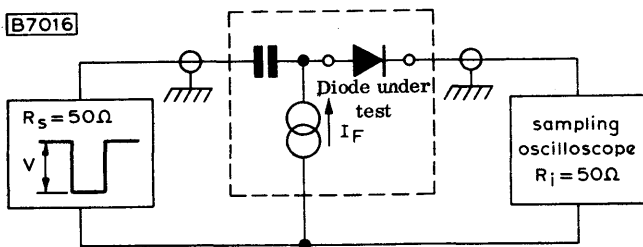

Circuit capacitance $\leq 1.0\text{pF}$ (C.R.O. + stray capacitance)

C.R.O. rise time = 0.35ns

$$V = V_R + I_F \times R_s$$

Input pulse

t_r	Rise time	0,6 ns
t_p	Pulse duration	100 ns
d	Duty cycle	0,05

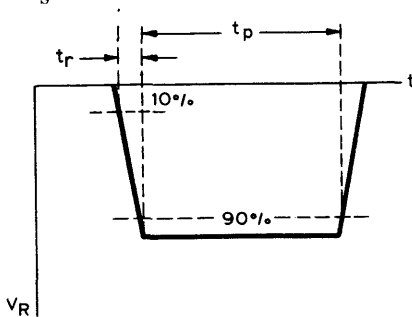

Output waveform

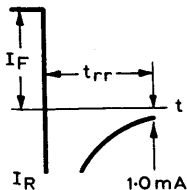

Max.
0.7* nC

Q_s

Recovered charge when
switched from $I_F = 10\text{mA}$ to $V_R = 5.0\text{V}$,
 $R_L = 500\Omega$

Test circuit

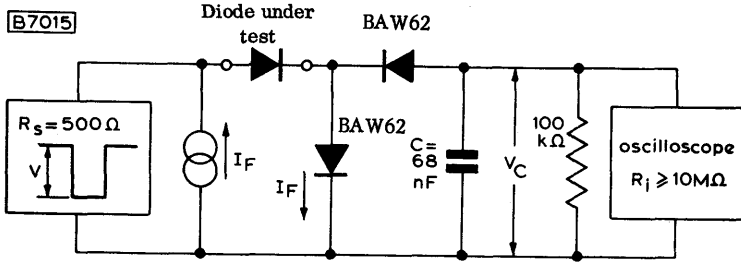

Circuit capacitance $\leq 30\text{pF}$ (C. R. O. + stray capacitance)

$$V = V_R + I_F \times R_s$$

Input pulse

t_r	Rise time	15	ns
t_p	Pulse duration	35	μs
f	Frequency	25	kHz

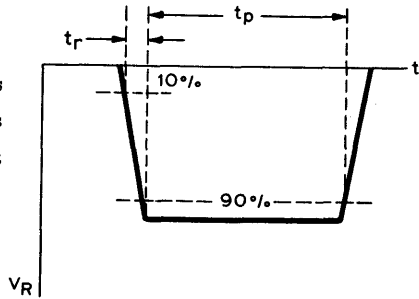

Output waveform

$$V_p = \frac{Q_s}{C}$$

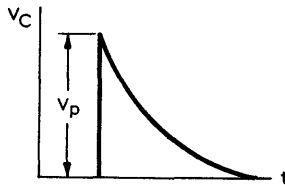

*These are the characteristics which are recommended for acceptance testing purposes.

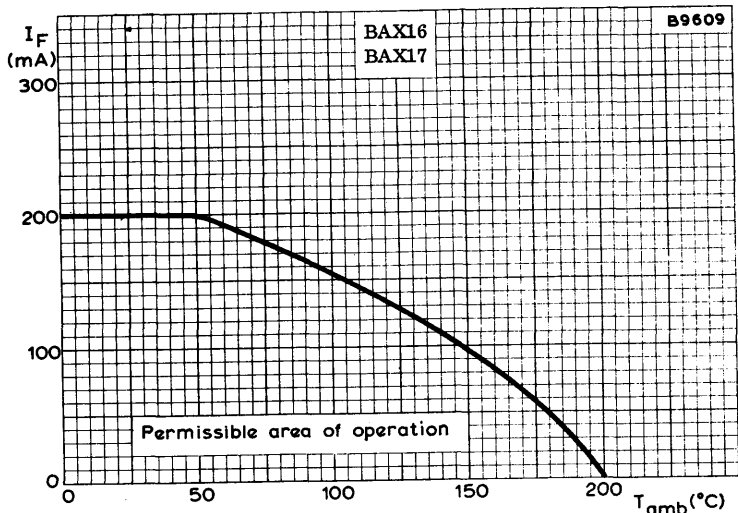

CONTINUOUS FORWARD CURRENT PLOTTED AGAINST AMBIENT TEMPERATURE

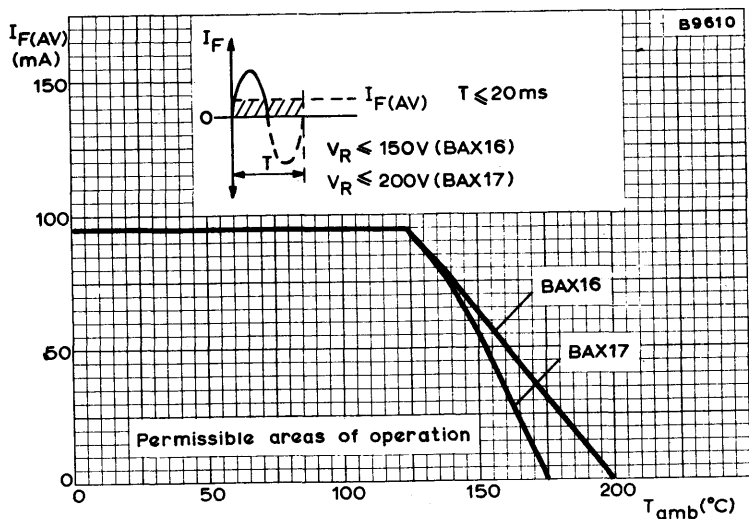

AVERAGE RECTIFIED FORWARD CURRENT PLOTTED AGAINST AMBIENT TEMPERATURE

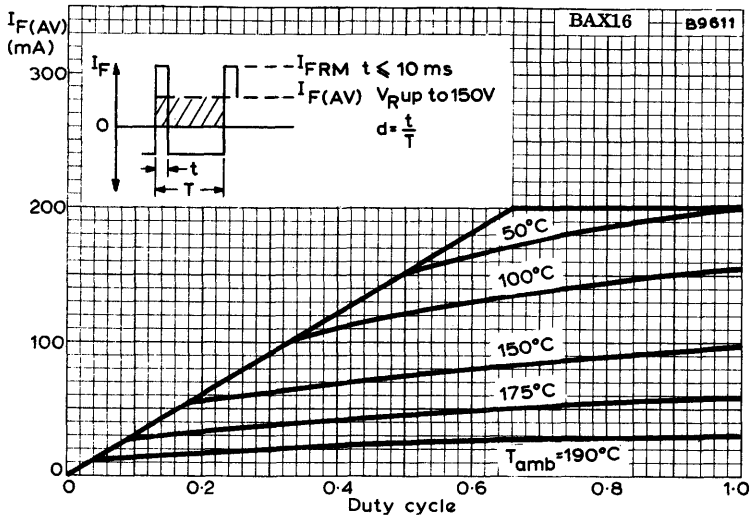

MAXIMUM PERMISSIBLE AVERAGE FORWARD CURRENT PLOTTED AGAINST DUTY CYCLE

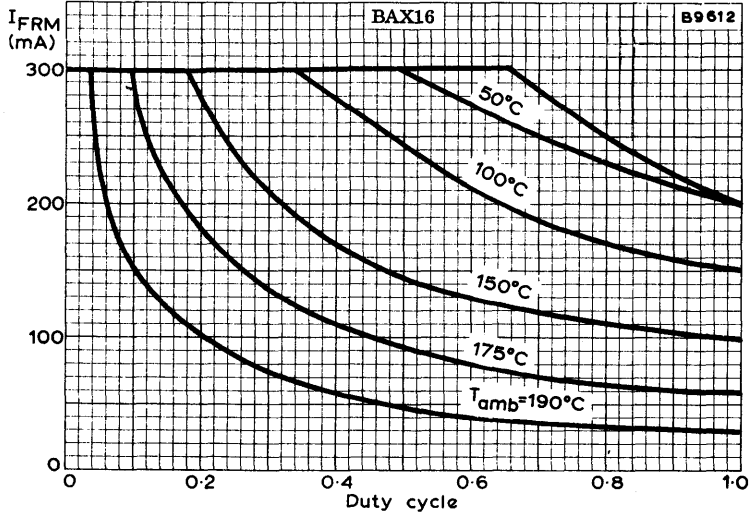

MAXIMUM PERMISSIBLE REPETITIVE PEAK FORWARD CURRENT PLOTTED AGAINST DUTY CYCLE

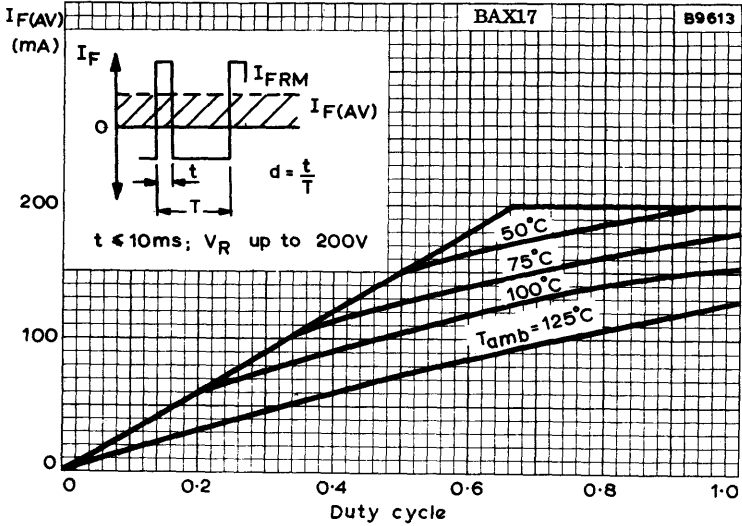

**MAXIMUM PERMISSIBLE AVERAGE FORWARD CURRENT
PLOTTED AGAINST DUTY CYCLE**

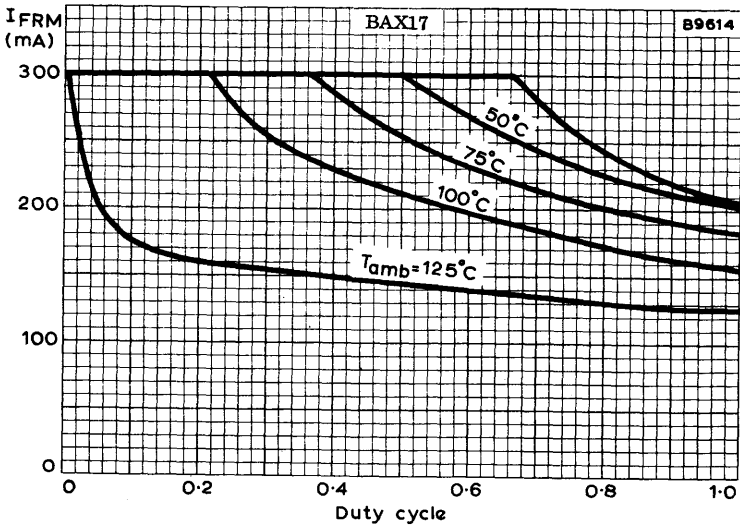

**MAXIMUM PERMISSIBLE REPETITIVE PEAK FORWARD CURRENT
PLOTTED AGAINST DUTY CYCLE**

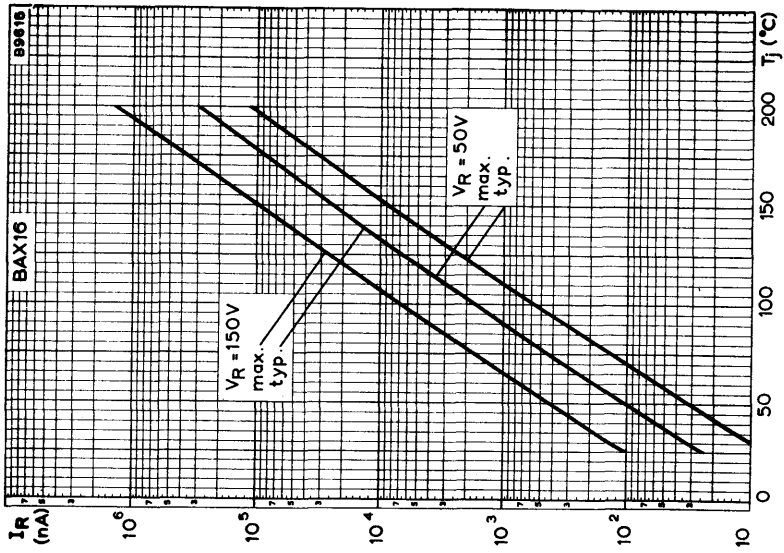
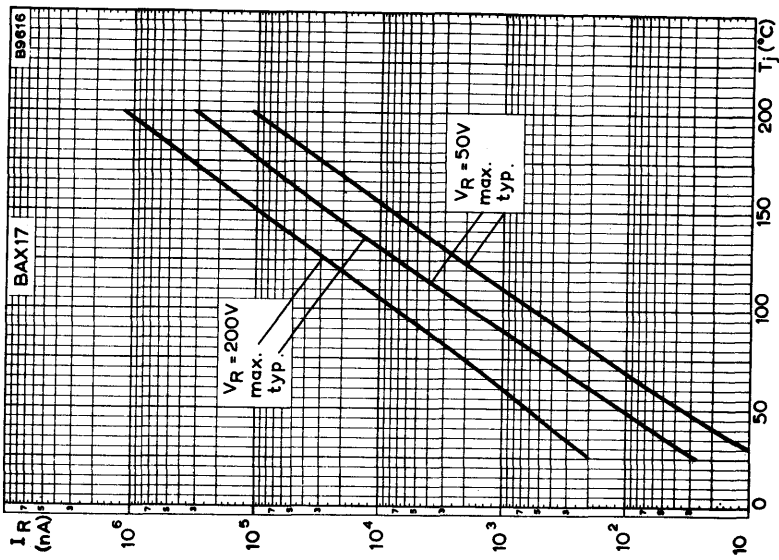

REVERSE CURRENT PLOTTED AGAINST JUNCTION TEMPERATURE
WITH REVERSE VOLTAGE AS A PARAMETER

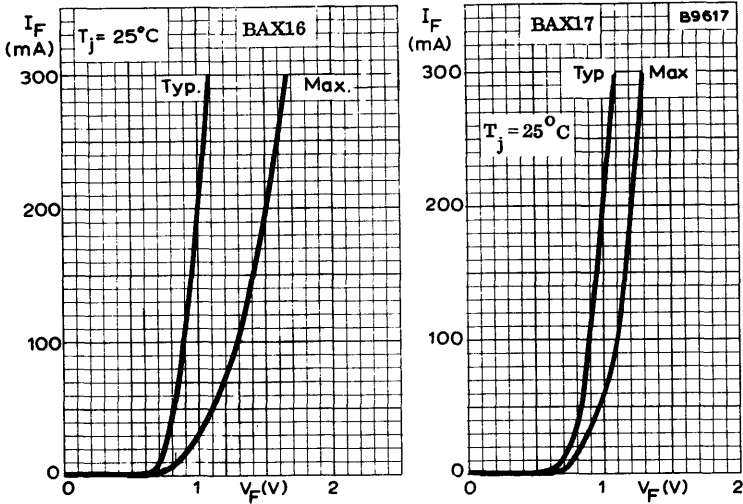

FORWARD CHARACTERISTICS

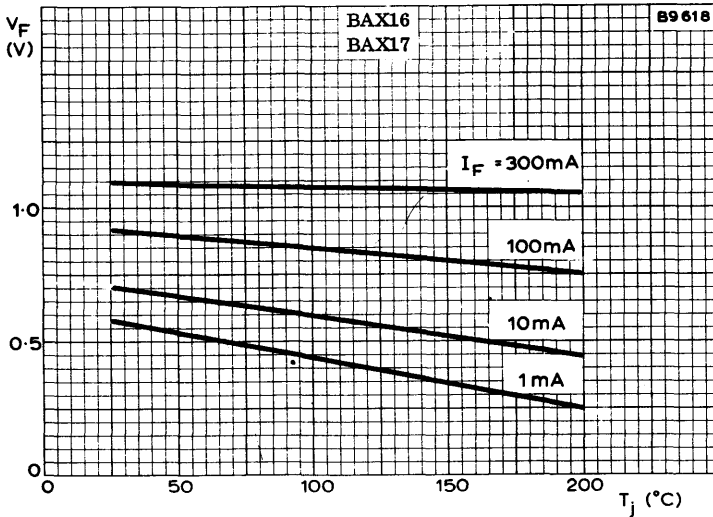

TYPICAL FORWARD VOLTAGE PLOTTED AGAINST JUNCTION TEMPERATURE WITH FORWARD CURRENT AS A PARAMETER

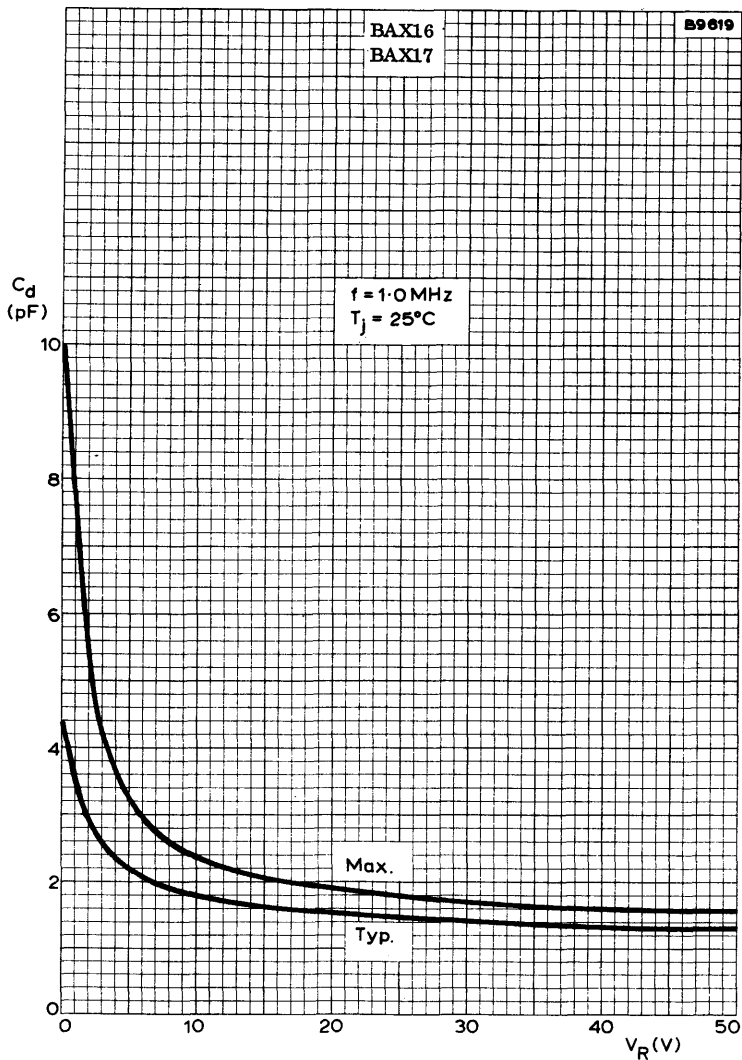

DIODE CAPACITANCE PLOTTED AGAINST REVERSE VOLTAGE

**SILICON
WHISKERLESS DIODES**

**BAX16
BAX17**

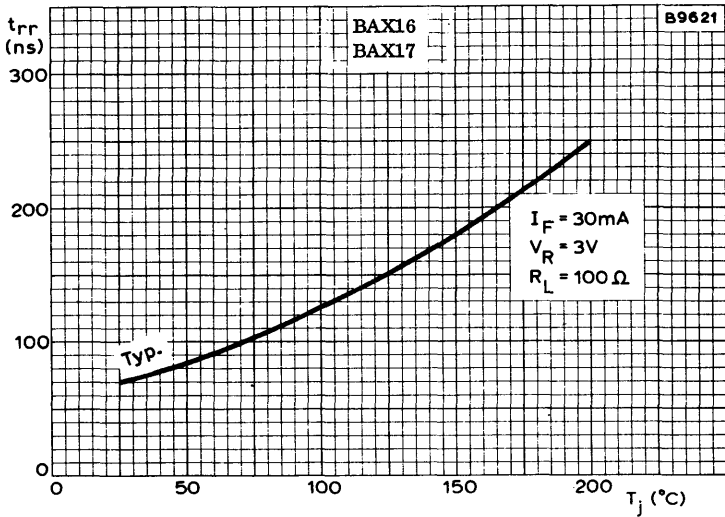
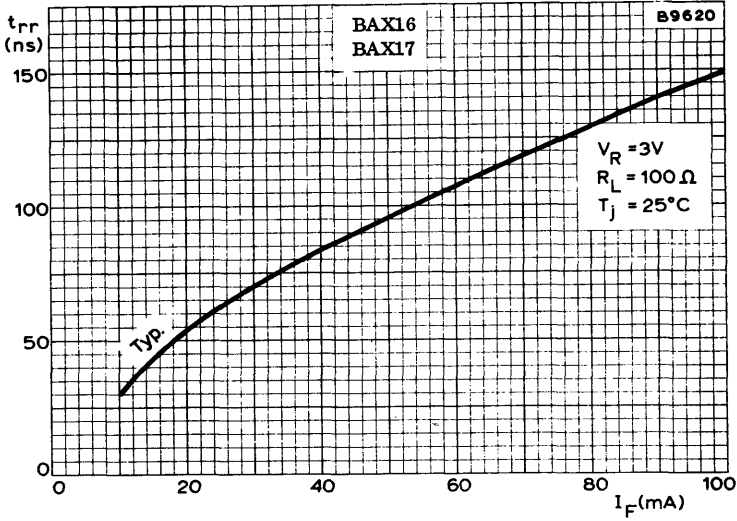

REVERSE RECOVERY TIME PLOTTED AGAINST FORWARD CURRENT
AND JUNCTION TEMPERATURE



SILICON DIODES

Silicon general purpose diodes in all-glass DO-35 envelopes.

QUICK REFERENCE DATA

		OA200	OA202	
Continuous reverse voltage	V_R max.	50	150	V
Repetitive peak forward current	I_{FRM} max.	250		mA
Thermal resistance from junction to ambient	$R_{th\ j-a}$ =	0,4		°C/mW
Forward voltage $I_F = 30\text{ mA}; T_{amb} = 25\text{ °C}$	V_F typ.	0,9		V
Reverse recovery time when switched from $I_F = 30\text{ mA}$ to $V_R = 35\text{ V};$ $R_L = 2,5\text{ k}\Omega;$ measured at $I_R = 4\text{ mA}$	t_{rr} typ.	3,5		μs

MECHANICAL DATA

Dimensions in mm

Fig. 1 SOD-27 (DO-35).

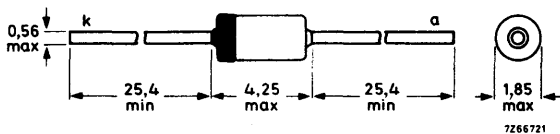

The diodes are type-branded; the cathode being indicated by a coloured band.

RATINGS

Limiting values in accordance with the Absolute Maximum System (IEC 134)

Continuous reverse voltage	OA200	V_R	max.	50	V
	OA202	V_R	max.	150	V
				$T_{amb} = 25\text{ }^\circ\text{C}$	$T_{amb} = 125\text{ }^\circ\text{C}$
Average rectified forward current (averaged over any 20 ms period)	$I_F(AV)$	max.	160	48	mA
Average forward current for sinusoidal operation	$I_F(AV)$	max.	80	40	mA
Forward current (d.c.; see page 4)	I_F	max.	160	48	mA
Repetitive peak forward current	I_{FRM}	max.	250	125	mA
Storage temperature	T_{stg}		-55 to + 125		$^\circ\text{C}$
Operating junction temperature	T_j	max.	150		$^\circ\text{C}$

THERMAL RESISTANCE

From junction to ambient in free air	$R_{th\ j-a}$	=	0,4	$^\circ\text{C}/\text{mW}$
--------------------------------------	---------------	---	-----	----------------------------

CHARACTERISTICS

				$T_{amb} = 25\text{ }^\circ\text{C}$	$T_{amb} = 125\text{ }^\circ\text{C}$	
Forward voltage $I_F = 0,1\text{ mA}$	V_F	typ.	0,52	-	V	
		<	0,62	0,30	V	
$I_F = 10\text{ mA}$	V_F	typ.	0,80	-	V	
		<	0,96	0,65	V	
$I_F = 30\text{ mA}$	V_F	typ.	0,90	-	V	
		<	1,15	0,80	V	
Reverse current $V_R = V_{Rmax}$	OA200	I_R	typ.	0,02	1	μA
			<	0,10	10	μA
	OA202	I_R	typ.	0,01	0,5	μA
			<	0,10	10	μA
Diode capacitance at $T_{amb} = 25\text{ }^\circ\text{C}$ $V_R = 0,75\text{ V}; f = 0,5\text{ MHz}$	C_d	typ.	10		pF	
		<	25		pF	

CHARACTERISTICS (continued)

$T_{amb} = 25\text{ }^{\circ}\text{C}$

Reverse recovery current when switched from

$I_F = 5\text{ mA}$ to $V_R = 5\text{ V}$; $R_L = 2,5\text{ k}\Omega$;

measured at $t_{rr} = 3,5\text{ }\mu\text{s}$

measured at $t_{rr} = 10\text{ }\mu\text{s}$

I_R typ. 1,2 mA
 I_R typ. 35 μA

Reverse recovery current when switched from

$I_F = 30\text{ mA}$ to $V_R = 35\text{ V}$; $R_L = 2,5\text{ k}\Omega$

measured at $t_{rr} = 3,5\text{ }\mu\text{s}$

measured at $t_{rr} = 10\text{ }\mu\text{s}$

I_R typ. 4 mA
 I_R typ. 230 μA

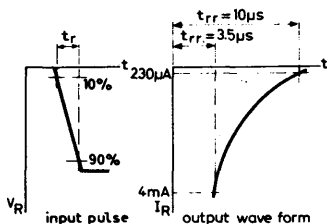

Fig. 2 Waveforms.

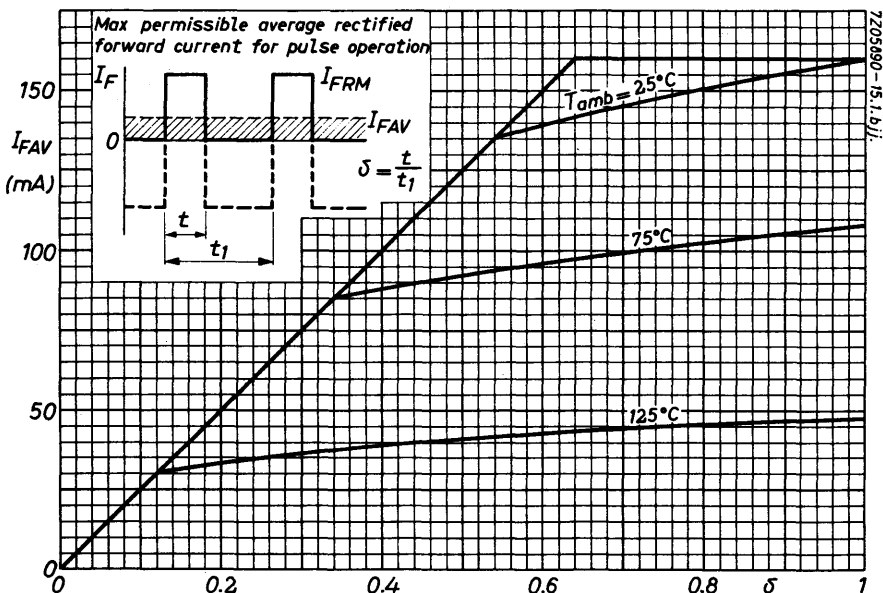

Fig. 3.



Fig. 5.

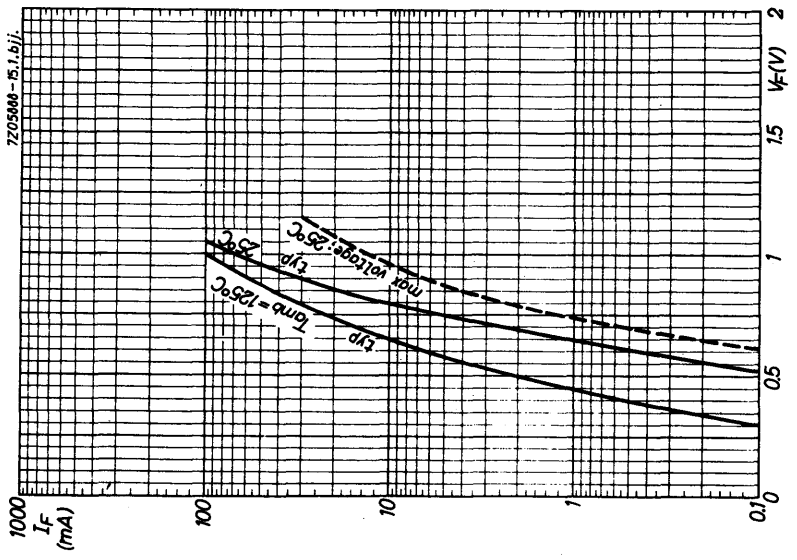

Fig. 4.

HIGH-SPEED SILICON DIODES



Planar epitaxial diodes intended for general purpose applications.

QUICK REFERENCE DATA

Continuous reverse voltage	V_R	max.	75 V
Repetitive peak reverse voltage	V_{RRM}	max.	100 V
Repetitive peak forward current	I_{FRM}	max.	225 mA
Forward voltage $I_F = 10 \text{ mA}$	V_F	<	1 V
Reverse recovery time when switched from $I_F = 10 \text{ mA}$ to $I_R = 60 \text{ mA}$; $R_L = 100 \Omega$; measured at $I_R = 1 \text{ mA}$	t_{rr}	<	4 ns

MECHANICAL DATA

Dimensions in mm

Fig. 1 SOD-27 (DO-35).

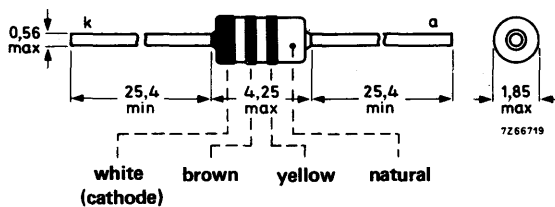

The diodes may be either type-branded or colour-coded.

Products approved to CECC 50 001-021 available on request.



Mullard

RATINGS Limiting values in accordance with the Absolute Maximum System (IEC 134)

Voltages

Continuous reverse voltage	V_R	max.	75	V
Repetitive peak reverse voltage	V_{RRM}	max.	100	V

Currents

Average rectified forward current (averaged over any 20 ms period)	$T_{amb} = 25\text{ }^\circ\text{C}$ $T_{amb} = 150\text{ }^\circ\text{C}$	$I_F(AV)$	max.	75	mA
		$I_F(AV)$	max.	10	mA
Forward current (d. c.)		I_F	max.	75	mA
Repetitive peak forward current		I_{FRM}	max.	225	mA
Non-repetitive peak forward current (t = 1 s)		I_{FSM}	max.	500	mA
Total power dissipation		P_{tot}	max.	250	mW

Temperatures

Storage temperature	T_{stg}	-65 to +200	$^\circ\text{C}$
Operating ambient temperature	T_{amb}	-65 to +175	$^\circ\text{C}$

CHARACTERISTICS

$T_j = 25\text{ }^\circ\text{C}$ unless otherwise specified

Forward voltages

$I_F = 10\text{ mA}$	V_F	<	1	V
----------------------	-------	---	---	---

Reverse avalanche breakdown voltage

$I_R = 100\text{ }\mu\text{A}$	$V_{(BR)R}$	>	100	V
--------------------------------	-------------	---	-----	---

Reverse currents

$V_R = 20\text{ V}$	I_R	<	25	nA
$V_R = 75\text{ V}$	I_R	<	5	μA
$V_R = 20\text{ V}; T_j = 150\text{ }^\circ\text{C}$	I_R	<	50	μA

Diode capacitance

$V_R = 0; f = 1\text{ MHz}$	C_d	<	4	pF
-----------------------------	-------	---	---	----

CHARACTERISTICS (continued)

$T_j = 25\text{ }^\circ\text{C}$

Forward recovery voltage when switched to

$I_F = 50\text{ mA}; t_r = 30\text{ ns}$

$V_{fr} < 2,5\text{ V}$

Test circuit and waveforms :

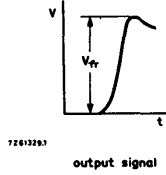
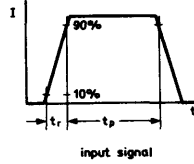
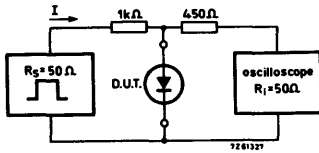

Input signal : Rise time of the forward pulse

$t_r = 20\text{ ns}$

Forward current pulse duration

$t_p = 120\text{ ns}$

Duty factor

$\delta = 0,01$

Oscilloscope : Rise time

$t_r = 0,35\text{ ns}$

Circuit capacitance $C \leq 1\text{ pF}$ ($C =$ oscilloscope input capacitance + parasitic capacitance)

Reverse recovery time when switched from

$I_F = 10\text{ mA}$ to $I_R = 10\text{ mA}; R_L = 100\ \Omega$; measured at $I_R = 1\text{ mA}$

$t_{rr} < 8\text{ ns}$

$I_F = 10\text{ mA}$ to $I_R = 60\text{ mA}; R_L = 100\ \Omega$; measured at $I_R = 1\text{ mA}$

$t_{rr} < 4\text{ ns}$

Test circuit and waveforms :

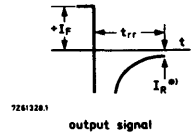
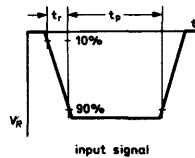
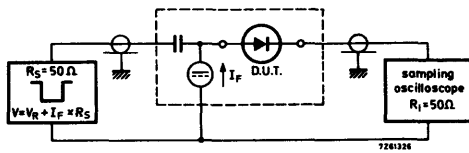

Input signal : Rise time of the reverse pulse

$t_r = 0,6\text{ ns}$

*) $I_R = 1\text{ mA}$

Reverse pulse duration

$t_p = 100\text{ ns}$

Duty factor

$\delta = 0,05$

Oscilloscope : Rise time

$t_r = 0,35\text{ ns}$

Circuit capacitance $C \leq 1\text{ pF}$ ($C =$ oscilloscope input capacitance + parasitic capacitance)

CHARACTERISTICS (continued)

$T_j = 25\text{ }^\circ\text{C}$

Rectifying efficiency

$$\eta = \frac{V_O}{V_{i(\text{rms})} \sqrt{2}}$$

$f = 100\text{ MHz}; V_{i(\text{rms})} = 2\text{ V}$

$\eta > 45\%$

Test circuit:

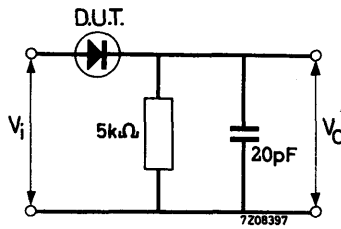

HIGH-SPEED SILICON DIODES



Planar epitaxial diodes intended for general purpose applications.

QUICK REFERENCE DATA

Continuous reverse voltage	V_R	max.	75 V
Repetitive peak reverse voltage	V_{RRM}	max.	100 V
Repetitive peak forward current	I_{FRM}	max.	225 mA
Forward voltage $I_F = 10 \text{ mA}$	V_F	<	1 V
Reverse recovery time when switched from $I_F = 10 \text{ mA}$ to $I_R = 60 \text{ mA}$; $R_L = 100 \Omega$; measured at $I_R = 1 \text{ mA}$	t_{rr}	<	4 ns

MECHANICAL DATA

Dimensions in mm

Fig. 1 SOD-27 (DO-35).

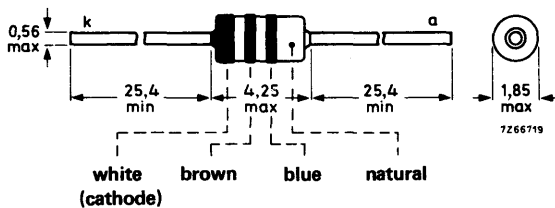

The diodes may be either type-branded or colour-coded.

RATINGS Limiting values in accordance with the Absolute Maximum System (IEC 134)

Voltages

Continuous reverse voltage	V_R	max.	75	V
Repetitive peak reverse voltage	V_{RRM}	max.	100	V

Currents

Average rectified forward current (averaged over any 20 ms period)	$T_{amb} = 25\text{ }^\circ\text{C}$ $T_{amb} = 150\text{ }^\circ\text{C}$	$I_F(AV)$ $I_F(AV)$	max. max.	75 10	mA mA
Forward current (d.c.)		I_F	max.	75	mA
Repetitive peak forward current		I_{FRM}	max.	225	mA
Non-repetitive peak forward current (t = 1 s)		I_{FSM}	max.	500	mA
Total power dissipation		P_{tot}	max.	250	mW

Temperatures

Storage temperature	T_{stg}	-65 to +200	$^\circ\text{C}$
Operating ambient temperature	T_{amb}	-65 to +175	$^\circ\text{C}$

CHARACTERISTICS

$T_j = 25\text{ }^\circ\text{C}$ unless otherwise specified

Forward voltages

$I_F = 10\text{ mA}$	V_F	<	1	V
----------------------	-------	---	---	---

Reverse avalanche breakdown voltage

$I_R = 100\text{ }\mu\text{A}$	$V_{(BR)R}$	>	100	V
--------------------------------	-------------	---	-----	---

Reverse currents

$V_R = 20\text{ V}$	I_R	<	25	nA
$V_R = 75\text{ V}$	I_R	<	5	μA
$V_R = 20\text{ V}; T_j = 150\text{ }^\circ\text{C}$	I_R	<	50	μA

Diode capacitance

$V_R = 0; f = 1\text{ MHz}$	C_d	<	2	pF
-----------------------------	-------	---	---	----

CHARACTERISTICS (continued)

$T_j = 25\text{ }^\circ\text{C}$

Forward recovery voltage when switched to

$I_F = 50\text{ mA}; t_r = 20\text{ ns}$

$V_{fr} < 2,5\text{ V}$

Test circuit and waveforms :

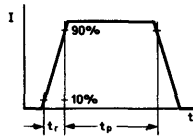
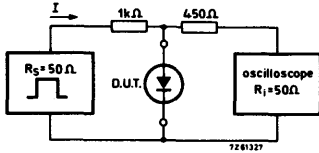

input signal

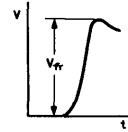

output signal

Input signal : Rise time of the forward pulse
 Forward current pulse duration
 Duty factor

$t_r = 20\text{ ns}$
 $t_p = 120\text{ ns}$
 $\delta = 0,01$

Oscilloscope : Rise time

$t_r = 0,35\text{ ns}$

Circuit capacitance $C \leq 1\text{ pF}$ ($C =$ oscilloscope input capacitance + parasitic capacitance)

Reverse recovery time when switched from

$I_F = 10\text{ mA}$ to $I_R = 60\text{ mA}; R_L = 100\text{ }\Omega$;
 measured at $I_R = 1\text{ mA}$

$t_{rr} < 4\text{ ns}$

Test circuit and waveforms :

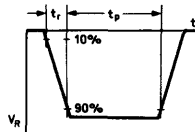
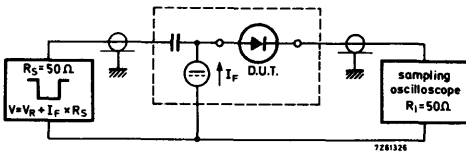

input signal

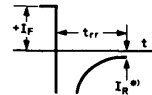

7261328.1

output signal

Input signal : Rise time of the reverse pulse
 Reverse pulse duration
 Duty factor

$t_r = 0,6\text{ ns}$
 $t_p = 100\text{ ns}$
 $\delta = 0,05$

*) $I_R = 1\text{ mA}$

Oscilloscope : Rise time

$t_r = 0,35\text{ ns}$

Circuit capacitance $C \leq 1\text{ pF}$ ($C =$ oscilloscope input capacitance + parasitic capacitance)

CHARACTERISTICS (continued)

$T_j = 25\text{ }^\circ\text{C}$

Rectifying efficiency

$$\eta = \frac{V_O}{V_{i(\text{rms})} \sqrt{2}}$$

$f = 100\text{ MHz}; V_{i(\text{rms})} = 2\text{ V}$

$\eta > 45\%$

Test circuit:

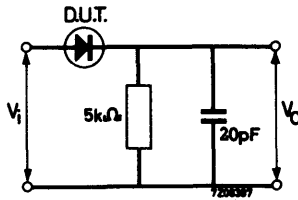



HIGH-SPEED SILICON DIODES

Whiskerless diodes in subminiature DO-35 envelopes.
These diodes are primarily intended for fast logic applications.

QUICK REFERENCE DATA

Continuous reverse voltage	V_R	max.	75 V
Repetitive peak reverse voltage	V_{RRM}	max.	75 V
Repetitive peak forward current	I_{FRM}	max.	450 mA
Forward voltage			
1N4148: $I_F = 10$ mA	V_F	<	1 V
1N4446: $I_F = 20$ mA			
1N4448: $I_F = 100$ mA			
Reverse recovery time when switched from $I_F = 10$ mA to $I_R = 60$ mA; $R_L = 100 \Omega$; measured at $I_R = 1$ mA	t_{rr}	<	4 ns

MECHANICAL DATA

Dimensions in mm

Fig. 1 SOD-27 (DO-35).

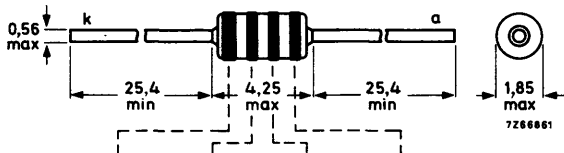

1N4148:	yellow	brown	yellow	grey
1N4446:	yellow	yellow	yellow	blue
1N4448:	yellow	yellow	yellow	grey

(cathode)

The diodes may be either type-branded or colour-coded.

Products, available to CECC 50 001-021, available on request.



1N4148
1N4446
1N4448

RATINGS

Limiting values in accordance with the Absolute Maximum System (IEC 134)

Continuous reverse voltage	V_R	max.	75 V
Repetitive peak reverse voltage	V_{RRM}	max.	75 V
Average rectified forward current	$I_{F(AV)}$	max.	150 mA
Forward current (d.c.)	I_F	max.	200 mA
Repetitive peak forward current	I_{FRM}	max.	450 mA
Non-repetitive peak forward current			
$t = 1 \mu s$	I_{FSM}	max.	2000 mA
$t = 1 s$	I_{FSM}	max.	500 mA
Total power dissipation up to $T_{amb} = 25 \text{ }^\circ\text{C}$	P_{tot}	max.	500 mW
Derating factor			2,85 mW/ $^\circ\text{C}$
Storage temperature	T_{stg}		-65 to +200 $^\circ\text{C}$
Junction temperature	T_j	max.	200 $^\circ\text{C}$

CHARACTERISTICS

$T_j = 25 \text{ }^\circ\text{C}$ unless otherwise specified

Forward voltages

1N4148: $I_F = 10 \text{ mA}$

1N4446: $I_F = 20 \text{ mA}$

1N4448: $I_F = 100 \text{ mA}$

1N4448: $I_F = 5 \text{ mA}$

$V_F < 1 \text{ V}$

$V_F 0,62 \text{ to } 0,72 \text{ V}$

Reverse avalanche breakdown voltage

$I_R = 100 \mu\text{A}$

$I_R = 5 \mu\text{A}$

$V_{(BR)R} > 100 \text{ V}$

$V_{(BR)R} > 75 \text{ V}$

Reverse currents

$V_R = 20 \text{ V}$

$V_R = 20 \text{ V}; T_j = 100 \text{ }^\circ\text{C}$

$V_R = 20 \text{ V}; T_j = 150 \text{ }^\circ\text{C}$

$I_R < 25 \text{ nA}$

1N4448 $I_R < 3 \mu\text{A}$

$I_R < 50 \mu\text{A}$

Diode capacitance

$V_R = 0; f = 1 \text{ MHz}$

$C_d < 4 \text{ pF}$

CHARACTERISTICS (continued)

$T_j = 25\text{ }^\circ\text{C}$

Forward recovery voltage when switched to

$I_F = 50\text{ mA}; t_r = 20\text{ ns}$

$V_{fr} < 2,5\text{ V}$

Test circuit and waveforms :

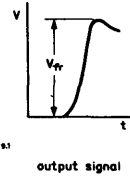
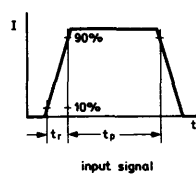
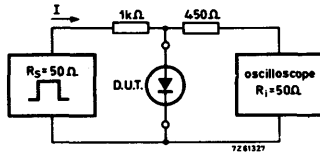

Input signal : Rise time of the forward pulse

$t_r = 20\text{ ns}$

Forward current pulse duration

$t_p = 120\text{ ns}$

Duty factor

$\delta = 0,01$

Oscilloscope : Rise time

$t_r = 0,35\text{ ns}$

Circuit capacitance $C \leq 1\text{ pF}$ ($C =$ oscilloscope input capacitance + parasitic capacitance)

Reverse recovery time when switched from

$I_F = 10\text{ mA}$ to $I_R = 60\text{ mA}; R_L = 100\text{ }\Omega$;

measured at $I_R = 1\text{ mA}$

$t_{rr} < 4\text{ ns}$

Test circuit and waveforms :

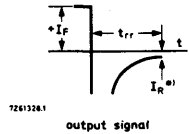
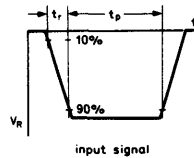
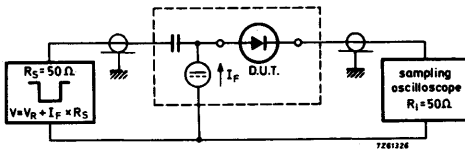

Input signal : Rise time of the reverse pulse

$t_r = 0,6\text{ ns}$

*) $I_R = 1\text{ mA}$

Reverse pulse duration

$t_p = 100\text{ ns}$

Duty factor

$\delta = 0,05$

Oscilloscope : Rise time

$t_r = 0,35\text{ ns}$

Circuit capacitance $C \leq 1\text{ pF}$ ($C =$ oscilloscope input capacitance + parasitic capacitance)

VOLTAGE REGULATOR DIODES

(Low power)





LOW VOLTAGE STABISTOR



Silicon planar epitaxial diode in DO-35 envelope. This diode is intended for low voltage stabilizing e.g. bias stabilizer in class-B output stages, clipping, clamping and meter protection.

QUICK REFERENCE DATA

Repetitive peak forward current	I_{FRM}	max.	250 mA
Storage temperature	T_{stg}		-65 to + 200 °C
Junction temperature	T_j	max.	200 °C
Thermal resistance from junction to ambient	$R_{th j-a}$	=	0,38 °C/mW
Forward voltage	V_F		
$I_F = 0,1$ mA	V_F		610 to 690 mV
$I_F = 1,0$ mA	V_F		680 to 760 mV
$I_F = 10$ mA	V_F		750 to 830 mV
$I_F = 100$ mA	V_F		870 to 960 mV
Diode capacitance	C_d	<	140 pF
$V_R = 0$; $f = 1$ MHz			

MECHANICAL DATA

Dimensions in mm

DO-35.

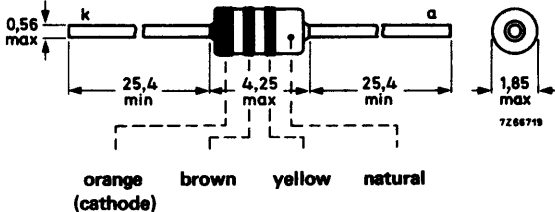

The diodes may be either type-branded or colour coded.

Products approved to CECC 50 001-026 available on request



RATINGS

Limiting values in accordance with the Absolute Maximum System (IEC 134)

Repetitive peak forward current	I_{FRM}	max.	250 mA
Storage temperature	T_{stg}	-65 to + 200	°C
Junction temperature	T_j	max.	200 °C

THERMAL RESISTANCE

From junction to ambient in free air	$R_{th\ j-a}$	=	0,38 °C/mW
--------------------------------------	---------------	---	------------

CHARACTERISTICS

 $T_j = 25\text{ °C}$ unless otherwise specified

Forward voltage

$I_F = 0,1\text{ mA}$	V_F	610 to 690	mV
$I_F = 1,0\text{ mA}$	V_F	680 to 760	mV
$I_F = 5,0\text{ mA}$	V_F	730 to 810	mV
$I_F = 10\text{ mA}$	V_F	750 to 830	mV
$I_F = 100\text{ mA}$	V_F	870 to 960	mV

Reverse current

$V_R = 4\text{ V}$	I_R	<	5 μA
--------------------	-------	---	-----------------

Temperature coefficient

$I_F = 1\text{ mA}$	S_F	typ.	-1,8 mV/°C
---------------------	-------	------	------------

Differential resistance at $f = 1\text{ kHz}$

$I_F = 1\text{ mA}$	r_{diff}	typ.	30 Ω
$I_F = 10\text{ mA}$	r_{diff}	typ.	3,5 Ω
		<	6,0 Ω

Diode capacitance

$V_R = 0; f = 1\text{ MHz}$	C_d	<	140 pF
-----------------------------	-------	---	--------

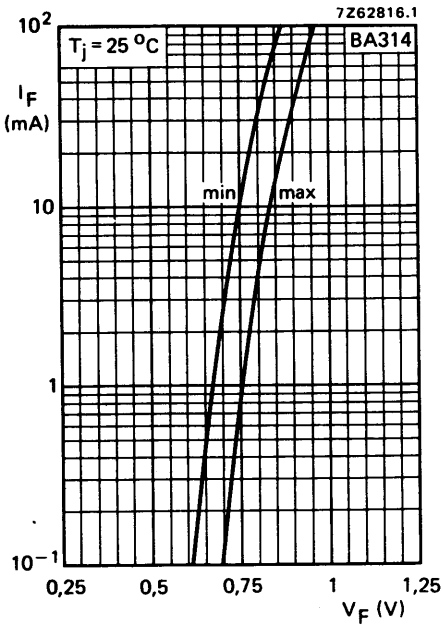

LOW VOLTAGE STABISTORS

Silicon planar integrated voltage regulator diodes, intended for low power clipping, level shifting, voltage regulation and temperature stabilization of transistor base-emitter biasing network. The stabistors operate in the forward mode thus the cathode must be adjacent to the negative connection.

QUICK REFERENCE DATA

	BZV46-1V5		2V0	
	Regulation voltage ranges	V_F	> 1,35 < 1,55	2,00 2,30
Continuous reverse voltage	V_R	max. 4	4	V
Repetitive peak forward current	I_{FRM}	max. 120	80	mA
Total power dissipation up to $T_{amb} = 55\text{ }^\circ\text{C}$	P_{tot}	max. 250	250	mW
Differential resistance $I_F = 5\text{ mA}; f = 1\text{ kHz}$	r_{diff}	< 20	30	Ω

MECHANICAL DATA

Dimensions in mm

Fig. 1 SOD-27 (DO-35).

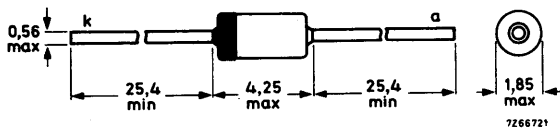

Cathode indicated by coloured end.
The diodes are type-branded

BZV46-1V5
BZV46-2V0

RATINGS

Limiting values in accordance with the Absolute Maximum System (IEC 134)

	BZV46-1V5	2V0	
Continuous reverse voltage	V_R max.	4	4 V
Repetitive peak reverse voltage	V_{RRM} max.	4	4 V
Repetitive peak forward current	I_{FRM} max.	120	80 mA
Total power dissipation up to $T_{amb} = 55^\circ C$	P_{tot} max.	250 mW	
Storage temperature	T_{stg}	-65 to + 150 °C	
Junction temperature	T_j max.	150 °C	

THERMAL RESISTANCE

From junction to ambient in free air

see Fig. 2

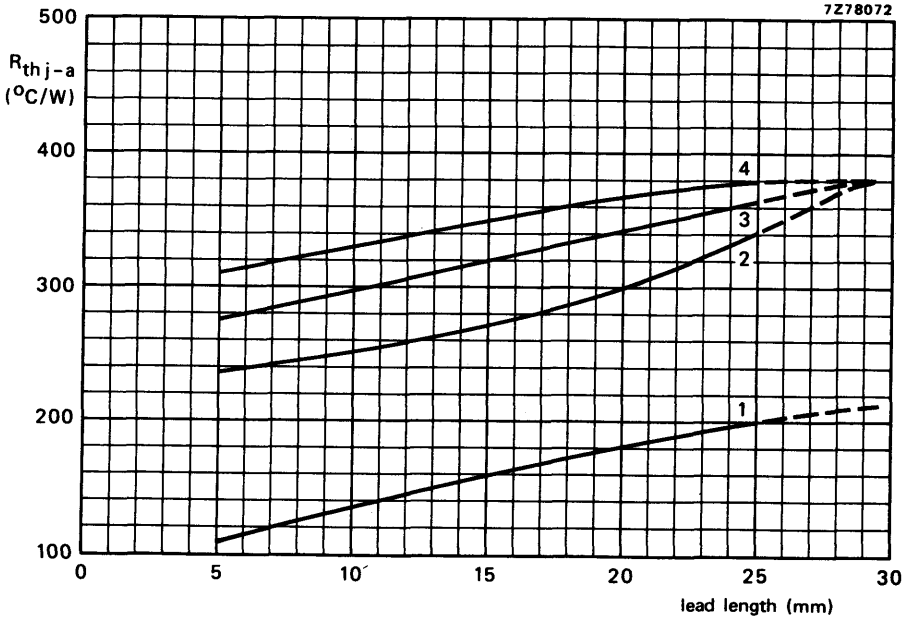

Fig. 2 Thermal resistance as a function of the lead length for various mounting.

curve	mounting
1	Infinite heatsink at end of lead.
2	Typical printed-circuit board with large area of copper (> 100 mm ²).
3	Tag mounting.
4	Typical printed-circuit board with small area of copper (< 50 mm ²).

CHARACTERISTICS

$T_j = 25\text{ }^\circ\text{C}$ unless otherwise specified

Regulation voltage ranges

$I_F = 5\text{ mA}$

Temperature coefficient at $I_F = 5\text{ mA}$

Differential resistance at $f = 1\text{ kHz}$; $I_F = 5\text{ mA}$

Reverse current

$V_R = 4\text{ V}$

	BZV46-1V5	2V0
V_F	$> 1,35$ $< 1,55$	$2,00\text{ V}$ $2,30\text{ V}$
S_F	typ. $-3,65$	$-5,60\text{ mV}/^\circ\text{C}$
r_{diff}	< 20	$30\ \Omega$
I_R	< 500	500 nA

7282482

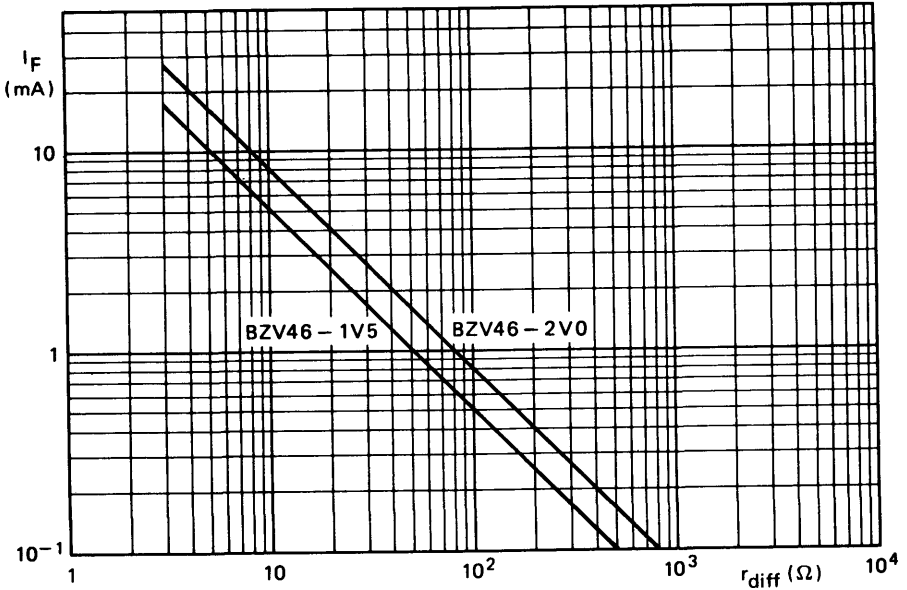

Fig. 3 Typical values; $T_j = 25\text{ }^\circ\text{C}$.

BZV46-1V5
BZV46-2V0

7Z82483

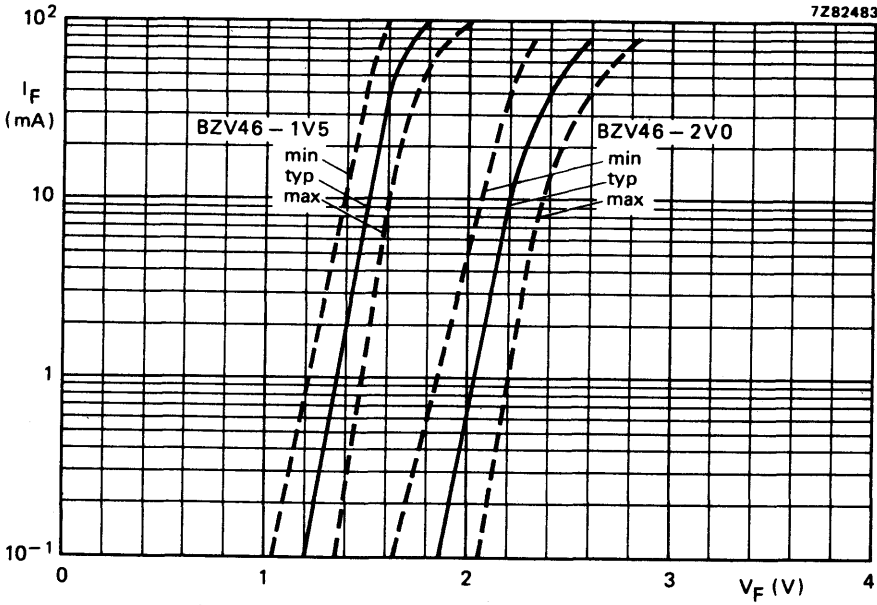

Fig. 4 Regulation characteristics at $T_j = 25\text{ }^\circ\text{C}$.

VOLTAGE REGULATOR DIODES

Silicon planar voltage regulator diodes in hermetically sealed DO-41 glass envelopes intended for stabilization purposes. The series covers the normalized E24 ($\pm 5\%$) range of nominal working voltages ranging from 5,1 V to 75 V.

QUICK REFERENCE DATA

Working voltage range	V_Z	nom.	5,1 to 75 V
Total power dissipation	P_{tot}	max.	1,3 W*
Non-repetitive peak reverse power dissipation $t_p = 100 \mu s; T_j = 25 \text{ }^\circ\text{C}$	P_{ZSM}	max.	60 W
Junction temperature	T_j	max.	200 $^\circ\text{C}$
Thermal resistance from junction to tie-point	$R_{th j-tp}$	=	110 $^\circ\text{C/W}^*$

* If leads are kept at $T_{tp} = 55 \text{ }^\circ\text{C}$ at 4 mm from body.

MECHANICAL DATA

Dimensions in mm

Fig. 1 DO-41 (SOD-66).

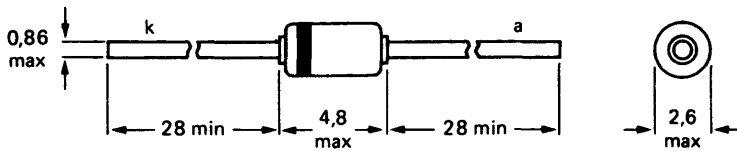

7278729.1

Cathode indicated by coloured band.

The diodes are type-branded

BZV85 SERIES

RATINGS

Limiting values in accordance with the Absolute Maximum System (IEC 134)

Working current (d.c.)	I_Z	limited by $P_{tot\ max}$
Non-repetitive peak reverse current $t_p = 10\ ms$; half sine-wave; $T_{amb} = 25\ ^\circ C$	I_{ZSM}	see table below
Repetitive peak forward current	I_{FRM}	max. 250 mA
		max. 1,30 W*
Total power dissipation (see also Fig. 2)	P_{tot}	max. 1 W**
Non-repetitive peak reverse power dissipation $t_p = 100\ \mu s$; $T_j = 25\ ^\circ C$	P_{ZSM}	max. 60 W
Storage temperature	T_{stg}	-65 to +200 °C
Junction temperature	T_j	max. 200 °C
THERMAL RESISTANCE		
From junction to tie-point	$R_{th\ j-tp}$	= 110 °C/W*
From junction to ambient mounted on a printed-circuit board	$R_{th\ j-a}$	= 175 °C/W**

BZV85-...	Non-repetitive peak reverse current
	I_{ZSM} (mA) max.
C5V1	1750
C5V6	1700
C6V2	1620
C6V8	1550
C7V5	1500
C8V2	1400
C9V1	1340
C10	1200
C11	1100
C12	1000
C13	900
C15	760
C16	700
C18	600
C20	540

BZV85-...	Non-repetitive peak reverse current
	I_{ZSM} (mA) max.
C22	500
C24	450
C27	400
C30	380
C33	350
C36	320
C39	296
C43	270
C47	246
C51	226
C56	208
C62	186
C68	171
C75	161

* If the temperature of the leads at 4 mm from the body are kept up to $T_{tp} = 55\ ^\circ C$.

** Measured in still air up to $T_{amb} = 25\ ^\circ C$ and mounted on printed-circuit board with lead length of 10 mm and print copper area of 1 cm² per lead.



CHARACTERISTICS

 $T_j = 25\text{ }^\circ\text{C}$ Forward voltage at $I_F = 50\text{ mA}$ $V_F < 1,0\text{ V}$

BZV85—	working voltage E24 ($\pm 5\%$) V_Z (V) at I_{Ztest}			test current I_{Ztest} (mA)	differential resistance r_{diff} (Ω) at I_{Ztest}	temperature coefficient S_Z (mV/ $^\circ\text{C}$) at I_{Ztest}		reverse current I_R (nA) at V_R	test voltage V_R (V)
	min.	nom.	max.			min.	max.		
C5V1	4,8	5,1	5,4	45	10	-0,5	2,2	3000	2,0
C5V6	5,2	5,6	6,0	45	7	0	2,7	2000	2,0
C6V2	5,8	6,2	6,6	35	4	0,6	3,6	2000	3,0
C6V8	6,4	6,8	7,2	35	3,5	1,3	4,3	2000	4,0
C7V5	7,0	7,5	7,9	35	3	2,5	5,5	1000	4,5
C8V2	7,7	8,2	8,7	25	5	3,1	6,1	700	5,0
C9V1	8,5	9,1	9,6	25	5	3,8	7,2	700	6,5
C10	9,4	10	10,6	25	8	4,7	8,5	200	7,0
C11	10,4	11	11,6	20	10	5,3	9,3	200	7,7
C12	11,4	12	12,7	20	10	6,3	10,8	200	8,4
C13	12,4	13	14,1	20	10	7,4	12,0	200	9,1
C15	13,8	15	15,6	15	15	8,9	13,6	50	10,5
C16	15,3	16	17,1	15	15	10,7	15,4	50	11,0
C18	16,8	18	19,1	15	20	11,8	17,1	50	12,5
C20	18,8	20	21,2	10	24	13,6	19,1	50	14,0
C22	20,8	22	23,3	10	25	16,6	22,1	50	15,5
C24	22,8	24	25,6	10	30	18,3	24,3	50	17
C27	25,1	27	28,9	8	40	20,1	27,5	50	19
C30	28	30	32	8	45	22,4	32,0	50	21
C33	31	33	35	8	45	24,8	35,0	50	23
C36	34	36	38	8	50	27,2	39,9	50	25
C39	37	39	41	6	60	29,6	43,0	50	27
C43	40	43	46	6	75	34,0	48,3	50	30
C47	44	47	50	4	100	37,4	52,5	50	33
C51	48	51	54	4	125	40,8	56,5	50	36
C56	52	56	60	4	150	46,8	63,0	50	39
C62	58	62	66	4	175	52,2	72,5	50	43
C68	64	68	72	4	200	60,5	81,0	50	48
C75	70	75	80	4	225	66,5	88,0	50	53



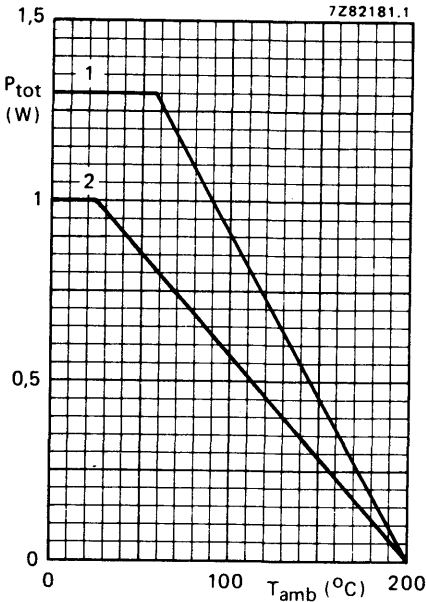

Fig. 2 Maximum permissible power dissipation versus ambient temperature.

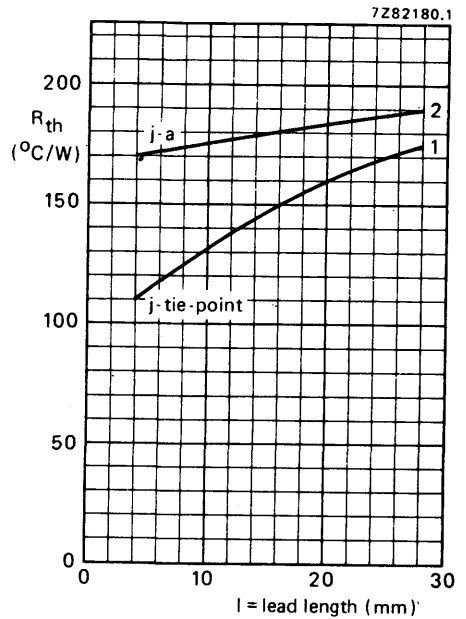

Fig. 3 Thermal resistance versus lead length.

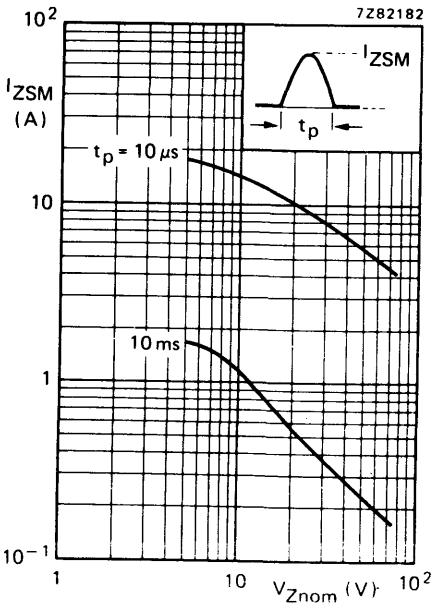

Fig. 4 Half sine-wave; $T_{amb} = 25^{\circ}C$.

Mounting methods (see Figs 2 and 3)

1. To tie-points (lead length = 4 mm in Fig. 2).
2. Mounted on a printed-circuit board (with lead length of 10 mm in Fig. 2) and print copper area of 1 cm^2 per lead.



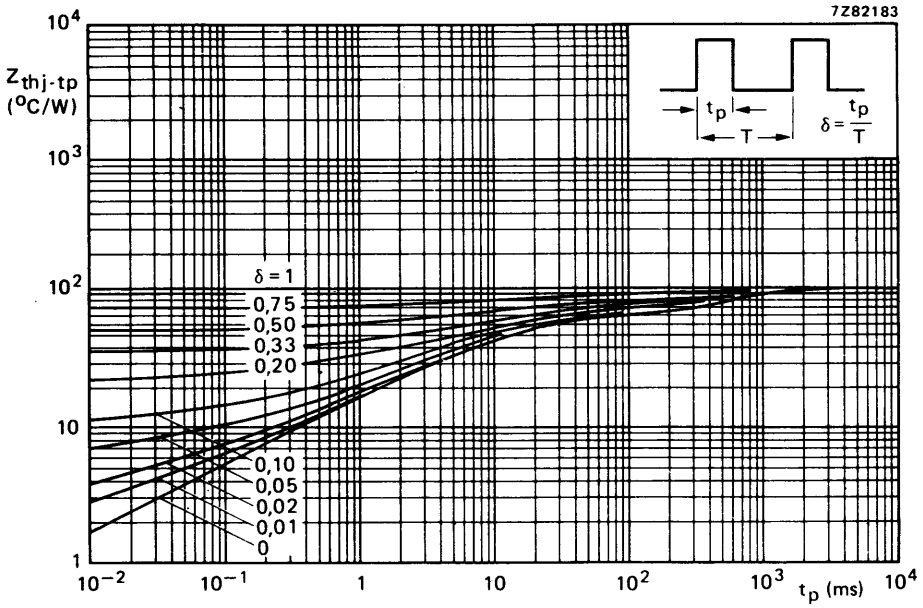

Fig. 5 Thermal impedance from junction to tie-point with a lead length of 4 mm.



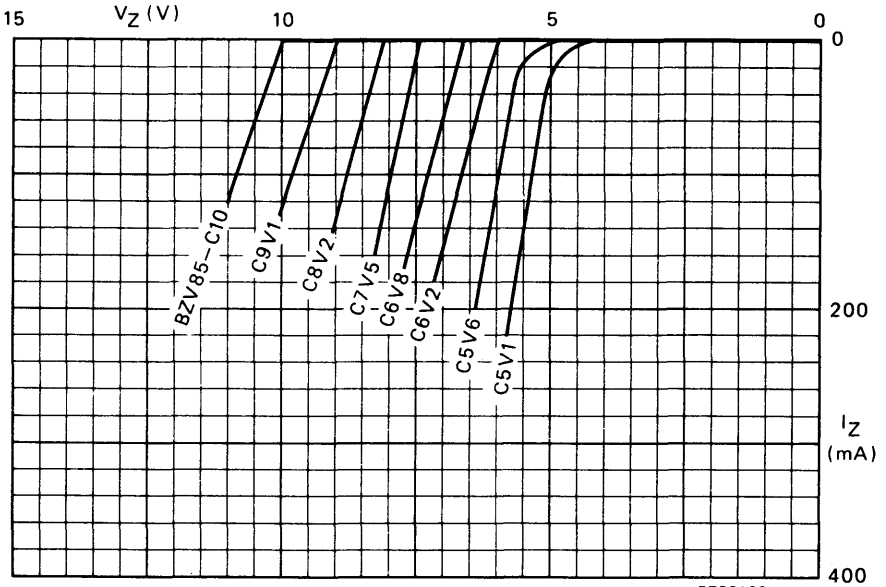

Fig. 6 Static characteristics; typical values; $T_{amb} = 25^\circ C$.

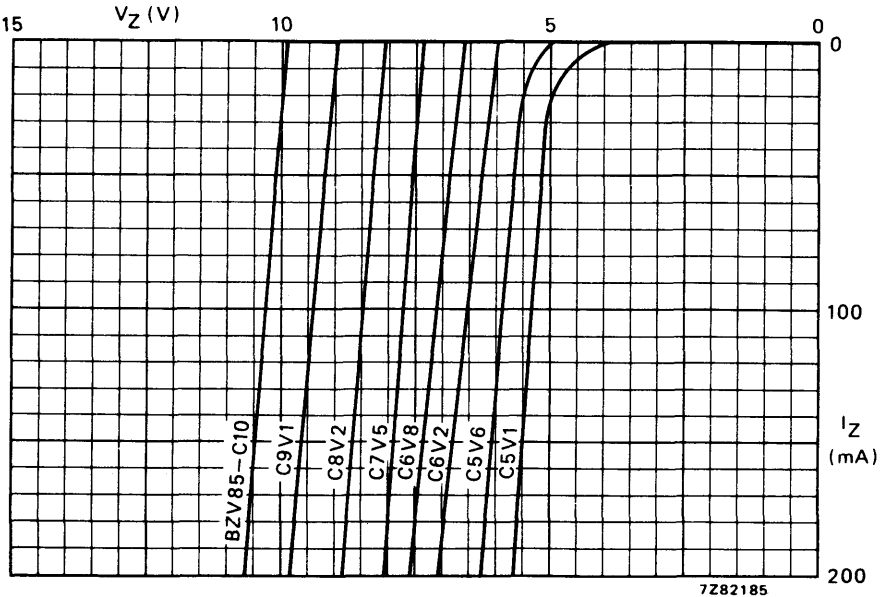

Fig. 7 Dynamic characteristics; typical values; $T_j = 25^\circ C$.



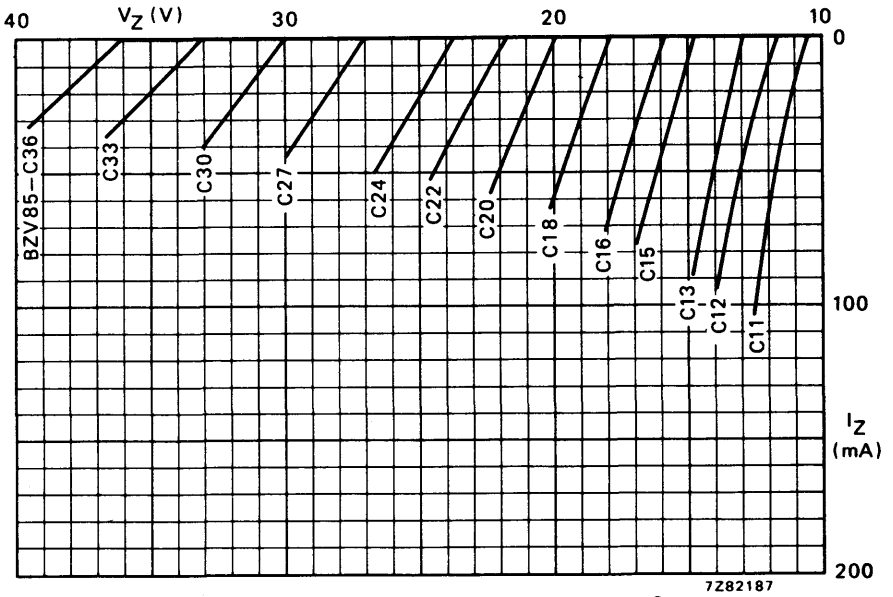

Fig. 8 Static characteristics; typical values; $T_{amb} = 25\text{ }^{\circ}\text{C}$.

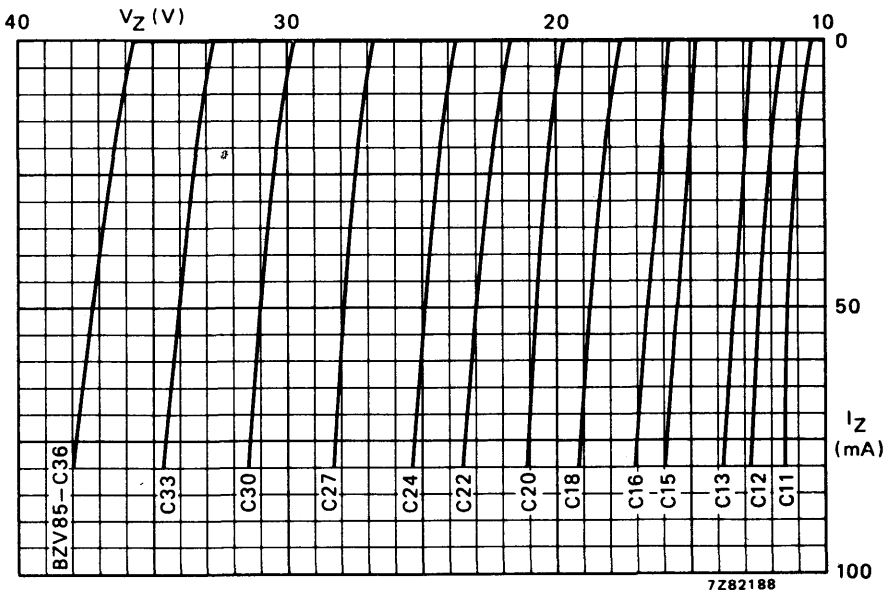

Fig. 9 Dynamic characteristics; typical values; $T_j = 25\text{ }^{\circ}\text{C}$.



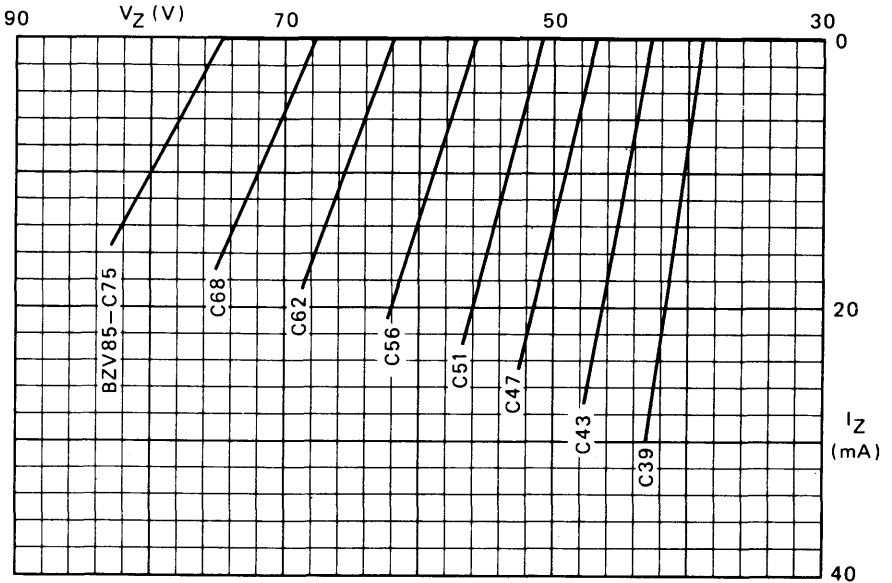

Fig. 10 Static characteristics; typical values; $T_{amb} = 25^\circ C$.

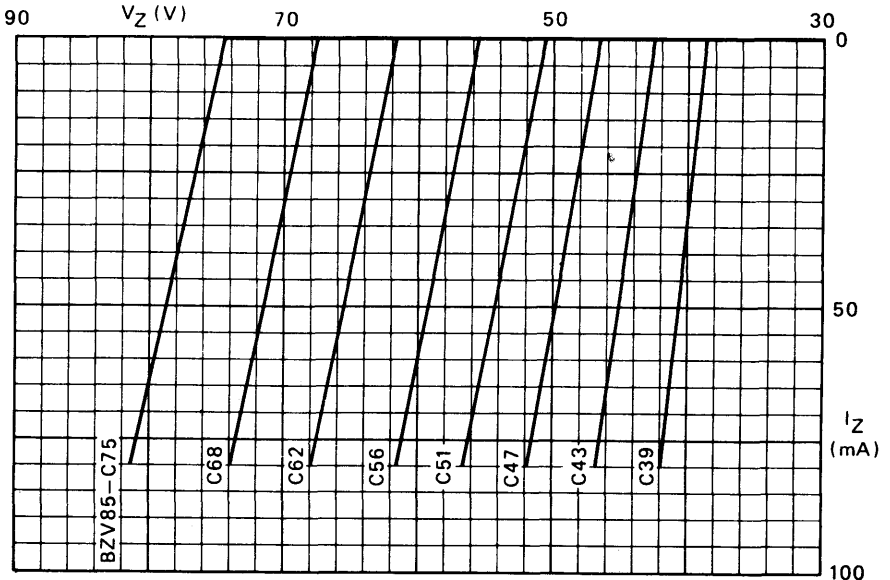

Fig. 11 Dynamic characteristics; typical values; $T_j = 25^\circ C$.



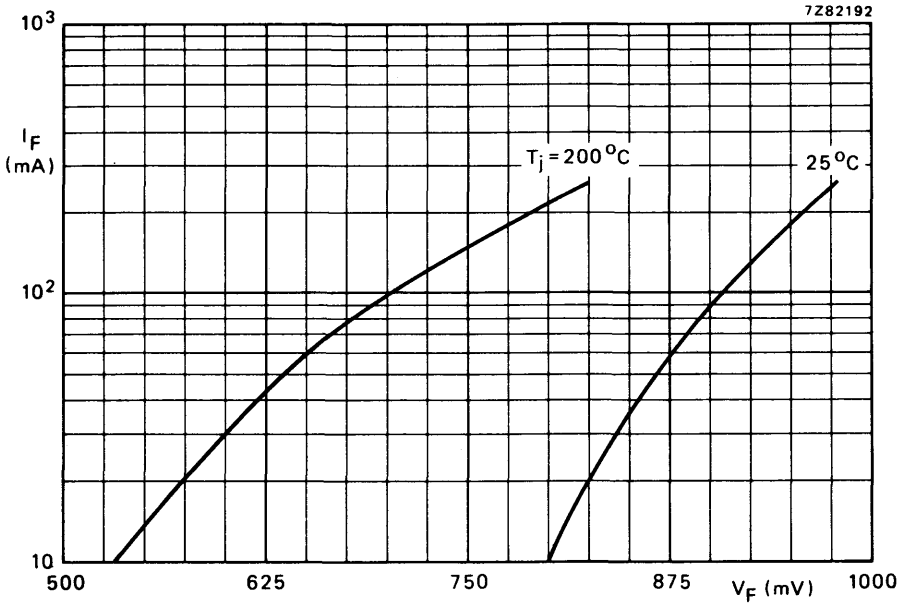

Fig. 12 Typical values.

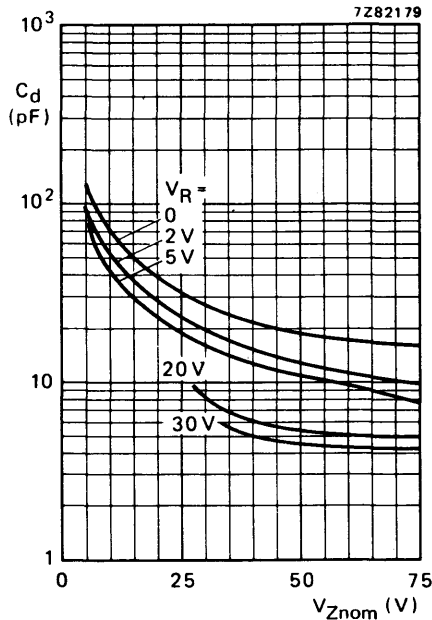

Fig. 13 $f = 1$ MHz; $T_j = 25^\circ\text{C}$; typical values.



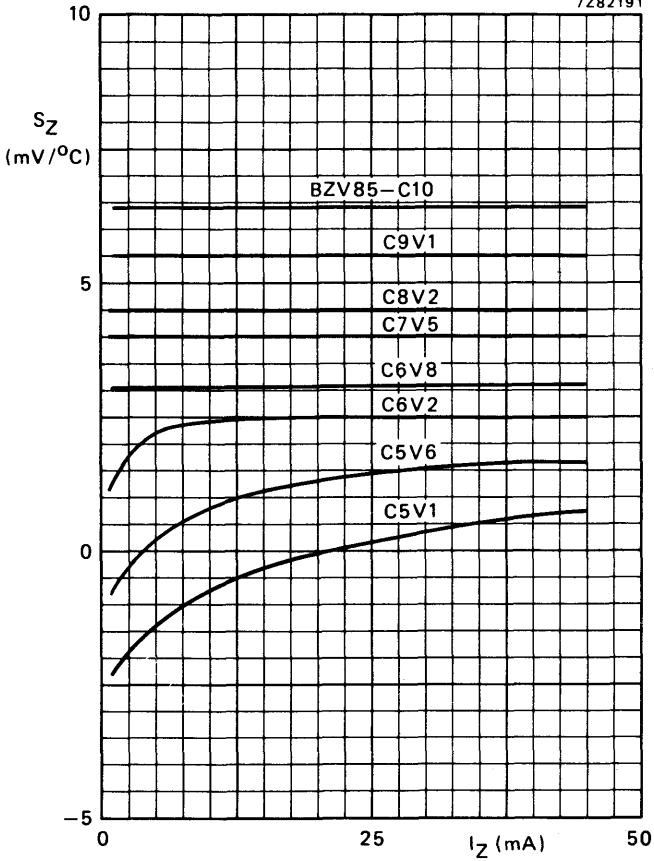

Fig. 14 $T_j = 25\text{ }^\circ\text{C}$ to $150\text{ }^\circ\text{C}$; typical values.

For types above 7,5 V the temperature coefficient is independent of current and can be read from the table on page 3.



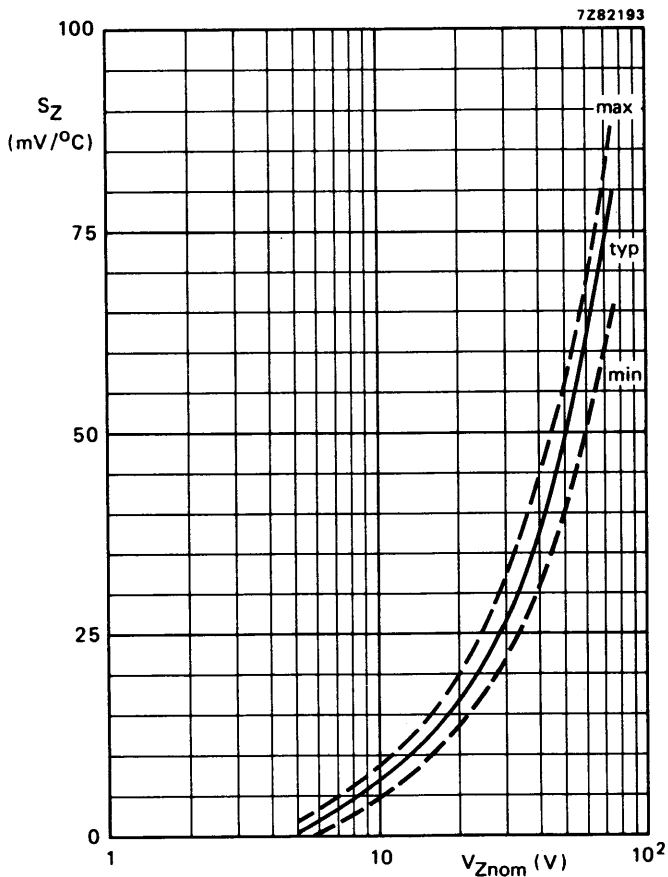

Fig. 15 $I_Z = I_{Ztest}$; $T_j = 25\text{ }^\circ\text{C}$ to $150\text{ }^\circ\text{C}$.



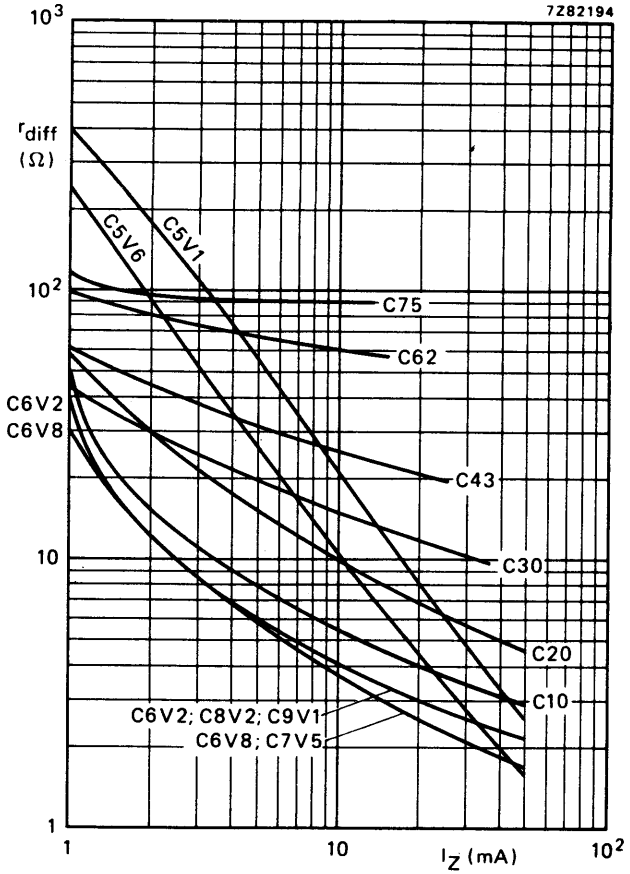

Fig. 16 $f = 1$ kHz; $T_j = 25$ °C; typical values.



VOLTAGE REGULATOR DIODES

Plastic encapsulated silicon diodes intended for general purpose use as medium power voltage regulators. They are suitable for use as transient suppressor diodes.

QUICK REFERENCE DATA

Working voltage range (5 PERCENT, Ref. B.S. 3494, appendix C)	V_Z	nom.	7.5 to 200 V
Total power dissipation; $T_{amb} \leq 25^\circ C$ BZX61—C7V5 to C130 BZX61—C150 to C200	P_{tot}	max.	1.3 W
	P_{tot}	max.	1.0 W
Repetitive peak reverse power dissipation	P_{ZRM}	max.	6 W
Non-repetitive peak reverse power dissipation $t = 100 \mu s$; $T_{amb} = 25^\circ C$	P_{ZSM}	max.	300 W

MECHANICAL DATA

Dimensions in mm

Fig.1 DO-15; the diodes are type branded

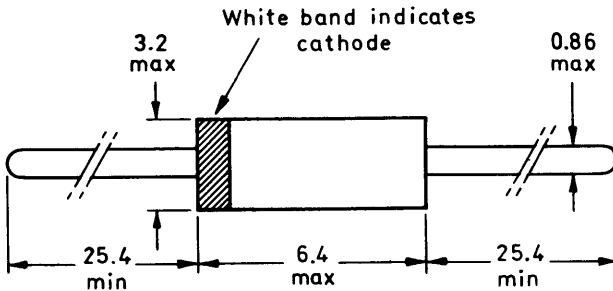

D 2523b

For operation as a voltage regulator diode the positive voltage is connected to the lead adjacent to the white band.

Available for current production only; for new designs, successors BZV85 are recommended.

The sealing of this plastic envelope fulfils the accelerated damp heat test, according to I.E.C. recommendation 68-2 (test D, severity IV, 6 cycles).



RATINGS

Limiting values of operation in accordance with the Absolute Maximum System (IEC134)

	Repetitive peak forward current	I_{FRM}	max.	1	A
→	Total power dissipation up to $T_{amb} = 25\text{ }^{\circ}\text{C}$	P_{tot}	max.	1.3	W
	BZX61-C7V5 to C130	P_{tot}	max.	1.0	W
	BZX61-C150 to C200				
	Repetitive peak reverse power dissipation	P_{ZRM}	max.	6	W
	Non-repetitive peak reverse power dissipation	P_{ZSM}	max.	300	W
	$t = 100\text{ }\mu\text{s}; T_{amb} = -55\text{ to }+25\text{ }^{\circ}\text{C}$				
	Storage temperature	T_{stg}		-65 to +175	$^{\circ}\text{C}$
→	Junction temperature	T_j	max.	175	$^{\circ}\text{C}$
	BZX61-C7V5 to C130	T_j	max.	150	$^{\circ}\text{C}$
	BZX61-C150 to C200				

THERMAL RESISTANCE

see pages 6, 8

→ CHARACTERISTICS

$T_j = 25\text{ }^{\circ}\text{C}$

Forward voltage

$I_F = 100\text{ mA}$

$V_F < 1.1\text{ V}$

BZX61-...	working voltage			differential resistance	temperature coefficient	reverse current		clamping voltage at $t_p = 1\text{ ms}; 80\text{ W}$ $V_{CL(R)}$ (V)
	V_Z (V)					r_{diff} (Ω)	S_Z (%/ $^{\circ}\text{C}$)	
	at $I_{Ztest} = 20\text{ mA}$			at $I_{Ztest} = 20\text{ mA}$	at $I_{Ztest} = 20\text{ mA}$	max.		typ.
	min.	nom.	max.	max.	typ.			
C7V5	7.0	7.5	7.9	5.0	+0.04	5	3	9.9
C8V2	7.7	8.2	8.7	7.5	+0.04	5	3	10.9
C9V1	8.5	9.1	9.6	8.0	+0.05	5	5	12.0
C10	9.4	10	10.6	8.5	+0.05	5	7	13.3
C11	10.4	11	11.6	9.0	+0.05	5	7	14.5
C12	11.4	12	12.7	9.0	+0.05	5	8	15.9
C13	12.4	13	14.1	10	+0.05	5	9	17.6
C15	13.8	15	15.6	14	+0.06	5	10	19.5



CHARACTERISTICS (continued)

 $T_j = 25^\circ\text{C}$

BZX61...	working voltage			differential resistance	temperature coefficient	reverse current		clamping voltage
	V_Z (V)			r_{diff} (Ω)	S_Z (%/°C)	I_R (μA) at V_R (V)		at $t_p = 1 \text{ ms}; 80 \text{ W}$
	at $I_{Z\text{test}} = 10 \text{ mA}$			at $I_{Z\text{test}} = 10 \text{ mA}$	at $I_{Z\text{test}} = 10 \text{ mA}$	max.		$V_{\text{CL}}(R)$ (V)
	min.	nom.	max.	max.	typ.			typ.
C16	15.3	16	17.1	16	+0.06	5	11	21.4
C18	16.8	18	19.1	20	+0.06	5	13	23.9
C20	18.8	20	21.2	22	+0.06	5	14	26.5
C22	20.8	22	23.3	23	+0.06	5	15	29.1
C24	22.7	24	25.9	25	+0.06	5	17	32.4
C27	25.1	27	28.9	35	+0.06	5	19	36.1
C30	28	30	32	40	+0.07	5	21	40.0
C33	31	33	35	45	+0.07	5	23	43.8
C36	34	36	38	50	+0.07	5	25	47.5
	at $I_{Z\text{test}} = 5 \text{ mA}$			at $I_{Z\text{test}} = 5 \text{ mA}$	at $I_{Z\text{test}} = 5 \text{ mA}$			
C39	37	39	41	60	+0.07	5	27	51.2
C43	40	43	46	70	+0.08	5	30	57.5
C47	44	47	50	80	+0.08	5	33	62.5
C51	48	51	54	95	+0.08	5	36	67.5
C56	52	56	60	105	+0.08	5	39	75.0
C62	58	62	66	110	+0.08	5	43	82.5
C68	64	68	72	120	+0.08	5	48	90.0
C75	70	75	79	145	+0.08	5	52	98.8
C82	77	82	87	175	+0.09	5	55	108.8
C91	85	91	96	200	+0.09	5	60	120.0
C100	94	100	106	220	+0.09	5	66	132.5
C110	104	110	116	250	+0.09	5	70	145.0
C120	114	120	127	270	+0.10	5	80	158.8
C130	124	130	141	300	+0.10	5	90	176.2
	at $I_{Z\text{test}} = 2 \text{ mA}$			at $I_{Z\text{test}} = 2 \text{ mA}$	at $I_{Z\text{test}} = 2 \text{ mA}$			
C150	138	150	156	950	+0.11	5	100	195.0
C160	153	160	171	1000	+0.11	5	110	213.8
C180	168	180	191	1100	+0.11	5	120	238.8
C200	188	200	212	1250	+0.11	5	140	265.0



OPERATING NOTES

Dissipation and heatsink considerations

a) Steady-state conditions

The maximum allowable steady-state dissipation P_s is given by the relationship:—

$$P_{s \text{ max.}} = \frac{T_{j \text{ max}} - T_{\text{amb}}}{R_{\text{th } j-a}}$$

Where $T_{j \text{ max}}$ is the maximum permissible operating junction temperature,

T_{amb} is the ambient temperature,

$R_{\text{th } j-a}$ is the total thermal resistance between junction and ambient.

b) Pulse conditions (see Fig.2)

The maximum pulse power $P_m \text{ max.}$ is given by the formula

$$P_{m \text{ max.}} = \frac{(T_{j \text{ max}} - T_{\text{amb}}) - (P_s R_{\text{th } j-a})}{Z_{\text{th}}}$$

Where P_s is the steady-state dissipation, excluding that in the pulses,

Z_{th} is the effective transient thermal resistance of the device between junction and ambient and is a function of the pulse duration t and duty cycle δ (see Fig.7).

δ is the duty cycle and is equal to the pulse duration t divided by the periodic time T .

The steady-state power P_s when biased in the zener direction at a given zener current can be found from Fig.6. With the additional pulsed power dissipation $P_m \text{ max.}$ calculated from the above expression, the total peak zener power dissipation P_{tot} is $P_s + P_m \text{ max.}$ From Fig.6 the peak zener current at P_{tot} can now be read.

For pulse durations longer than the temperature stabilisation time of the diode t_{stab} , the maximum allowable pulse power is equal to the steady-state power $P_s \text{ max.}$ The temperature stabilisation time for the BZX61 is 100s (see Fig.7).



OPERATING NOTES (contd.)

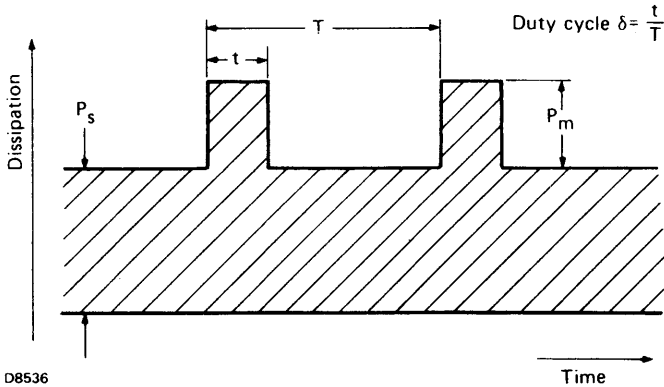

Fig.2

SOLDERING RECOMMENDATIONS

At a maximum iron temperature of 300 °C, the maximum permissible soldering time is 3 seconds, provided that the soldering spot is at least 5 mm from the seal.

DIP SOLDERING

At a maximum solder temperature of 300 °C, the maximum permissible soldering time is 3 seconds, provided that the soldering spot is at least 5 mm from the seal.

Note: If the diode is in contact with the printed board the maximum permissible temperature of the point of contact is 125 °C.

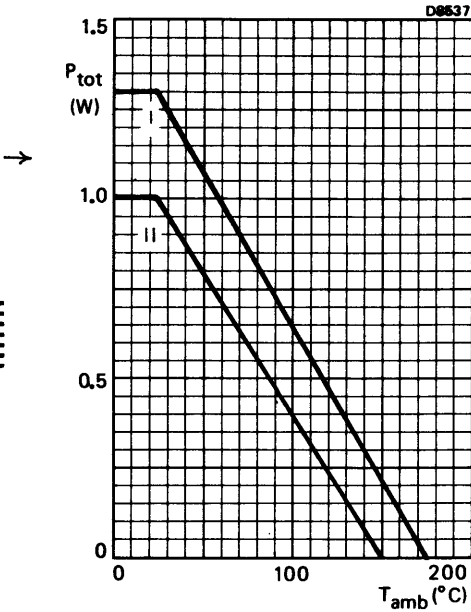

Fig.3 Continuous power rating.

For types in excess of 130 V the continuous reverse dissipation should be kept within the area II.

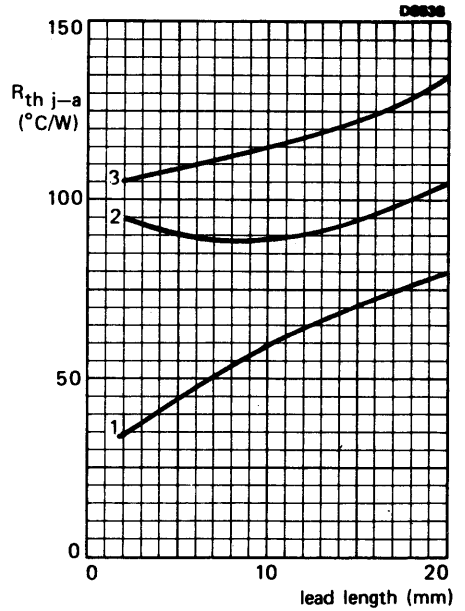
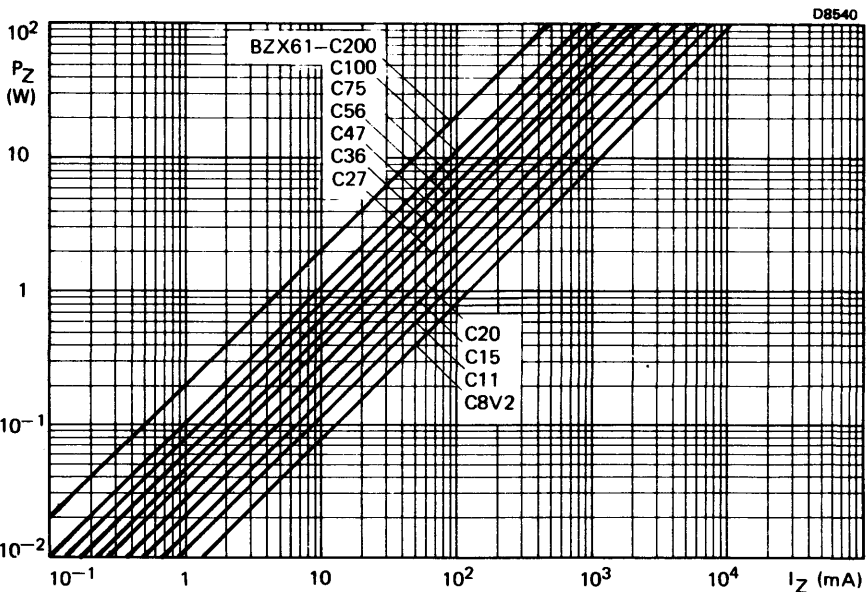
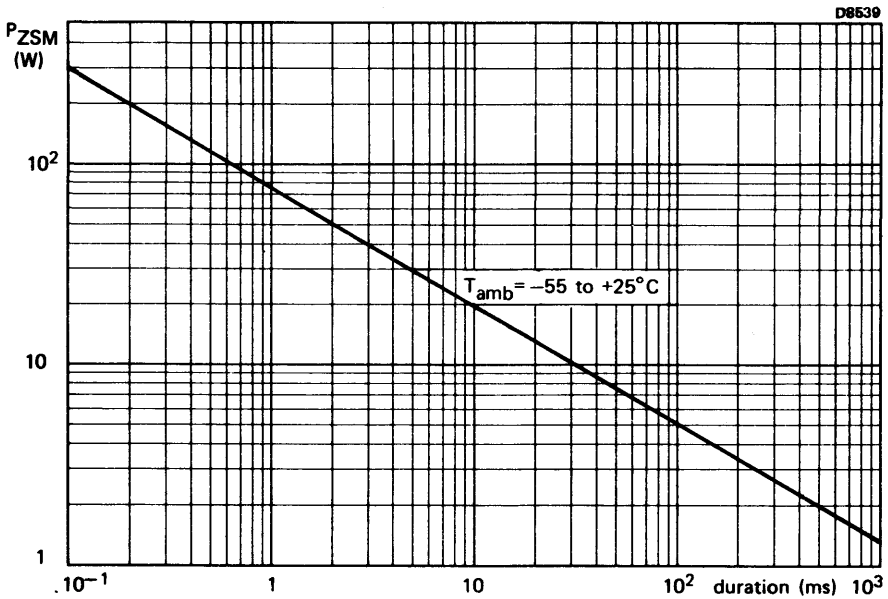

Fig.4 Mounting methods

1. Infinite heatsink at end of lead.
2. Typical printed circuit board with large area of copper (1 cm² per lead).
3. Tag mounting.





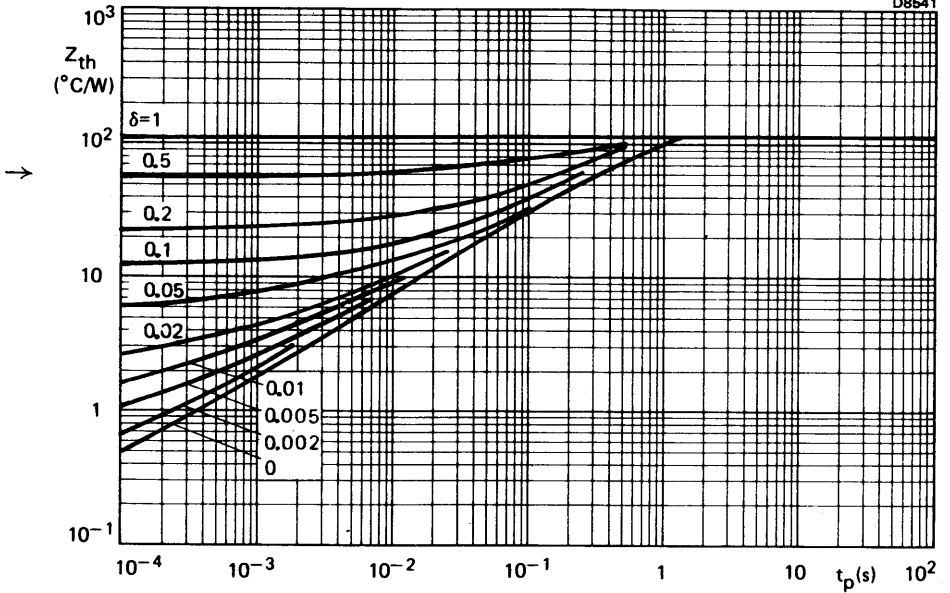
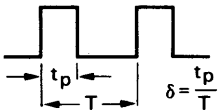

Fig.7



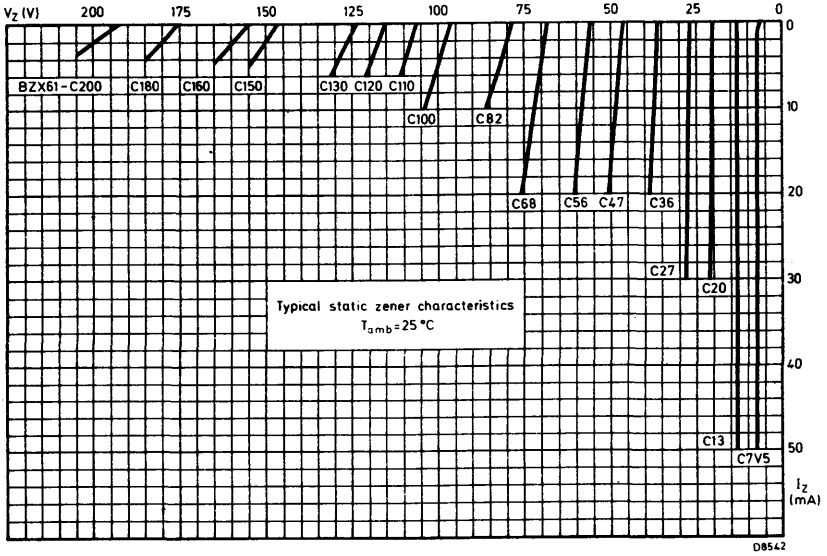

Fig.8

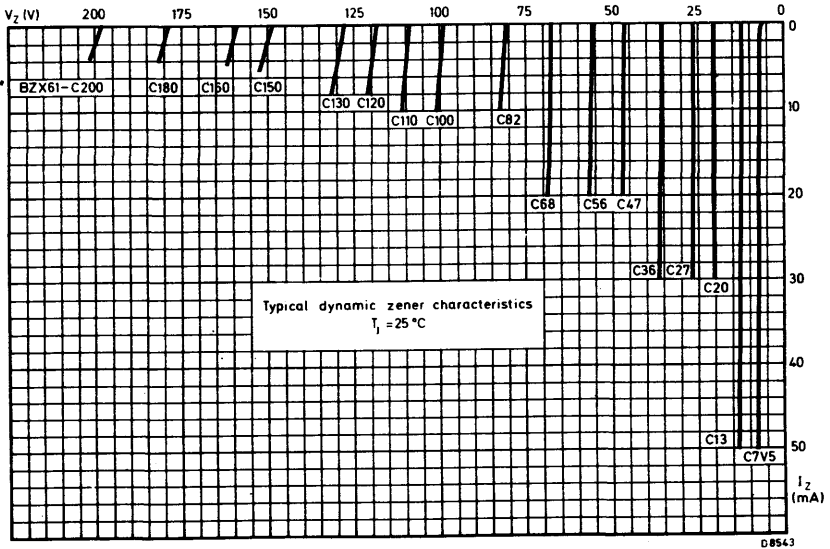

Fig.9



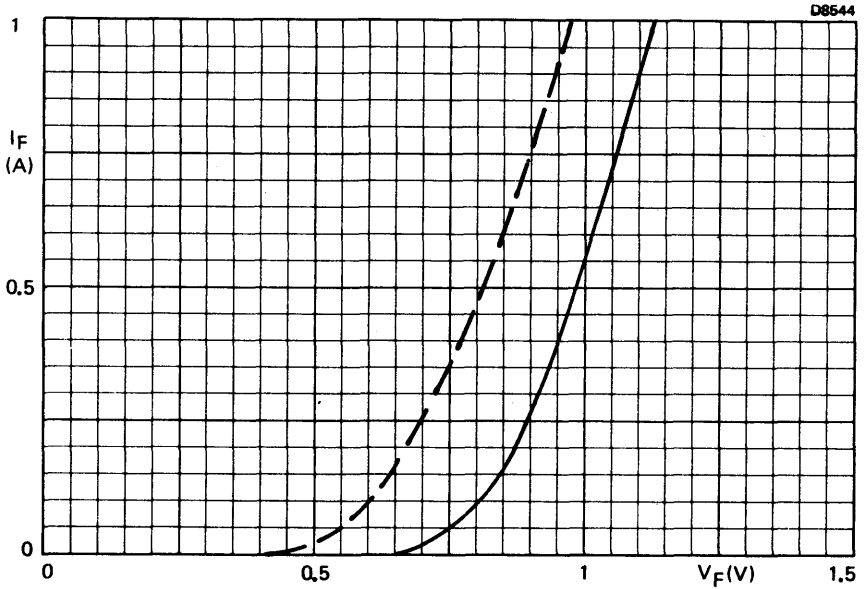

Fig.10 Typical values; — $T_j = 25\text{ }^\circ\text{C}$; - - - $T_j = 150\text{ }^\circ\text{C}$

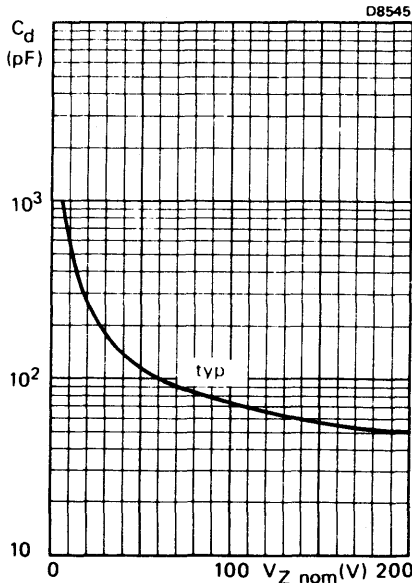

Fig.11 $V_R = 2\text{ V}$; $f = 500\text{ kHz}$; $T_{amb} = 25\text{ }^\circ\text{C}$



D8546

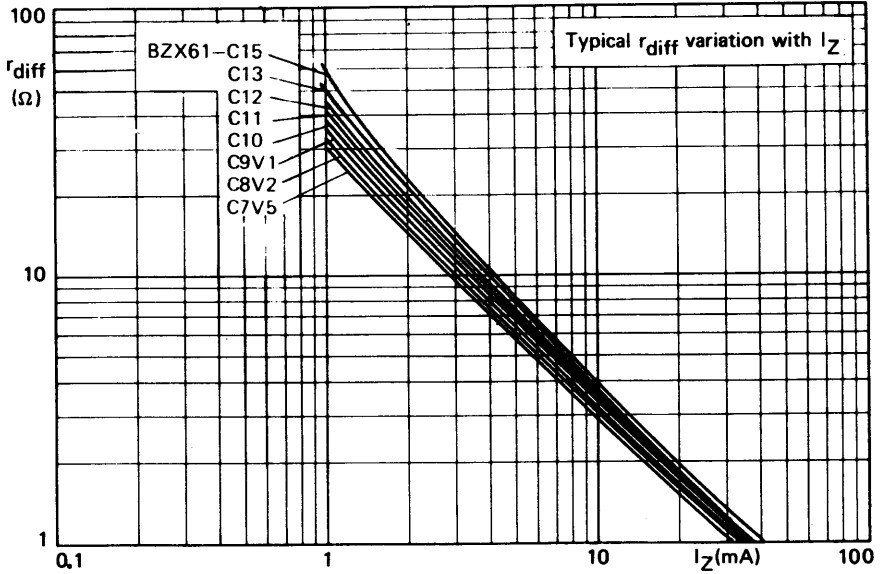

Fig.12 $T_j = 25\text{ }^\circ\text{C}$; $f = 1\text{ kHz}$

D8547

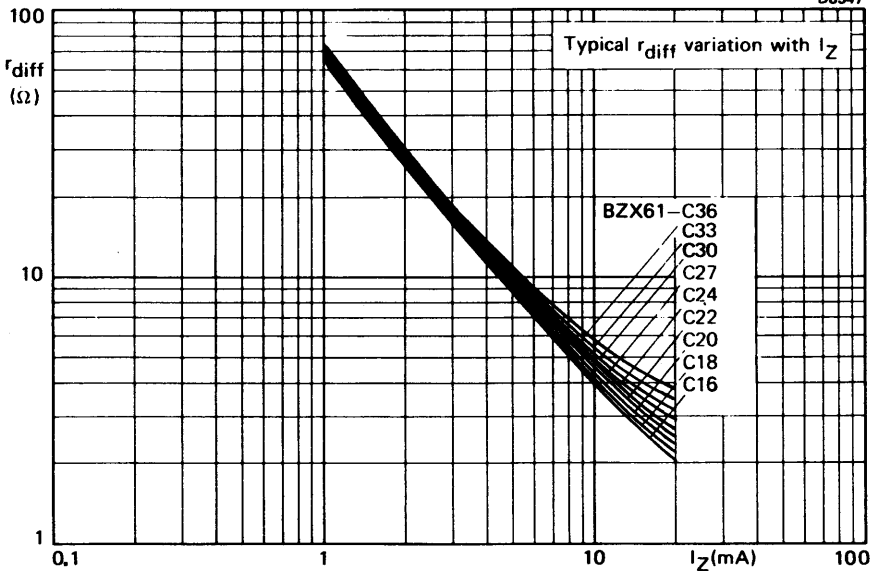

Fig.13 $T_j = 25\text{ }^\circ\text{C}$; $f = 1\text{ kHz}$



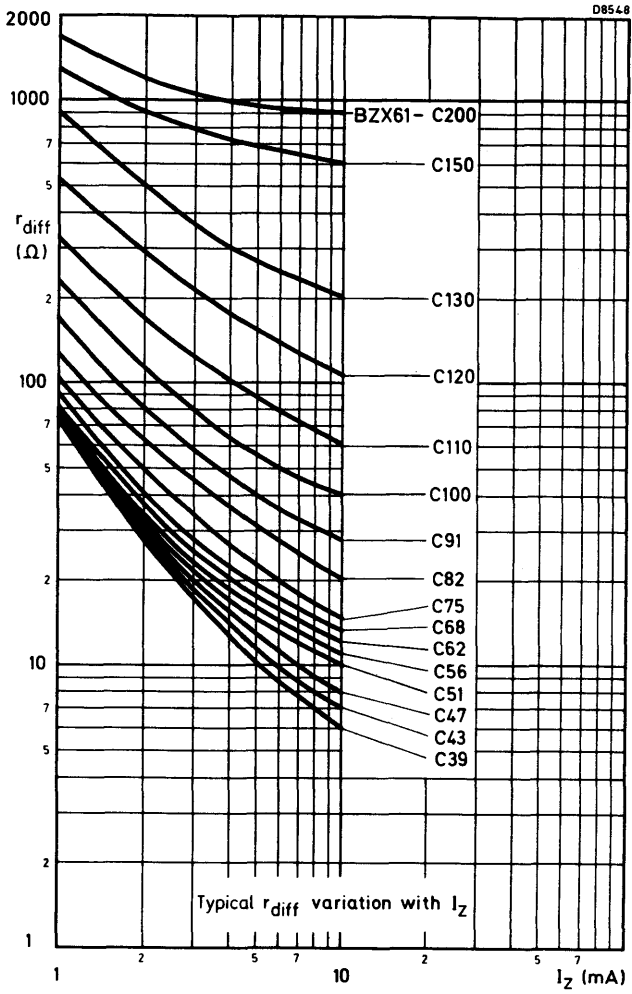

Fig. 14 $T_j = 25^\circ\text{C}$; $f = 1\text{ kHz}$



VOLTAGE REGULATOR DIODES



Silicon planar diodes in DO-35 envelopes intended for use as low voltage stabilizers or voltage references. They are available in two series; one to the international standardized E24 ($\pm 5\%$) range and the other with $\pm 2\%$ tolerance on working voltage. Each series consists of 37 types with nominal working voltages ranging from 2,4 V to 75 V.

QUICK REFERENCE DATA

Working voltage range	V_Z	nom.	2,4 to 75 V
Total power dissipation	P_{tot}	max.	500 mW *
Non-repetitive peak reverse power dissipation	P_{ZSM}	max.	30 W
Junction temperature	T_j	max.	200 °C
Thermal resistance from junction to tie-point	$R_{th j-tp}$	=	0,30 °C/mW

* If leads are kept at $T_{tp} = 50$ °C at 8 mm from body.

MECHANICAL DATA

Dimensions in mm

Fig. 1 DO-35.

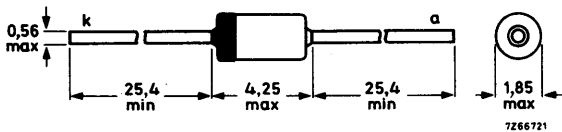

Cathode indicated by coloured band.
The diodes are type-branded

Products approved to CECC 50 005-005, available on request.



BZX79 SERIES

RATINGS

Limiting values in accordance with the Absolute Maximum System (IEC 134)

Average forward current (averaged
over any 20 ms period)

$I_F(AV)$ max. 250 mA

Repetitive peak forward current

I_{FRM} max. 250 mA

→ Total power dissipation

P_{tot} max. 500 mW *
max. 400 mW **

Non-repetitive peak reverse power dissipation
 $t = 100 \mu s$; $T_j = 150 \text{ }^\circ\text{C}$

P_{ZSM} max. 30 W

Storage temperature

T_{stg} $-65 \text{ to } +200 \text{ }^\circ\text{C}$

Junction temperature

T_j max. 200 $^\circ\text{C}$

→ THERMAL RESISTANCE

From junction to tie-point

$R_{th j-tp} = 0,30 \text{ }^\circ\text{C/mW}^*$

From junction to ambient

$R_{th j-a} = 0,38 \text{ }^\circ\text{C/mW}^{**}$

→ CHARACTERISTICS

$T_j = 25 \text{ }^\circ\text{C}$

Forward voltage

$I_F = 10 \text{ mA}$

$V_F < 0,9 \text{ V}$

→ Reverse current

BZX79- .2V4

$V_R = 1 \text{ V}$

$I_R < 50 \mu\text{A}$

.2V7

$V_R = 1 \text{ V}$

$I_R < 20 \mu\text{A}$

.3V0

$V_R = 1 \text{ V}$

$I_R < 10 \mu\text{A}$

.3V3

$V_R = 1 \text{ V}$

$I_R < 5 \mu\text{A}$

.3V6

$V_R = 1 \text{ V}$

$I_R < 5 \mu\text{A}$

.3V9

$V_R = 1 \text{ V}$

$I_R < 3 \mu\text{A}$

.4V3

$V_R = 1 \text{ V}$

$I_R < 3 \mu\text{A}$

.4V7

$V_R = 2 \text{ V}$

$I_R < 3 \mu\text{A}$

.5V1

$V_R = 2 \text{ V}$

$I_R < 2 \mu\text{A}$

.5V6

$V_R = 2 \text{ V}$

$I_R < 1 \mu\text{A}$

.6V2

$V_R = 4 \text{ V}$

$I_R < 3 \mu\text{A}$

.6V8

$V_R = 4 \text{ V}$

$I_R < 2 \mu\text{A}$

.7V5

$V_R = 5 \text{ V}$

$I_R < 1 \mu\text{A}$

.8V2

$V_R = 5 \text{ V}$

$I_R < 700 \text{ nA}$

.9V1

$V_R = 6 \text{ V}$

$I_R < 500 \text{ nA}$

.10

$V_R = 7 \text{ V}$

$I_R < 200 \text{ nA}$

.11 to .13

$V_R = 8 \text{ V}$

$I_R < 100 \text{ nA}$

.15 to .75

$V_R = 0,7 V_{Znom}$

$I_R < 50 \text{ nA}$

. = B for 2% tolerance

. = C for E24 ($\pm 5\%$) tolerance

* If leads are kept at $T_{tp} = 50 \text{ }^\circ\text{C}$ at 8 mm from body. For the types 2V4 and 2V7 the power dissipation is limited by $T_{j \text{ max}} = 150 \text{ }^\circ\text{C}$.

** In still air at maximum lead length up to $T_{amb} = 50 \text{ }^\circ\text{C}$.

$T_j = 25^\circ\text{C}$ $\pm 24 (\pm 5\%)$ logarithmic range (for $\pm 2\%$ tolerance range see page 5).

BZX79-...	working voltage		differential resistance		temperature coefficient			diode capacitance	
	V_Z (V)		r_{diff} (Ω)		S_Z (mV/ $^\circ\text{C}$)			C_d (pF); $f = 1$ MHz	
	at $I_{Z\text{test}} = 5$ mA		at $I_{Z\text{test}} = 5$ mA		at $I_{Z\text{test}} = 5$ mA			$V_R = 0$	
	min.	max.	typ.	max.	min.	typ.	max.	typ.	max.
C2V4	2,2	2,6	70	100	-3,5	-1,6	0	375	450
C2V7	2,5	2,9	75	100	-3,5	-2,0	0	350	450
C3V0	2,8	3,2	80	95	-3,5	-2,1	0	350	450
C3V3	3,1	3,5	85	95	-3,5	-2,4	0	325	450
C3V6	3,4	3,8	85	90	-3,5	-2,4	0	300	450
C3V9	3,7	4,1	85	90	-3,5	-2,5	0	300	450
C4V3	4,0	4,6	80	90	-3,5	-2,5	0	275	450
C4V7	4,4	5,0	50	80	-3,5	-1,4	0,2	130	180
C5V1	4,8	5,4	40	60	-2,7	-0,8	1,2	110	160
C5V6	5,2	6,0	15	40	-2,0	1,2	2,5	95	140
C6V2	5,8	6,6	6	10	0,4	2,3	3,7	90	130
C6V8	6,4	7,2	6	15	1,2	3,0	4,5	85	110
C7V5	7,0	7,9	6	15	2,5	4,0	5,3	80	100
C8V2	7,7	8,7	6	15	3,2	4,6	6,2	75	95
C9V1	8,5	9,6	6	15	3,8	5,5	7,0	70	90
C10	9,4	10,6	8	20	4,5	6,4	8,0	70	90
C11	10,4	11,6	10	20	5,4	7,4	9,0	65	85
C12	11,4	12,7	10	25	6,0	8,4	10,0	65	85
C13	12,4	14,1	10	30	7,0	9,4	11,0	60	80
C15	13,8	15,6	10	30	9,2	11,4	13,0	55	75
C16	15,3	17,1	10	40	10,4	12,4	14,0	52	75
C18	16,8	19,1	10	45	12,4	14,4	16,0	47	70
C20	18,8	21,2	15	55	14,4	16,4	18,0	36	60
C22	20,8	23,3	20	55	16,4	18,4	20,0	34	60
C24	22,8	25,6	25	70	18,4	20,4	22,0	33	55
	at $I_{Z\text{test}} = 2$ mA		at $I_{Z\text{test}} = 2$ mA		at $I_{Z\text{test}} = 2$ mA				
C27	25,1	28,9	25	80	21,4	23,4	25,3	30	50
C30	28,0	32,0	30	80	24,4	26,6	29,4	27	50
C33	31,0	35,0	35	80	27,4	29,7	33,4	25	45
C36	34,0	38,0	35	90	30,4	33,0	37,4	23	45
C39	37,0	41,0	40	130	33,4	36,4	41,2	21	45
C43	40,0	46,0	45	150	37,6	41,2	46,6	21	40
C47	44,0	50,0	50	170	42,0	46,1	51,8	19	40
C51	48,0	54,0	60	180	46,6	51,0	57,2	19	40
C56	52,0	60,0	70	200	52,2	57,0	63,8	18	40
C62	58,0	66,0	80	215	58,8	64,4	71,6	17	35
C68	64,0	72,0	90	240	65,6	71,7	79,8	17	35
C75	70,0	79,0	95	255	73,4	80,2	88,6	16,5	35

BZX79 SERIES

$T_j = 25\text{ }^\circ\text{C}$

E24 ($\pm 5\%$) logarithmic range (for $\pm 2\%$ tolerance range see page 6).

BZX79-...	working voltage			differential resistance		working voltage			differential resistance	
	V_Z (V)			r_{diff} (Ω)		V_Z (V)			r_{diff} (Ω)	
	at $I_Z = 1\text{ mA}$			at $I_Z = 1\text{ mA}$		at $I_Z = 20\text{ mA}$			at $I_Z = 20\text{ mA}$	
	min.	nom.	max.	typ.	max.	min.	nom.	max.	typ.	max.
C2V4	1,7	1,9	2,1	275	600	2,6	2,9	3,2	25	50
C2V7	1,9	2,2	2,4	300	600	3,0	3,3	3,6	25	50
→ C3V0	2,1	2,4	2,7	325	600	3,3	3,6	3,9	25	50
C3V3	2,3	2,6	2,9	350	600	3,6	3,9	4,2	20	40
C3V6	2,7	3,0	3,3	375	600	3,9	4,2	4,5	20	40
→ C3V9	2,9	3,2	3,5	400	600	4,1	4,4	4,7	15	30
C4V3	3,3	3,6	4,0	410	600	4,4	4,7	5,1	15	30
C4V7	3,7	4,2	4,7	425	500	4,5	5,0	5,4	8	15
C5V1	4,2	4,7	5,3	400	480	5,0	5,4	5,9	6	15
C5V6	4,8	5,4	6,0	80	400	5,2	5,7	6,3	4	10
C6V2	5,6	6,1	6,6	40	150	5,8	6,3	6,8	3	6
C6V8	6,3	6,7	7,2	30	80	6,4	6,9	7,4	2,5	6
C7V5	6,9	7,4	7,9	30	80	7,0	7,6	8,0	2,5	6
C8V2	7,6	8,1	8,7	40	80	7,7	8,3	8,8	3	6
C9V1	8,4	9,0	9,6	40	100	8,5	9,2	9,7	4	8
C10	9,3	9,9	10,6	50	150	9,4	10,1	10,7	4	10
C11	10,2	10,9	11,6	50	150	10,4	11,1	11,8	5	10
C12	11,2	11,9	12,7	50	150	11,4	12,1	12,9	5	10
C13	12,3	12,9	14,0	50	170	12,5	13,1	14,2	5	15
C15	13,7	14,9	15,5	50	200	13,9	15,1	15,7	6	20
C16	15,2	15,9	17,0	50	200	15,4	16,1	17,2	6	20
C18	16,7	17,9	19,0	50	225	16,9	18,1	19,2	6	20
C20	18,7	19,9	21,1	60	225	18,9	20,1	21,4	7	20
C22	20,7	21,9	23,2	60	250	20,9	22,1	23,4	7	25
C24	22,7	23,9	25,5	60	250	22,9	24,1	25,7	7	25
	at $I_Z = 0,1\text{ mA}$			at $I_Z = 0,5\text{ mA}$		at $I_Z = 10\text{ mA}$			at $I_Z = 10\text{ mA}$	
C27	25,0	26,9	28,9	65	300	25,2	27,1	29,3	10	45
C30	27,8	29,9	32,0	70	300	28,1	30,1	32,4	15	50
C33	30,8	32,9	35,0	75	325	31,1	33,1	35,4	20	55
C36	33,8	35,9	38,0	80	350	34,1	36,1	38,4	25	60
C39	36,7	38,9	41,0	80	350	37,1	39,1	41,5	25	70
C43	39,7	42,9	46,0	85	375	40,1	43,1	46,5	25	80
C47	43,7	46,8	50,0	85	375	44,1	47,1	50,5	30	90
C51	47,6	50,8	54,0	90	400	48,1	51,1	54,6	35	100
C56	51,5	55,7	60,0	100	425	52,1	56,1	60,8	45	110
C62	57,4	61,7	66,0	120	450	58,2	62,1	67,0	60	120
C68	63,4	67,7	72,0	150	475	64,2	68,2	73,2	75	130
C75	69,4	74,7	79,0	170	500	70,3	75,3	80,2	90	140

$T_j = 25\text{ }^\circ\text{C}$ $\pm 2\%$ tolerance range.

BZX79-...	working voltage		differential resistance		temperature coefficient			diode capacitance	
	V_Z (V)		r_{diff} (Ω)		S_Z (mV/ $^\circ\text{C}$)			C_d (pF); $f = 1\text{ MHz}$	
	at $I_{Ztest} = 5\text{ mA}$		at $I_{Ztest} = 5\text{ mA}$		at $I_{Ztest} = 5\text{ mA}$			$V_R = 0$	
	min.	max.	typ.	max.	min.	typ.	max.	typ.	max.
B2V4	2,35	2,45	70	100	-2,6	-1,6	-0,6	375	450
B2V7	2,65	2,75	75	100	-3,0	-2,0	-1,0	350	450
B3V0	2,94	3,06	80	95	-3,0	-2,1	-1,2	350	450
B3V3	3,23	3,37	85	95	-3,2	-2,4	-1,5	325	450
B3V6	3,53	3,67	85	90	-3,2	-2,4	-1,5	300	450
B3V9	3,82	3,98	85	90	-3,2	-2,5	-1,5	300	450
B4V3	4,21	4,39	80	90	-3,2	-2,5	-1,2	275	450
B4V7	4,61	4,79	50	80	-2,0	-1,4	-0,8	130	180
B5V1	5,00	5,20	40	60	-1,6	-0,8	0,5	110	160
B5V6	5,49	5,71	15	40	-0,7	1,2	2,2	95	140
B6V2	6,08	6,32	6	10	1,0	2,3	3,2	90	130
B6V8	6,66	6,94	6	15	2,0	3,0	4,0	85	110
B7V5	7,35	7,65	6	15	3,0	4,0	4,8	80	100
B8V2	8,04	8,36	6	15	3,6	4,6	5,5	75	95
B9V1	8,92	9,28	6	15	4,3	5,5	6,5	70	90
B10	9,80	10,20	8	20	5,2	6,4	7,4	70	90
B11	10,80	11,20	10	20	6,2	7,4	8,5	65	85
B12	11,80	12,20	10	25	7,0	8,4	9,5	65	85
B13	12,70	13,30	10	30	7,8	9,4	10,5	60	80
B15	14,70	15,30	10	30	10,0	11,4	12,4	55	75
B16	15,70	16,30	10	40	10,9	12,4	13,5	52	75
B18	17,60	18,40	10	45	12,8	14,4	15,6	47	70
B20	19,60	20,40	15	55	14,8	16,4	17,6	36	60
B22	21,60	22,40	20	55	16,8	18,4	19,6	34	60
B24	23,50	24,50	25	70	18,7	20,4	21,6	33	55
	at $I_{Ztest} = 2\text{ mA}$		at $I_{Ztest} = 2\text{ mA}$		at $I_{Ztest} = 2\text{ mA}$				
B27	26,50	27,50	25	80	21,4	23,4	25,3	30	50
B30	29,40	30,60	30	80	24,4	26,6	29,0	27	50
B33	32,30	33,70	35	80	27,4	29,7	32,5	25	45
B36	35,30	36,70	35	90	30,4	33,0	36,0	23	45
B39	38,20	39,80	40	130	33,4	36,4	40,0	21	45
B43	42,10	43,90	45	150	38,0	41,2	45,0	21	40
B47	46,10	47,90	50	170	42,5	46,1	50,0	19	40
B51	50,00	52,00	60	180	47,0	51,0	55,0	19	40
B56	54,90	57,10	70	200	52,5	57,0	62,0	18	40
B62	60,80	63,20	80	215	59,0	64,4	69,0	17	35
B68	66,60	69,40	90	240	66,0	71,7	77,0	17	35
B75	73,50	76,50	95	255	74,0	80,2	86,0	16,5	35

BZX79 SERIES

$T_j = 25\text{ }^\circ\text{C}$

$\pm 2\%$ tolerance range.

BZX79....	working voltage		differential resistance		working voltage		differential resistance	
	V_Z (V) at $I_Z = 1\text{ mA}$		r_{diff} (Ω) at $I_Z = 1\text{ mA}$		V_Z (V) at $I_Z = 20\text{ mA}$		r_{diff} (Ω) at $I_Z = 20\text{ mA}$	
	nom.		typ.	max.	nom.		typ.	max.
B2V4	1,9		275	600	2,9		25	50
B2V7	2,2		300	600	3,3		25	50
→ B3V0	2,4		325	600	3,6		25	50
B3V3	2,6		350	600	3,9		20	40
B3V6	3,0		375	600	4,2		20	40
B3V9	3,2		400	600	4,4		15	30
→ B4V3	3,6		410	600	4,7		15	30
B4V7	4,2		425	500	5,0		8	15
B5V1	4,7		400	480	5,4		6	15
B5V6	5,4		80	400	5,7		4	10
B6V2	6,1		40	150	6,3		3	6
B6V8	6,7		30	80	6,9		2,5	6
B7V5	7,4		30	80	7,6		2,5	6
B8V2	8,1		40	80	8,3		3	6
B9V1	9,0		40	100	9,2		4	8
B10	9,9		50	150	10,1		4	10
B11	10,9		50	150	11,1		5	10
B12	11,9		50	150	12,1		5	10
B13	12,9		50	170	13,1		5	15
B15	14,9		50	200	15,1		6	20
B16	15,9		50	200	16,1		6	20
B18	17,9		50	225	18,1		6	20
B20	19,9		60	225	20,1		7	20
B22	21,9		60	250	22,1		7	25
B24	23,9		60	250	24,1		7	25
	at $I_Z = 0,1\text{ mA}$		at $I_Z = 0,5\text{ mA}$		at $I_Z = 10\text{ mA}$		at $I_Z = 10\text{ mA}$	
B27	26,9		65	300	27,1		10	45
B30	29,9		70	300	30,1		15	50
→ B33	32,9		75	325	33,1		20	55
B36	35,9		80	350	36,1		25	60
B39	38,9		80	350	39,1		25	70
B43	42,9		85	375	43,1		25	80
B47	46,8		85	375	47,1		30	90
→ B51	50,8		90	400	51,1		35	100
B56	55,7		100	425	56,1		45	110
B62	61,7		120	450	62,1		60	120
→ B68	67,7		150	475	68,2		75	130
B75	74,7		170	500	75,3		90	140

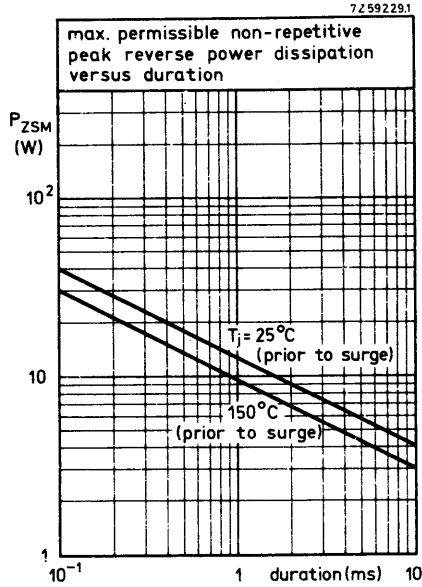

Fig. 2.

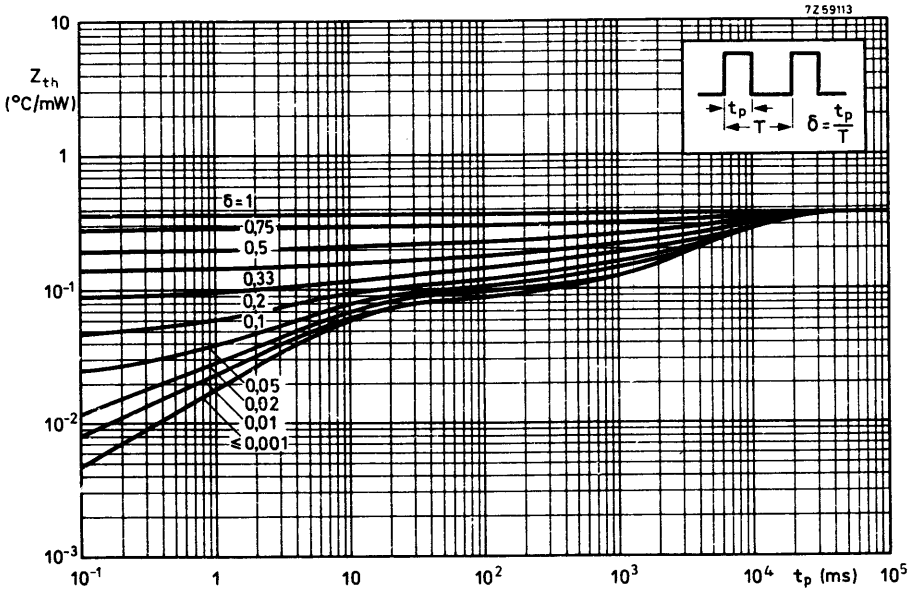

Fig. 3.

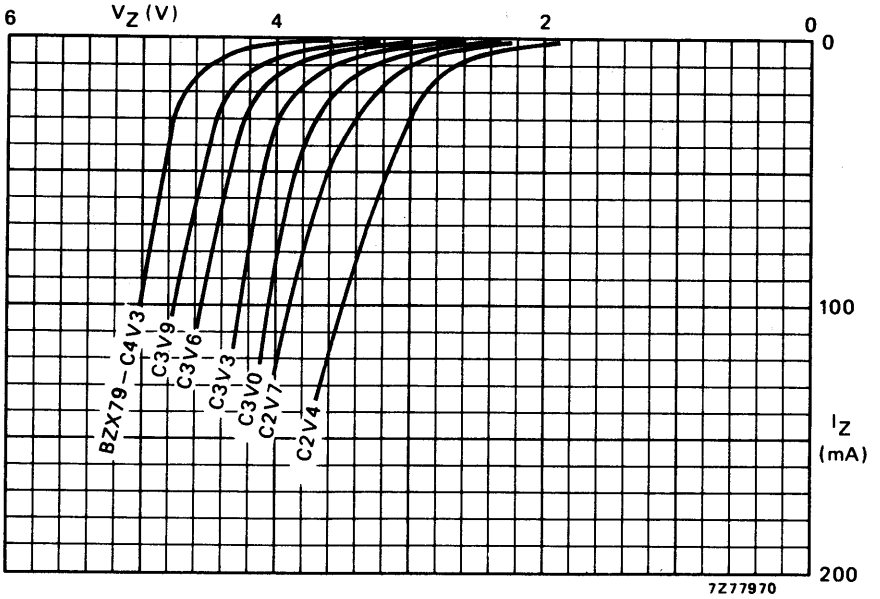

Fig. 4 Static characteristics; typical values; $T_{amb} = 25\text{ }^{\circ}\text{C}$.

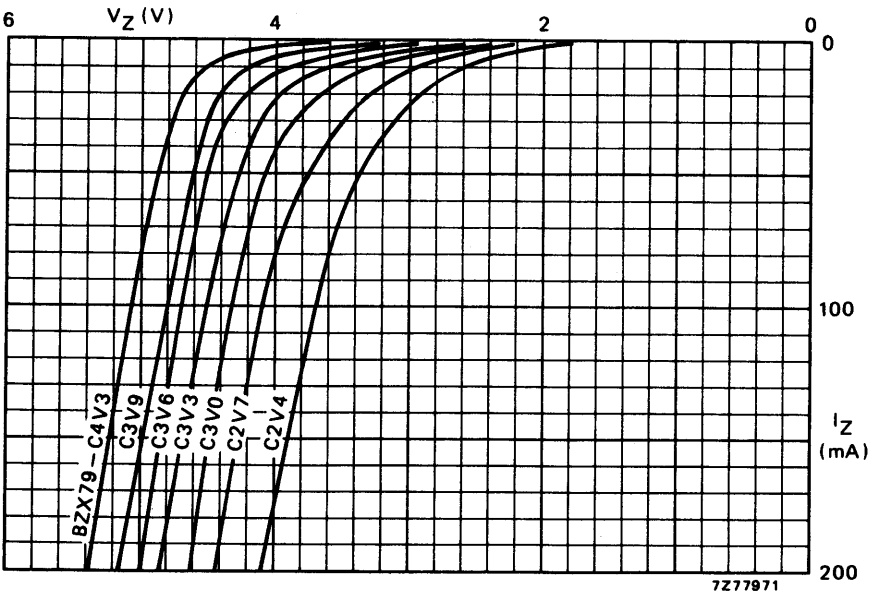

Fig. 5 Dynamic characteristics; typical values; $T_j = 25\text{ }^{\circ}\text{C}$.

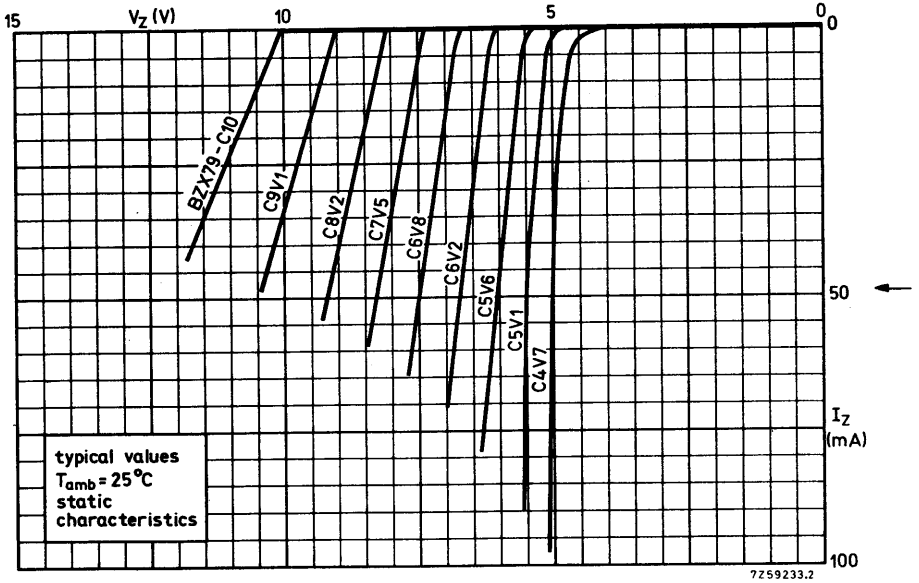

Fig. 6.

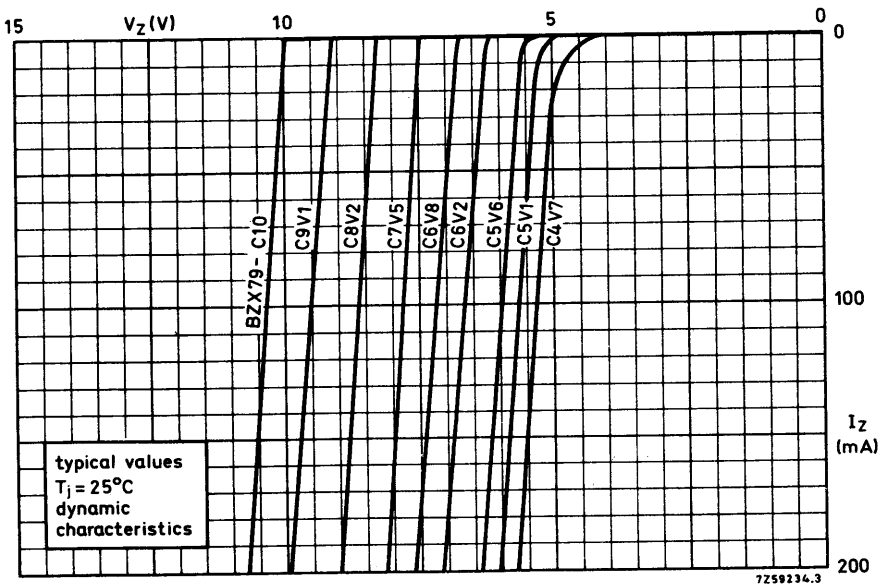

Fig. 7.

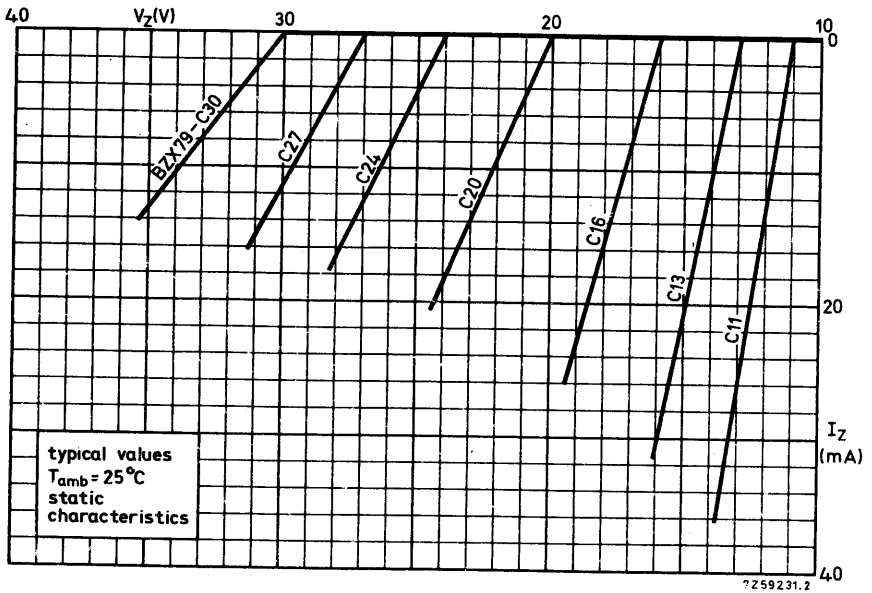

Fig. 8.

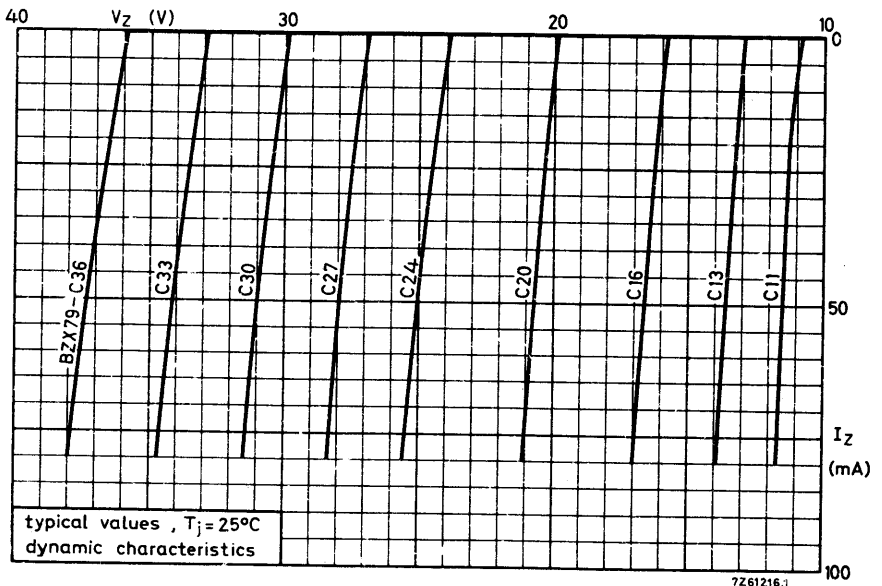

Fig. 9.

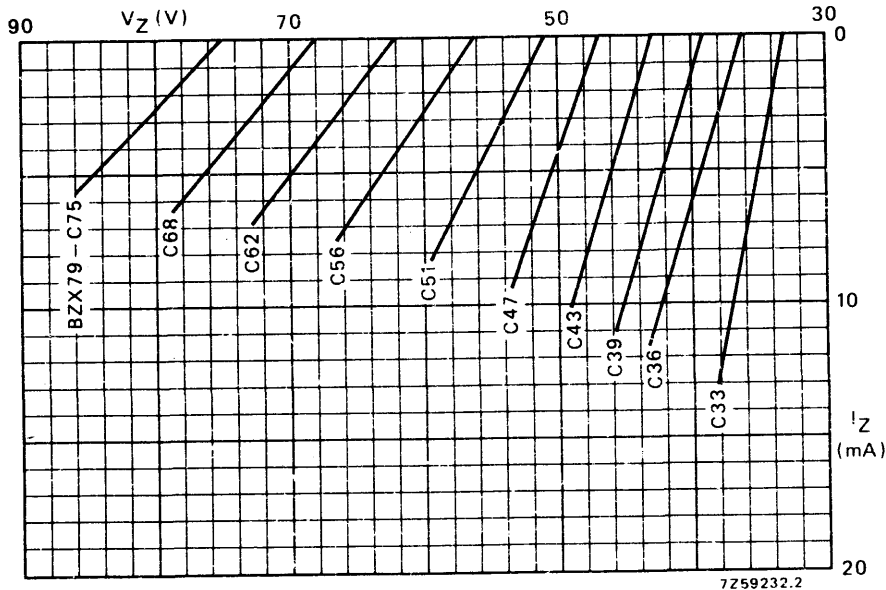

Fig. 10 Static characteristics; typical values; $T_{amb} = 25^\circ C$.

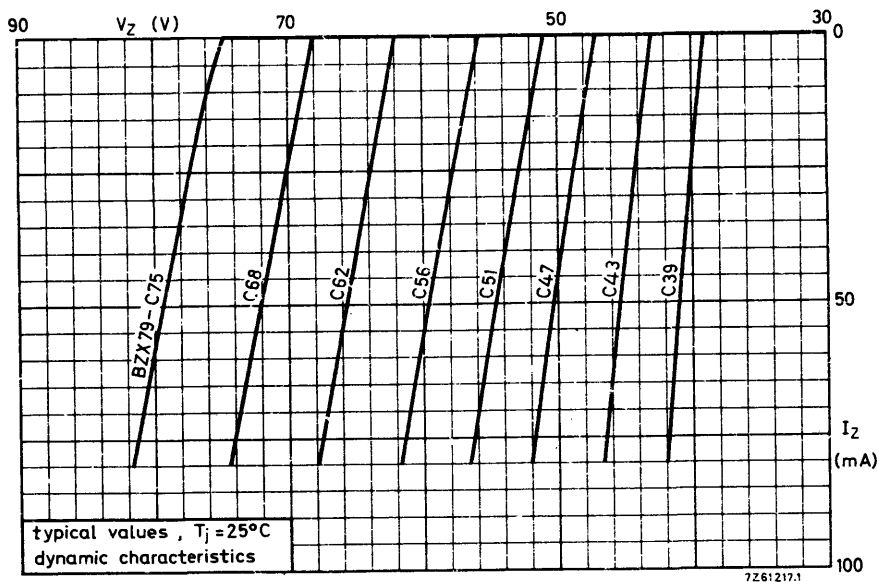

Fig. 11.

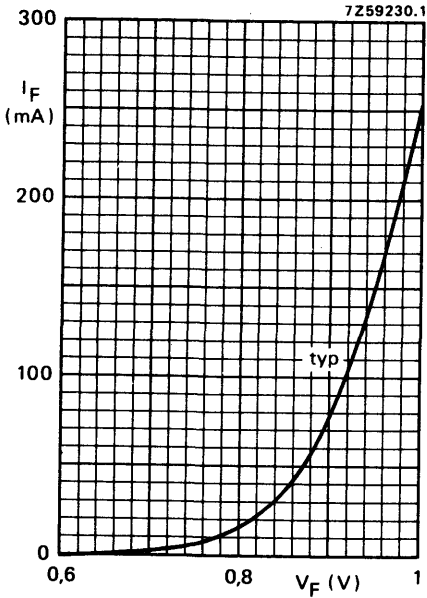

Fig. 12 $T_j = 25^\circ\text{C}$.

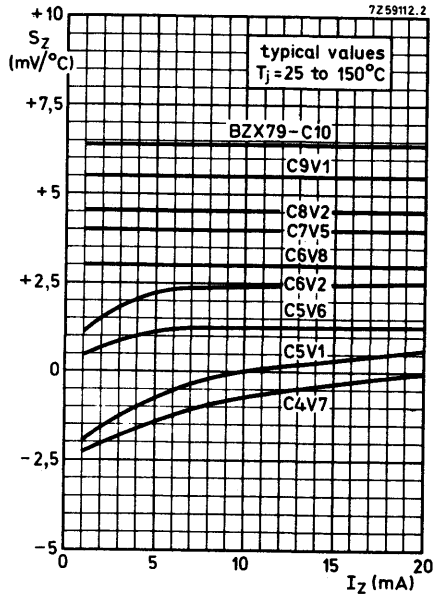

Fig. 13.

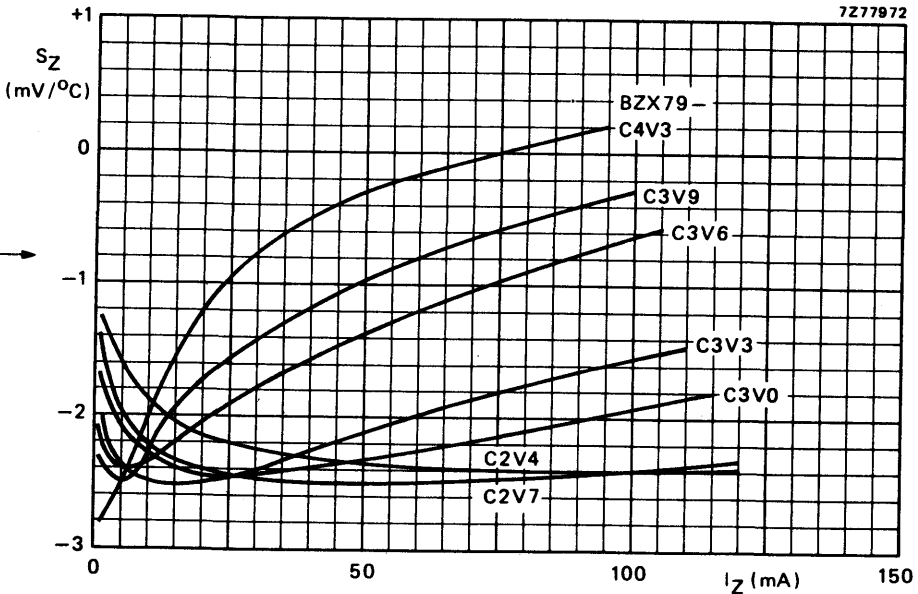

Fig. 14 Typical values; $T_j = 25$ to 150°C .

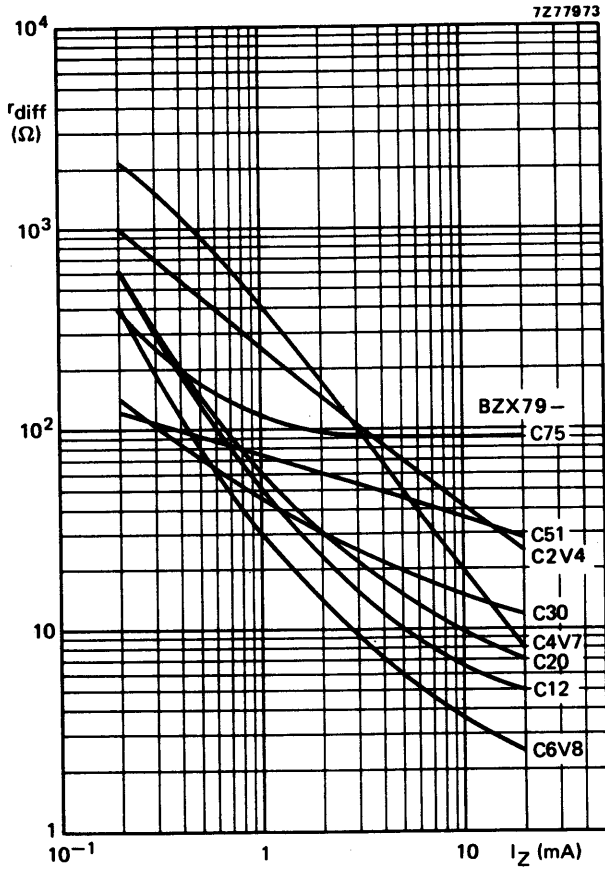

Fig. 15 Typical values; $T_j = 25^\circ\text{C}$; $f = 1\text{ kHz}$.

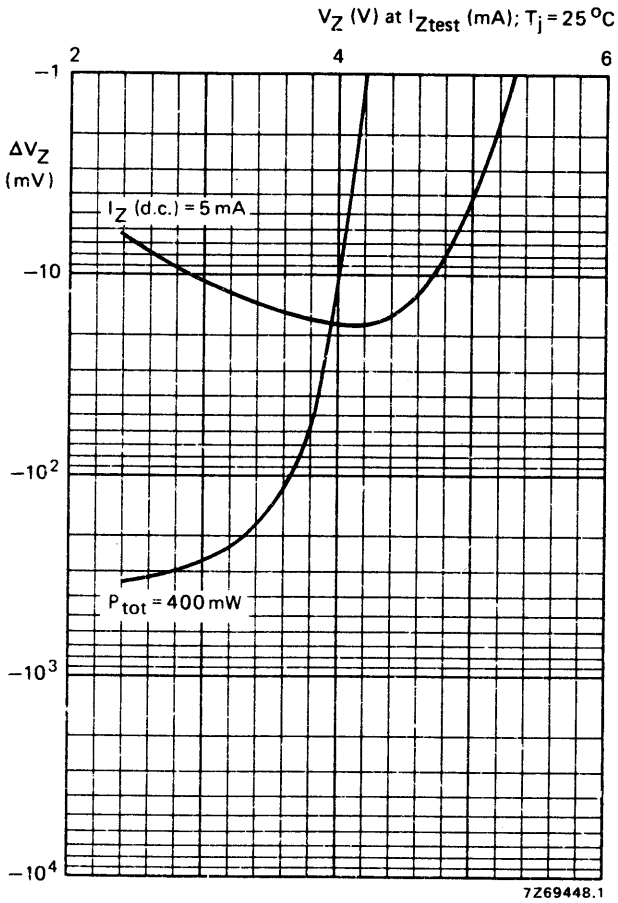

Fig. 16 Typical change of working voltage under operating conditions at $T_{\text{amb}} = 25^\circ\text{C}$.

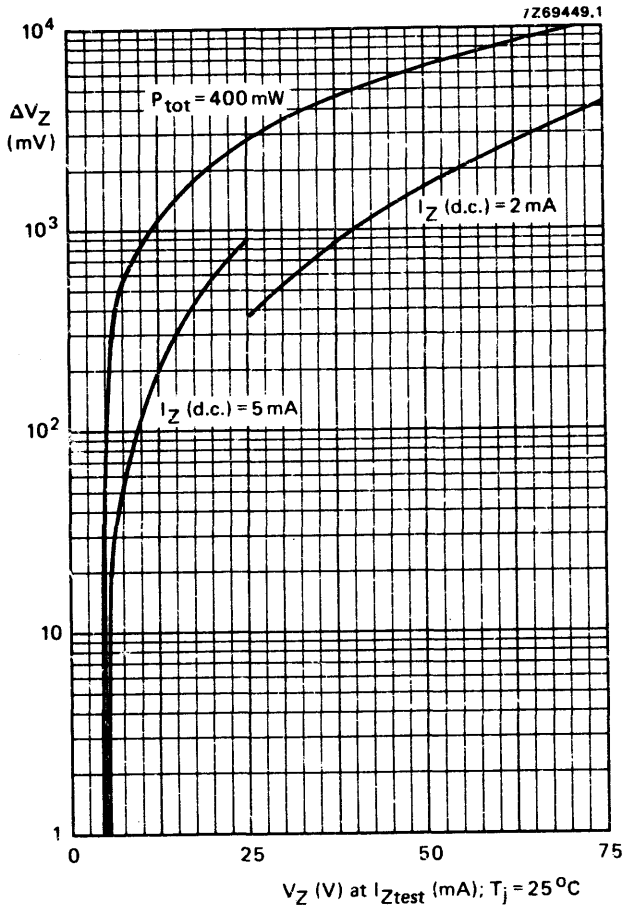

Fig. 17 Typical change of working voltage under operating conditions at $T_{amb} = 25$ °C.

SILICON PLANAR VOLTAGE REGULATOR DIODES

Silicon planar voltage regulator diodes in hermetically sealed glass envelopes intended for stabilization purposes.

The series covers the normalized range of nominal working voltages from 5,1 V to 75 V with a tolerance of $\pm 5\%$ (international standard E24).

QUICK REFERENCE DATA			
Working voltage range	V_Z	nom.	5,1 to 75 V
Working voltage tolerance (E24)			$\pm 5\%$
Total power dissipation	P_{tot}	max.	2,75 W
Junction temperature	T_j	max.	200 °C

MECHANICAL DATA

Dimensions in mm

SOD-51

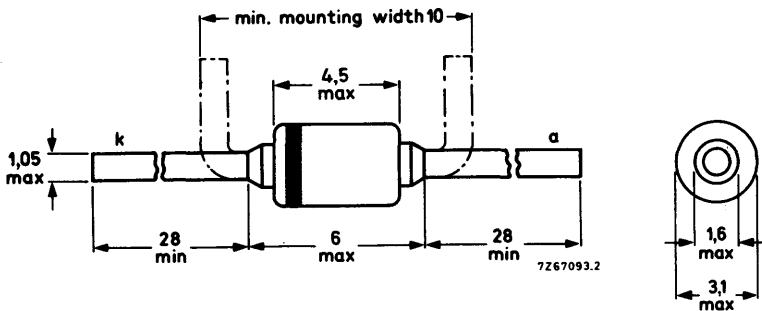

Cathode indicated by coloured band
The diodes are type-branded



BZX87

SERIES

RATINGS Limiting values in accordance with the Absolute Maximum System (IEC 134)

Currents

Working current (d. c.)	I_Z	limited by P_{tot} max
Repetitive peak working current	I_{ZRM}	limited by P_{ZRMmax}
Repetitive peak forward current	I_{FRM}	max. 400 mA

Power dissipation (see also graphs on pages 5 and 6)

Total power dissipation	P_{tot}	max. 1,5 W 1) max. 2,75 W 2)
Repetitive peak reverse power dissipation up to $T_{amb} = 175\text{ }^\circ\text{C}$; $t_p = 100\text{ }\mu\text{s}$; $\delta = 0,001$	P_{ZRM}	max. 7,5 W
Non-repetitive peak reverse power dissipation up to $T_{amb} = 25\text{ }^\circ\text{C}$; $t_p = 100\text{ }\mu\text{s}$	P_{ZSM}	max. 100 W

Temperatures

Storage temperature	T_{stg}	-65 to +200 $^\circ\text{C}$
Junction temperature	T_j	max. 200 $^\circ\text{C}$

THERMAL RESISTANCE (see also graphs on pages 5 and 6)

From junction to ambient when soldered to tags at max. lead length	$R_{th\ j-a}$	max. 117 $^\circ\text{C}/\text{W}$
--	---------------	------------------------------------

CHARACTERISTICS

Forward voltage at $I_F = 0,2\text{ A}$	V_F	< 1 V
---	-------	-------

Reverse current

BZX87-C5V1	} $V_R = 2\text{ V}$	I_R	< 10 μA
C5V6		I_R	< 5 μA
C6V2	} $V_R = 3\text{ V}$	I_R	< 3 μA
C6V8		I_R	< 1,5 μA
C7V5		I_R	< 0,6 μA
C8V2		I_R	< 0,4 μA
C9V1		I_R	< 0,3 μA
C10 to C75	$V_R = \frac{2}{3} V_{Znom}$	I_R	< 0,2 μA

1) Measured in still air up to $T_{amb} = 25\text{ }^\circ\text{C}$ and mounted to solder tags at maximum lead length.

2) If the temperature of the leads at 10 mm from the body is kept at 25 $^\circ\text{C}$.

CHARACTERISTICS (continued)

$T_j = 25\text{ }^\circ\text{C}$

BZX87-....	Working voltage		Temperature coefficient			Differential resistance		Diode capacitance C_d (pF)	
	V_Z (V)		S_Z (mV/ $^\circ\text{C}$)			r_{diff} (Ω)		at $f = 1\text{ MHz}$	
	at $I_Z = 50\text{ mA}$		at $I_Z = 50\text{ mA}$			at $I_Z = 50\text{ mA}$		$V_R = 0$	
	min.	max.	min.	typ.	max.	typ.	n.ax.	typ.	max.
C5V1	4,8	5,4	-1,5	0	1,5	4	10	200	250
C5V6	5,2	6,0	-0,2	1,5	2,5	2	5	180	225
C6V2	5,8	6,6	1,5	2,4	3,3	1,5	3	350	400
	at $I_Z = 20\text{ mA}$		at $I_Z = 20\text{ mA}$			at $I_Z = 20\text{ mA}$			
C6V8	6,4	7,2	2,2	3,1	3,9	1	3	300	350
C7V5	7,0	7,9	2,8	3,8	4,7	1	3	270	310
C8V2	7,7	8,7	3,5	4,5	5,5	1,5	4	250	280
C9V1	8,5	9,6	4,3	5,4	6,5	2	4	210	250
C10	9,4	10,6	5,2	6,3	7,5	2	5	190	230
C11	10,4	11,6	6,2	7,4	8,6	3	5	170	220
C12	11,4	12,7	7,2	8,4	9,8	3	6	165	200
C13	12,4	14,1	8,2	9,4	11,2	3	7	165	200
C15	13,8	15,6	9,6	11,4	12,8	4	10	160	190
	at $I_Z = 10\text{ mA}$		at $I_Z = 10\text{ mA}$			at $I_Z = 10\text{ mA}$			
C16	15,3	17,1	11,1	12,5	14,4	4	10	140	180
C18	16,8	19,1	12,6	14,5	16,6	5	15	120	160
C20	18,8	21,2	14,6	16,6	18,8	5	15	110	150
C22	20,8	23,3	16,6	18,6	20,9	5	20	100	135
C24	22,8	25,6	18,6	20,7	23,4	6	20	95	130
C27	25,1	28,9	21,0	23,8	26,8	7	25	90	120
C30	28	32	23,8	26,9	30,6	8	25	80	110
C33	31	35	26,6	30,0	34,2	10	30	75	95
C36	34	38	29,6	33,4	38,0	10	35	70	90
	at $I_Z = 5\text{ mA}$		at $I_Z = 5\text{ mA}$			at $I_Z = 5\text{ mA}$			
C39	37	41	32,6	37,0	41,6	15	40	65	80
C43	40	46	36,0	41,6	47,6	15	50	62	75
C47	44	50	40,4	46,1	52,6	20	60	60	75
C51	48	54	44,6	51,0	57,6	30	70	55	70
C56	52	60	49,2	56,6	64,8	35	80	52	65
C62	58	66	56,0	63,4	72,0	40	90	50	60
C68	64	72	62,4	70,4	79,2	45	110	46	58
C75	70	79	69,2	78,4	88,0	45	125	44	55

BZX87 SERIES

CHARACTERISTICS (continued)

$T_j = 25\text{ }^\circ\text{C}$

	Working voltage			Differential resistance		Working voltage			Differential resistance	
	V_Z (V)			r_{diff} (Ω)		V_Z (V)			r_{diff} (Ω)	
	at $I_Z = 1\text{ mA}$			at $I_Z = 1\text{ mA}$		at $I_Z = 100\text{ mA}$			at $I_Z = 100\text{ mA}$	
BZX87-....	min.	nom.	max.	typ.	max.	min.	nom.	max.	typ.	max.
C5V1	3,3	3,8	4,3	425	500	4,9	5,2	5,5	1,2	2,5
C5V6	4,1	5,3	5,8	400	500	5,3	5,7	6,1	1,0	2,0
C6V2	5,6	6,0	6,5	40	200	5,9	6,3	6,7	0,8	2,0
C6V8	6,3	6,7	7,1	40	120	6,5	6,9	7,3	0,6	2,0
C7V5	6,9	7,4	7,8	20	100	7,1	7,6	8,0	0,5	1,5
C8V2	7,6	8,1	8,6	20	100	7,8	8,3	8,8	0,5	1,5
C9V1	8,4	9,0	9,6	25	100	8,6	9,2	9,8	0,8	2,0
C10	9,3	9,9	10,5	30	120	9,5	10,1	10,8	0,8	2,0
C11	10,3	10,9	11,5	30	120	10,5	11,1	11,8	0,8	2,0
C12	11,2	11,9	12,6	30	150	11,5	12,1	12,9	1,0	2,0
C13	12,2	12,9	14,0	30	150	12,5	13,1	14,3	1,2	2,5
C15	13,6	14,9	15,4	30	150	13,9	15,1	15,8	1,2	2,5
	at $I_Z = 1\text{ mA}$			at $I_Z = 1\text{ mA}$		at $I_Z = 50\text{ mA}$			at $I_Z = 50\text{ mA}$	
C16	15,2	15,9	17,0	30	150	15,4	16,1	17,3	1,2	3,0
C18	16,7	17,9	19,0	30	150	16,9	18,1	19,3	2,0	5,0
C20	18,7	19,9	21,1	30	150	19,0	20,2	21,5	2,5	6,0
C22	20,7	21,9	23,2	30	150	21,0	22,2	23,7	2,5	6,0
C24	22,6	23,9	25,5	30	150	23,0	24,2	26,0	3,0	8,0
C27	24,9	26,9	28,8	30	150	25,3	27,2	29,2	4,0	8,0
C30	27,8	29,9	31,9	30	150	28,2	30,2	32,5	4,0	8,0
C33	29,8	32,9	34,9	30	150	31,2	33,3	35,5	5,0	10
C36	33,8	35,9	37,9	30	150	34,2	36,3	38,5	5,0	10
C39	36,8	38,9	40,9	40	150	37,5	39,5	42,0	6,0	12
C43	39,8	42,9	45,9	50	150	40,5	43,5	47,0	8	15
C47	43,8	46,9	49,9	55	200	44,5	47,5	51,0	10	20
C51	47,8	50,9	53,8	60	200	48,5	51,8	55,5	12	25
C56	51,8	55,9	59,8	60	200	52,5	56,8	61,5	15	30
C62	57,6	61,8	65,8	70	200	58,5	62,8	67,5	16	30
C68	63,5	67,6	71,7	80	225	65,0	69,0	74,0	18	35
C75	69,3	74,5	78,6	100	250	73,0	77,5	84,0	20	35

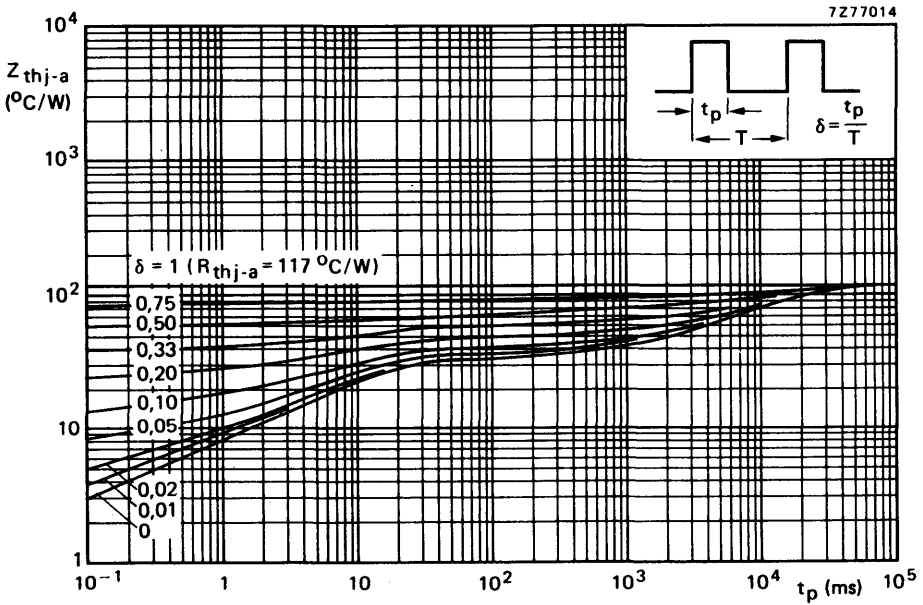
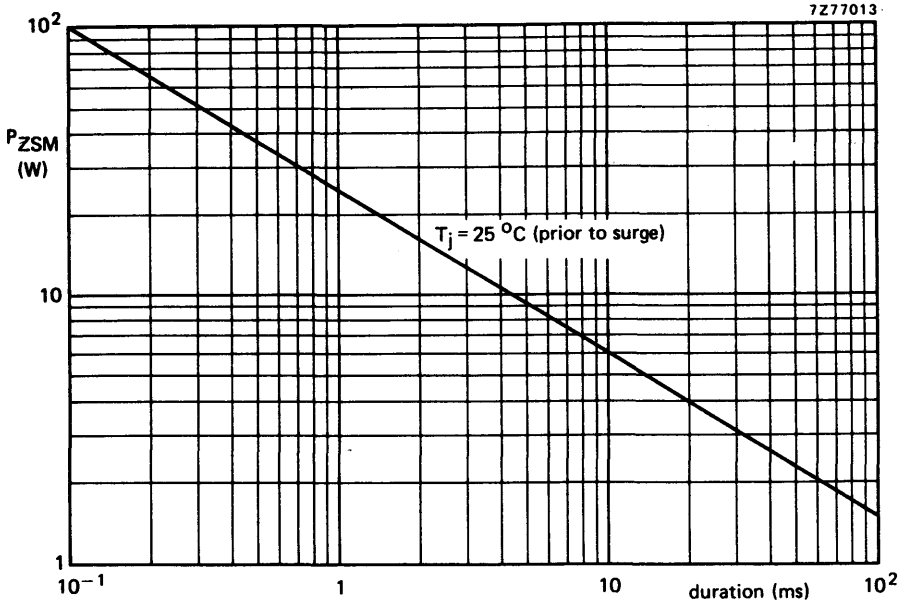

**BZX87
SERIES**

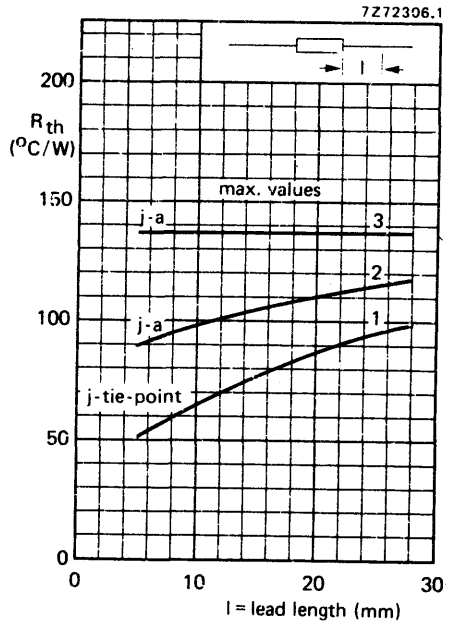
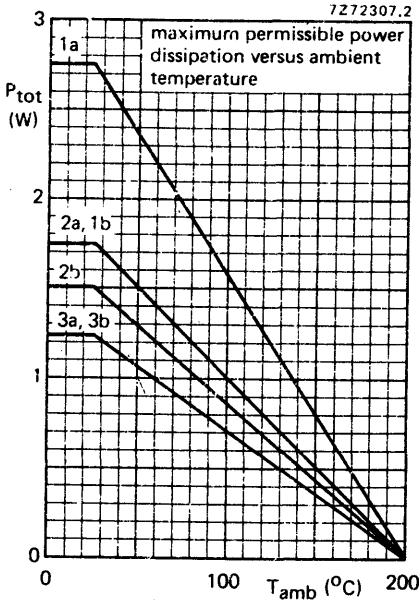

MOUNTING METHODS

1. to tie-points
 2. to solder tags
 3. on a printed-circuit board with minimum soldering area necessary for good electrical conductance
- a. lead length = 10 mm
 - b. at maximum lead length

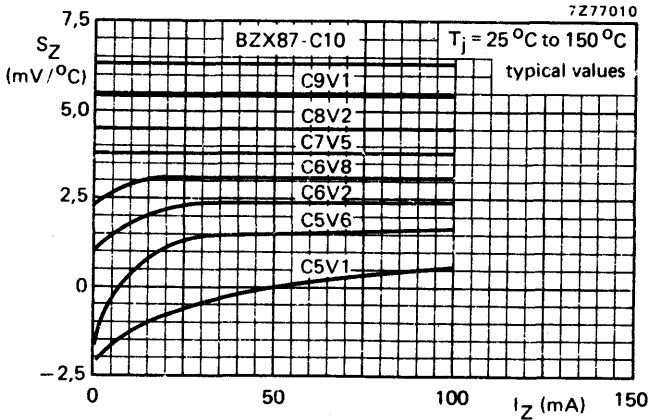

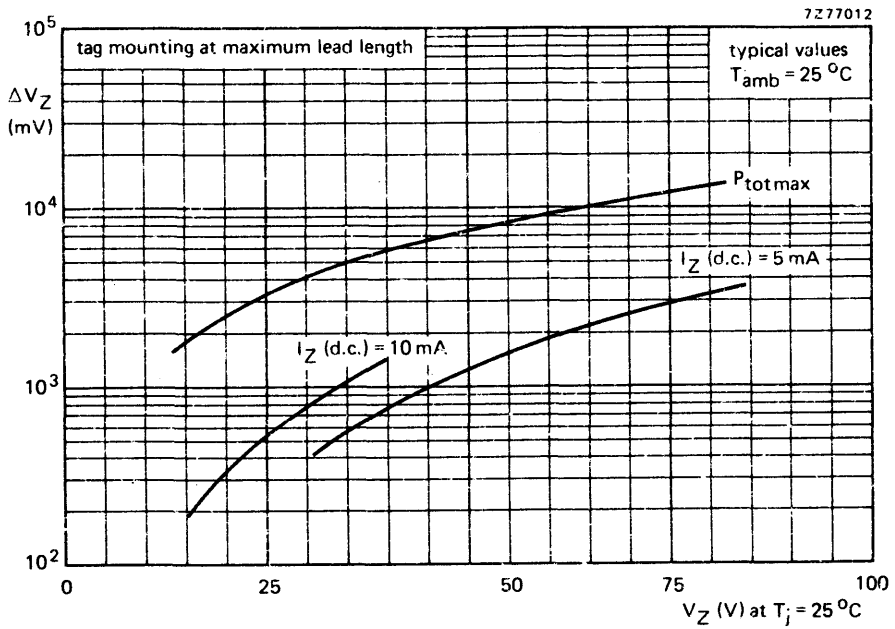
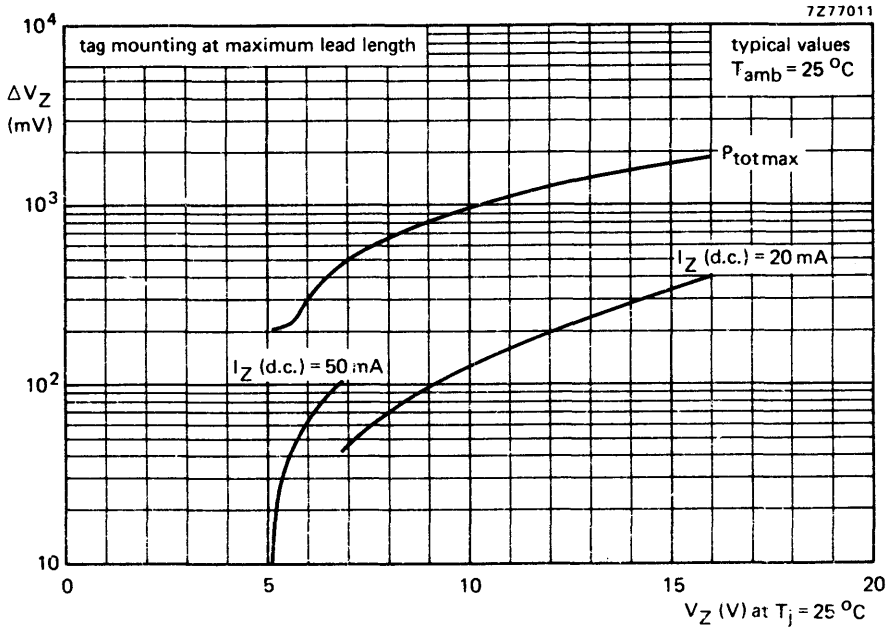

VOLTAGE REGULATOR DIODES

Silicon diodes in all-glass DO-7 envelope intended for voltage stabilization purposes. The series consists of 27 types with nominal working voltages ranging from 2,7 V to 33 V within the normalized E24 ($\pm 5\%$) range

QUICK REFERENCE DATA

Working voltage range	V_Z	nom.	2,7 to 33 V
Total power dissipation up to $T_{amb} = 50\text{ }^\circ\text{C}$	P_{tot}	max.	400 mW
Non-repetitive peak reverse power dissipation $T_j = 25\text{ }^\circ\text{C}$; $t = 10\text{ }\mu\text{s}$	P_{ZSM}	max.	1,1 kW
Operating junction temperature	T_j	max.	200 $^\circ\text{C}$
Thermal resistance from junction to ambient in free air	$R_{th\ j-a}$	=	0,37 $^\circ\text{C}/\text{mW}$

MECHANICAL DATA

Dimensions in mm

Fig. 1 DO-7.

The diodes are type-branded

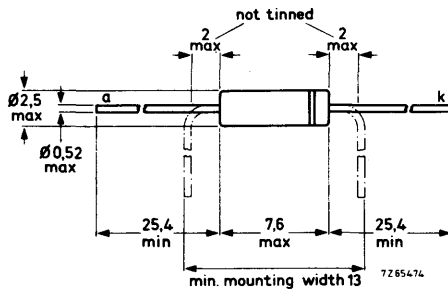

Cathode indicated by coloured band

For operation as a voltage regulator diode the positive voltage is connected to the lead adjacent to the white band.

Also available to BS 9305-N041, BS9305-F0087



Mullard

November 1979

1

RATINGS

Limiting values in accordance with the Absolute Maximum System (IEC 134)

Forward current (d.c.)	I_F	max.	250 mA
Repetitive peak forward current	I_{FRM}	max.	250 mA
Total power dissipation up to $T_{amb} = 50\text{ }^\circ\text{C}$	P_{tot}	max.	400 mW
Non-repetitive peak reverse power dissipation $T_j = 25\text{ }^\circ\text{C}; t = 10\text{ }\mu\text{s}$	P_{ZSM}	max.	1,1 kW
Storage temperature	T_{stg}		$-65\text{ to }+175\text{ }^\circ\text{C}$
Operating junction temperature	T_j	max.	200 $^\circ\text{C}$

THERMAL RESISTANCE

From junction to ambient in free air $R_{th\ j-a} = 0,37\text{ }^\circ\text{C/mW}$

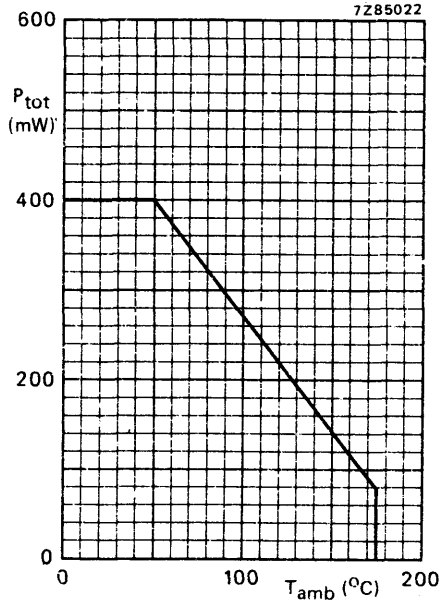

Fig. 2 Power derating curve.

CHARACTERISTICS

 $T_j = 25\text{ }^\circ\text{C}$ unless otherwise specified

Forward voltage

 $I_F = 10\text{ mA}$ $V_F < 0,9\text{ V}$

BZY88... .	working voltage V_Z at $I_Z = 1\text{ mA}$				temperature coefficient S_Z at $I_Z = 1\text{ mA}$				differential resistance r_{diff} at $I_Z = 1\text{ mA}$			
	min.	nom.	max.		min.	typ.	max.		min.	typ.	max.	
C2V7	1,9	2,15	2,4	V	-4,5	-1,7	-0,6	mV/°C	260	310	390	Ω
C3V0	2,1	2,4	2,7	V	-5,0	-1,8	-0,6	mV/°C	280	340	420	Ω
C3V3	2,4	2,75	3,0	V	-4,5	-1,9	-0,5	mV/°C	300	360	440	Ω
C3V6	2,7	3,0	3,3	V	-4,5	-2,05	-0,5	mV/°C	380	410	430	Ω
C3V9	3,0	3,3	3,6	V	-3,5	-2,4	-0,5	mV/°C	380	410	430	Ω
C4V3	3,3	3,6	3,9	V	-2,7	-2,25	-0,5	mV/°C	340	410	430	Ω
C4V7	3,7	4,1	4,3	V	-2,5	-2,0	-0,3	mV/°C	360	390	420	Ω
C5V1	4,3	4,65	5,0	V	-2,1	-1,9	-0,3	mV/°C	300	340	370	Ω
C5V6	4,8	5,3	5,7	V	-1,8	-1,4	0	mV/°C	160	310	350	Ω
C6V2	5,7	5,9	6,5	V	0	+1,6	+3,0	mV/°C	10	100	250	Ω
C6V8	6,3	6,7	6,9	V	+2	+3,2	+3,7	mV/°C	5,0	15	70	Ω
C7V5	7,0	7,45	7,8	V	+3	+4,2	+5,9	mV/°C	4,0	8,6	20	Ω
C8V2	7,8	8,1	8,5	V	+4,3	+5,0	+6,0	mV/°C	4,0	10	20	Ω
C9V1	8,55	9,0	9,5	V	+4,5	+6,0	+7,0	mV/°C	7,0	12	24	Ω
C10	9,3	9,9	10,5	V	+6,0	+6,6	+7,0	mV/°C	5,0	20	50	Ω
C11	10,3	10,9	11,5	V	+7,1	+8,3	+9,0	mV/°C	5,0	25	70	Ω
C12	11,3	11,9	12,5	V	+7,6	+8,7	+9,2	mV/°C	10	25	80	Ω
C13	12,3	12,9	13,0	V	+9,1	+10,1	+11,1	mV/°C	10	25	90	Ω
C15	13,8	14,9	15,5	V	+11	+12,5	+13	mV/°C	19	35	95	Ω
C16	15,3	15,8	16,9	V	+12	+13	+14	mV/°C	20	45	100	Ω
C18	16,7	17,8	18,9	V	+14	+15	+16,5	mV/°C	20	50	120	Ω
C20	18,7	19,8	21,0	V	+16	+17	+18,5	mV/°C	20	60	140	Ω
C22	20,6	21,8	23,1	V	+17	+19	+21	mV/°C	25	70	150	Ω
C24	22,5	23,8	25,7	V	+19	+21	+23	mV/°C	30	85	200	Ω
C27	24,7	26,6	28,5	V	+21	+22,5	+25	mV/°C	35	90	300	Ω
C30	27,5	29,5	31,5	V	+22	+24	+29	mV/°C	50	180	350	Ω
C33	29,5	32,5	34,5	V	+23	+26	+35	mV/°C	60	250	450	Ω

CHARACTERISTICS (continued)

$T_j = 25\text{ }^\circ\text{C}$ unless otherwise specified

BZY88-...	working voltage V_Z at $I_Z = 5\text{ mA}$			V	temperature coefficient S_Z at $I_Z = 5\text{ mA}$			mV/°C	differential resistance r_{diff} at $I_Z = 5\text{ mA}$			
	min.	nom.	max.		min.	typ.	max.		min.	typ.	max.	
C2V7	2,5	2,7	2,9	V	-4,0	-2,2	-0,6	mV/°C	68	80	120	Ω
C3V0	2,8	3,0	3,2	V	-4,5	-2,4	-0,6	mV/°C	70	84	120	Ω
C3V3	3,1	3,3	3,5	V	-4,0	-2,3	-0,5	mV/°C	70	86	110	Ω
C3V6	3,4	3,6	3,8	V	-3,5	-2,0	-0,5	mV/°C	65	76	105	Ω
C3V9	3,7	3,9	4,1	V	-2,5	-2,05	-0,5	mV/°C	60	76	100	Ω
C4V3	4,0	4,3	4,6	V	-2,5	-1,8	-0,5	mV/°C	55	70	90	Ω
C4V7	4,4	4,7	5,0	V	-2,0	-1,55	0	mV/°C	49	62	85	Ω
C5V1	4,8	5,1	5,4	V	-1,75	-1,2	0	mV/°C	34	46	75	Ω
C5V6	5,2	5,6	6,0	V	-1,5	-0,2	+1,0	mV/°C	10	22	55	Ω
C6V2	5,8	6,2	6,6	V	+0,5	+2,0	+3,5	mV/°C	1,0	7,0	27	Ω
C6V8	6,4	6,8	7,2	V	+2,3	+3,2	+3,8	mV/°C	0,5	3,0	15	Ω
C7V5	7,0	7,5	7,9	V	+3,1	+4,2	+5,9	mV/°C	0,5	3,0	15	Ω
C8V2	7,7	8,2	8,7	V	+4,2	+5,0	+6,0	mV/°C	0,9	3,5	20	Ω
C9V1	8,5	9,1	9,6	V	+4,8	+6,0	+7,0	mV/°C	1,0	4,75	25	Ω
C10	9,4	10	10,6	V	+6,0	+7,0	+7,5	mV/°C	2,0	5,0	25	Ω
C11	10,4	11	11,6	V	+7,0	+8,7	+9,1	mV/°C	3,0	7,0	25	Ω
C12	11,4	12	12,7	V	+8,5	+9,0	+9,6	mV/°C	4,0	8,0	35	Ω
C13	12,4	13	14,1	V	+10	+10,5	+11,5	mV/°C	4,0	10	35	Ω
C15	13,8	15	15,6	V	+12	+12,5	+14	mV/°C	4,0	15	35	Ω
C16	15,3	16	17,1	V	+12	+13	+14	mV/°C	5,0	20	40	Ω
C18	16,8	18	19,1	V	+14	+15	+18	mV/°C	7,0	25	45	Ω
C20	18,8	20	21,2	V	+16	+17	+19	mV/°C	10	30	50	Ω
C22	20,8	22	23,3	V	+17	+19	+21	mV/°C	15	35	60	Ω
C24	22,7	24	25,9	V	+20	+21	+24	mV/°C	20	40	75	Ω
C27	25,1	27	28,9	V	+22	+23,5	+27	mV/°C	25	50	85	Ω
C30	28	30	32	V	+25	+26	+29	mV/°C	30	60	95	Ω
C33	31	33	35	V	+27	+28	+36	mV/°C	35	75	120	Ω

BZY88. ...	working voltage V_Z at $I_Z = 20$ mA			V	temperature coefficient S_Z at $I_Z = 20$ mA			mV/°C	differential resistance r_{diff} at $I_Z = 20$ mA			
	min.	nom.	max.		min.	typ.	max.		min.	typ.	max.	
C2V7	3,0	3,25	3,5	V	-3,5	-2,4	-0,6	mV/°C	18	22	26	Ω
C3V0	3,3	3,6	3,9	V	-3,5	-2,5	-0,6	mV/°C	17	21	24	Ω
C3V3	3,5	4	4,2	V	-3,3	-2,4	-0,5	mV/°C	16	20	22	Ω
C3V6	3,9	4,2	4,4	V	-2,5	-1,55	-0,5	mV/°C	16	18	20	Ω
C3V9	4,2	4,45	4,65	V	-2,4	-1,55	-0,5	mV/°C	14	16	18	Ω
C4V3	4,45	4,7	4,95	V	-2,0	-1,5	-0,5	mV/°C	13	15	17	Ω
C4V7	4,9	5,1	5,3	V	-1,5	-0,85	0	mV/°C	12	15	17	Ω
C5V1	5,1	5,35	5,7	V	-1,5	-0,8	0	mV/°C	4,0	7,0	11	Ω
C5V6	5,45	5,75	6,1	V	-1,0	+1,0	+3,0	mV/°C	1,5	4,0	8,0	Ω
C6V2	5,95	6,4	6,7	V	+1,0	+2,2	+4,0	mV/°C	0,8	1,4	3,1	Ω
C6V8	6,6	6,9	7,25	V	+2,8	+3,2	+3,8	mV/°C	0,7	1,3	3,0	Ω
C7V5	7,2	7,65	7,95	V	+2,5	+4,2	+5,9	mV/°C	0,5	1,6	5,0	Ω
C8V2	7,9	8,4	8,75	V	+4,0	+5,0	+6,0	mV/°C	0,9	1,8	6,0	Ω
C9V1	8,7	9,4	9,7	V	+5,0	+6,0	+7,0	mV/°C	1,0	1,85	7,0	Ω
C10	9,5	10,1	10,8	V	+7,0	+7,3	+7,5	mV/°C	1,0	2,0	8,0	Ω
C11	10,5	11,1	11,8	V	+8,5	+9,1	+9,5	mV/°C	1,0	3,0	10	Ω
C12	11,6	12,2	12,8	V	+8,9	+9,6	+10,3	mV/°C	2,0	3,5	25	Ω
C13	12,6	13,2	14,3	V	+11	+11,5	+12,5	mV/°C	2,0	4,5	25	Ω
C15	14,1	15,3	15,9	V	+12	+13,5	+14,5	mV/°C	2,0	6,0	25	Ω
C16	15,6	16,3	17,4	V	+13	+14	+15	mV/°C	5,0	10	30	Ω
C18	17,2	18,4	19,6	V	+15	+16	+18	mV/°C	5,0	12	30	Ω
C20	19,3	20,5	21,9	V	+17,5	+18,5	+20,5	mV/°C	5,0	15	35	Ω
C22	21,3	22,6	24,1	V	+19	+20,5	+22,5	mV/°C	10	18	35	Ω
C24	23,3	24,7	26,7	V	+20	+23	+25	mV/°C	10	20	40	Ω
C27	25,8	28,1	30,1	V	+23	+25,5	+28	mV/°C	10	25	45	Ω
C30	29,0	31,3	33,4	V	+25	+28	+32	mV/°C	10	35	50	Ω
C33	32,0	34,5	36,6	V	+27	+30	+38	mV/°C	10	45	60	Ω

CHARACTERISTICS (continued)

$T_j = 25\text{ }^\circ\text{C}$ unless otherwise specified

BZY88...	typ. C_d $V_R = 3\text{ V}$	reverse current I_R			typ. noise voltage **			
		at $V_R =$	typ.	max.	$I_Z = 1\text{ mA}$	$I_Z = 5\text{ mA}$		
C2V7	490 pF *	1 V	4	25	μA	22	12	$\mu\text{V r.m.s.}$
C3V0	430 pF *	1 V	2	5	μA	20	11	$\mu\text{V r.m.s.}$
C3V3	380 pF *	1 V	0,51	3,0	μA	19	10	$\mu\text{V r.m.s.}$
C3V6	360 pF *	1 V	0,25	3,0	μA	18	9	$\mu\text{V r.m.s.}$
C3V9	335 pF	1 V	0,11	3,0	μA	16	8	$\mu\text{V r.m.s.}$
C4V3	270 pF	1 V	0,1	3,0	μA	15	8	$\mu\text{V r.m.s.}$
C4V7	290 pF	2 V	0,25	3,0	μA	14	7	$\mu\text{V r.m.s.}$
C5V1	275 pF	2 V	0,15	1,0	μA	13	8	$\mu\text{V r.m.s.}$
C5V6	260 pF	2 V	0,6	1,0	μA	13	9	$\mu\text{V r.m.s.}$
C6V2	240 pF	2 V	0,1	1,0	μA	14	10	$\mu\text{V r.m.s.}$
C6V8	220 pF	3 V	0,025	1,0	μA	25	15	$\mu\text{V r.m.s.}$
C7V5	190 pF	3 V	15	500	nA	33	20	$\mu\text{V r.m.s.}$
C8V2	150 pF	3 V	11	400	nA	55	28	$\mu\text{V r.m.s.}$
C9V1	140 pF	5 V	8	400	nA	79	35	$\mu\text{V r.m.s.}$
C10	110 pF	7 V	—	2,5	μA	87	43	$\mu\text{V r.m.s.}$
C11	90 pF	7 V	—	2,5	μA	92	48	$\mu\text{V r.m.s.}$
C12	80 pF	8 V	—	2,5	μA	100	50	$\mu\text{V r.m.s.}$
C13	65 pF	9 V	—	2,5	μA	110	52	$\mu\text{V r.m.s.}$
C15	60 pF	10 V	—	2,5	μA	120	54	$\mu\text{V r.m.s.}$
C16	55 pF	10 V	—	2,5	μA	135	56	$\mu\text{V r.m.s.}$
C18	50 pF	13 V	—	2,5	μA	160	58	$\mu\text{V r.m.s.}$
C20	45 pF	14 V	—	2,5	μA	210	60	$\mu\text{V r.m.s.}$
C22	43 pF	15 V	—	2,5	μA	255	62	$\mu\text{V r.m.s.}$
C24	42 pF	17 V	—	2,5	μA	290	65	$\mu\text{V r.m.s.}$
C27	40 pF	19 V	—	2,5	μA	320	69	$\mu\text{V r.m.s.}$
C30	35 pF	21 V	—	2,5	μA	350	73	$\mu\text{V r.m.s.}$
C33	32 pF	23 V	—	2,5	μA	380	78	$\mu\text{V r.m.s.}$

* Diode capacitance at $V_R = 2\text{ V}$.

** Noise voltage measured using a bandwidth $\pm 3\text{ dB}$ of 10 Hz to 50 kHz.

OPERATING NOTES

1. Dissipation and heatsink considerations

a. Steady-state conditions

The maximum allowable steady-state dissipation $P_{S \max}$ is given by the relationship

$$P_{S \max} = \frac{T_{j \max} - T_{\text{amb}}}{R_{\text{th } j-a}}$$

where: $T_{j \max}$ is the maximum permissible operating junction temperature;
 T_{amb} is the ambient temperature;
 $R_{\text{th } j-a}$ is the total thermal resistance from junction to ambient.

b. Pulse conditions (see Fig. 3)

The maximum allowable additional pulse power $P_{m \max}$ is given by the formula

$$P_{m \max} = \frac{(T_{j \max} - T_{\text{amb}}) - (P_s \cdot R_{\text{th } j-a})}{Z_{\text{th}}}$$

where: P_s is the steady-state dissipation, excluding that in the pulses;
 Z_{th} is the effective transient thermal resistance of the device from junction to ambient. It is a function of the pulse duration t and duty factor δ (see Fig. 9);
 δ is the duty factor and is equal to the pulse duration t divided by the periodic time T .

The steady-state power P_s when biased in the zener direction at a given zener current can be found from Fig. 18. With the additional pulsed power dissipation $P_{m \max}$ calculated from the above expression, the total repetitive peak zener power dissipation $P_{ZRM} = P_s + P_{m \max}$. From Fig. 18 the corresponding maximum repetitive peak zener current at P_{ZRM} can now be read. For pulse durations longer than the temperature stabilization time of the diode t_{stab} , the maximum allowable repetitive peak dissipation P_{ZRM} is equal to the maximum steady-state power $P_{S \max}$. The temperature stabilization for the BZY88series is 100 s (see Fig. 9).

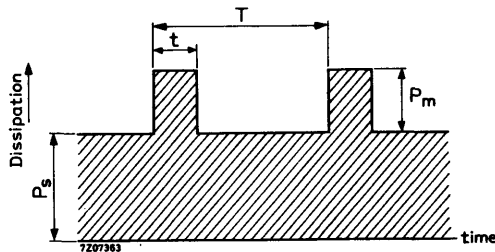

Fig. 3.

OPERATING NOTES (continued)

Example

The following example illustrates how to calculate the maximum permissible repetitive peak zener current of a BZY88-C7V5 zener diode mounted in free air at a maximum ambient temperature of 60 °C. The steady-state zener current is 10 mA, the duty factor $\delta = 0,1$ and the pulse duration $t = 1$ ms.

The steady-state dissipation P_s at a zener current is 10 mA (from Fig. 18) = 76 mW.

The thermal resistance from junction to ambient $R_{th\ j-a} = 0,31$ °C/mW.

The thermal impedance Z_{th} with a duty factor $\delta = 0,1$ and a pulse duration $t = 1$ ms (from Fig. 9).

$$Z_{th} = 41,5 \text{ °C/W.}$$

The maximum additional pulse power dissipation

$$P_{m\ max} = \frac{(T_j\ max - T_{amb}) - P_s \cdot R_{th\ j-a}}{Z_{th}}$$

If $P_s = 76$ mW, $Z_{th} = 41,5$ °C/W,

$$P_{m\ max} = \frac{(200-60) - (0,076 \times 310)}{41,5} = 2,8 \text{ W}$$

therefore, the total repetitive peak power dissipation,

$$P_{ZRM} = 0,076 + 2,8 = 2,88 \text{ W.}$$

From Fig. 18 the corresponding repetitive peak zener current is 350 mA.

2. Zener characteristics

The basic characteristic of a zener diode is the dynamic zener characteristic, that is, the variation of zener voltage when a current pulse is applied in the reverse direction. The slope of this characteristic is r_z . Typical dynamic characteristics at $T_j = 25$ and 150 °C are given on pages 12 and 13 for each type of diode. Because of the temperature sensitivity of the zener characteristics, the dynamic characteristics at any other operating temperature will be displaced from those at $T_j = 25$ °C by a voltage corresponding to $S_Z \times (T_n - 25)$ °C, where S_Z is the temperature coefficient of the diode and T_n is a nominal operating temperature (Figs 4 and 5).

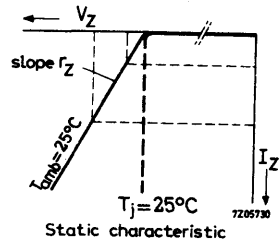
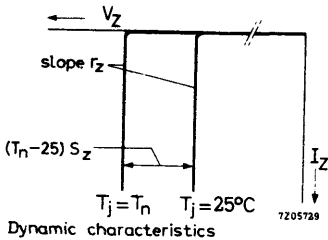

Fig. 4 Dynamic characteristics.

Fig. 5 Static characteristics.

The static characteristic of the diode is obtained by connecting the steady-state zener voltages at various direct zener currents and may, therefore, be used to determine the operating point at any zener current. This is shown above. The slope of the static characteristic will depend on

- (1) the differential resistance, r_z ;
- (2) the rise in junction temperature due to internal dissipation and the thermal resistance from junction to ambient, $V_Z \cdot I_Z \cdot R_{th\ j-a}$;
- (3) the temperature coefficient of the diode, S_Z .

From the above, the static slope resistance r_Z is found to be

$$r_Z = r_z + V_Z \cdot R_{th\ j-a} \cdot S_Z$$

where r_z is the differential resistance, V_Z is the steady-state zener voltage and is equal to

$$\frac{V_Z'}{1 - I_Z \cdot R_{th\ j-a} \cdot S_Z}$$

V_Z' being the zener voltage at $T_j = T_n$ at the working current I_Z .

The position of this static characteristic in relation to the dynamic characteristic at $T_j = 25^\circ\text{C}$ is dependent on the ambient temperature and the temperature coefficient, the low-current voltage being displaced by

$$S_Z \times (T_n - 25)^\circ\text{C}$$

from the low current voltage, V_{ZO} on the dynamic characteristic at $T_j = 25^\circ\text{C}$ (see Fig. 6).

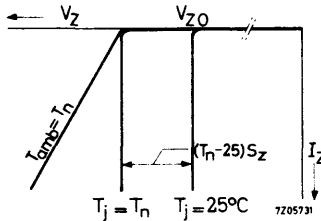

Fig. 6 Example for positive S_Z .

OPERATING NOTES (continued)

Figure 7 shows typical dynamic characteristics at $T_j = 25, 150$ and a nominal temperature, T_n °C. It also shows static characteristics at ambient temperatures of 25 and T_n °C.

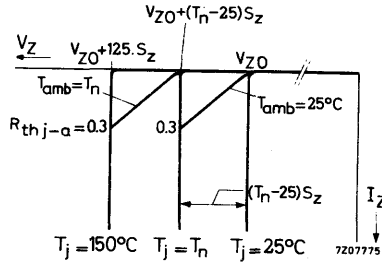

Fig. 7 Example for positive S_Z .

Typical static characteristics for each type of diode are given on page 14. These curves were obtained with the device mounted in free air at an ambient temperature of 25 °C.

The slope resistance for pulse operation can be calculated by incorporating the thermal impedance Z_{th} into the formula for r_Z . Curves of Z_{th} plotted against pulse duration and duty factor are given in Fig. 9.

3. When using a soldering iron, the diode may be soldered directly into a circuit, but heat conducted to the junction should be kept to a minimum by use of a thermal shunt.
4. Diodes may be dip-soldered at a solder temperature of 245 °C for a maximum soldering time of 5 seconds. The case temperature during dip-soldering must not at any time exceed the maximum storage temperature. These recommendations apply to a diode with the anode end mounted flush on the board with punched-through holes. For mounting the cathode end onto the board the diode must be spaced 5 mm from the underside of the printed circuit board in the case of punched-through holes or 5 mm from the top of the board for plated-through holes.
5. Care should be taken not to bend the leads nearer than 1,5 mm from the seals.

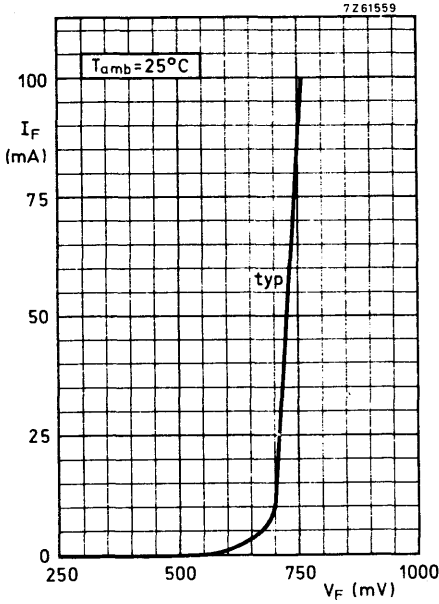

Fig. 8.

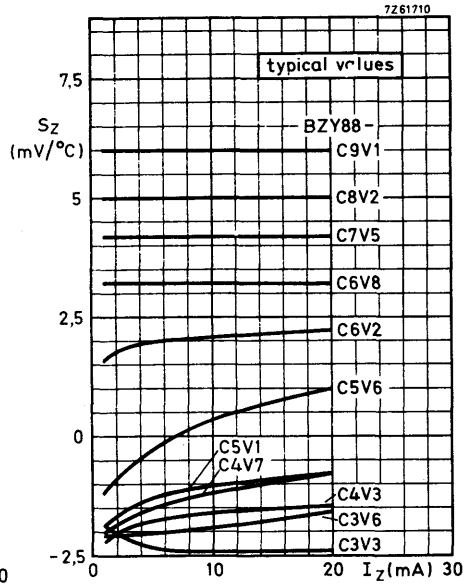

Fig. 9.

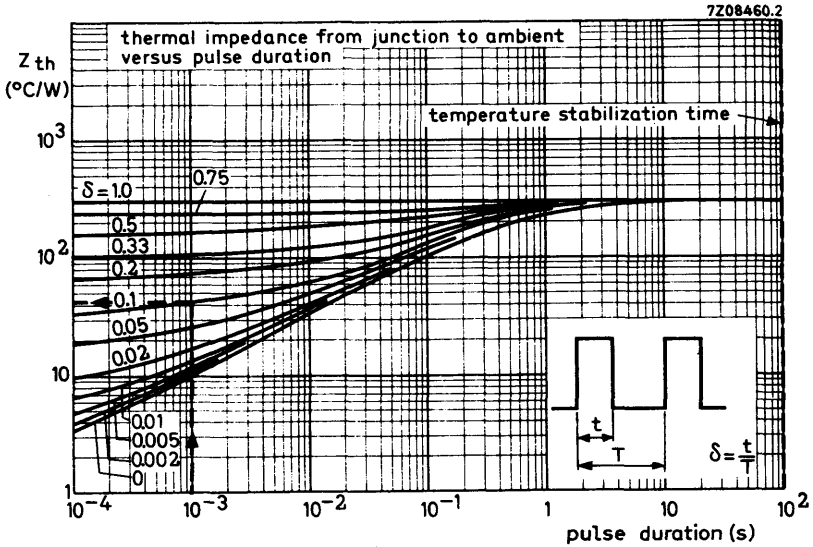

Fig. 10.

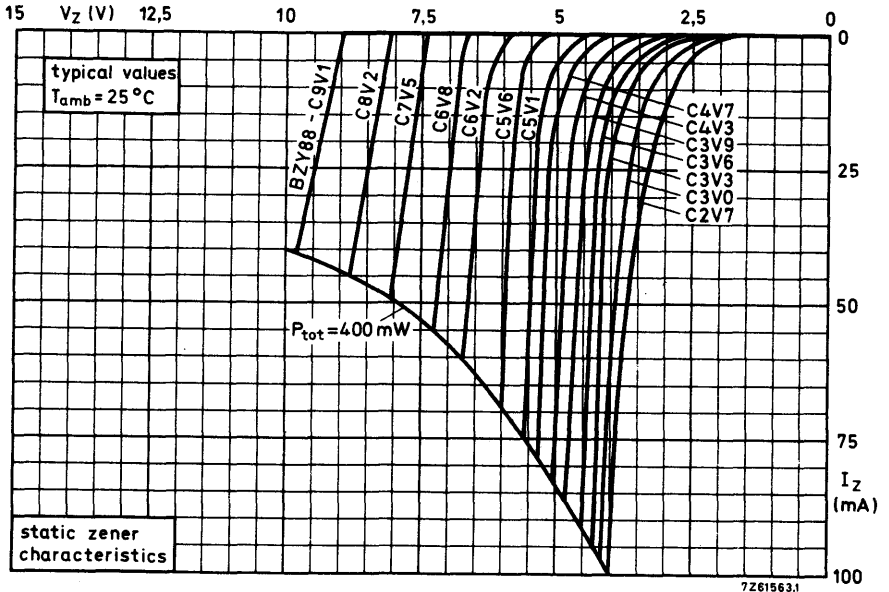

Fig. 11.

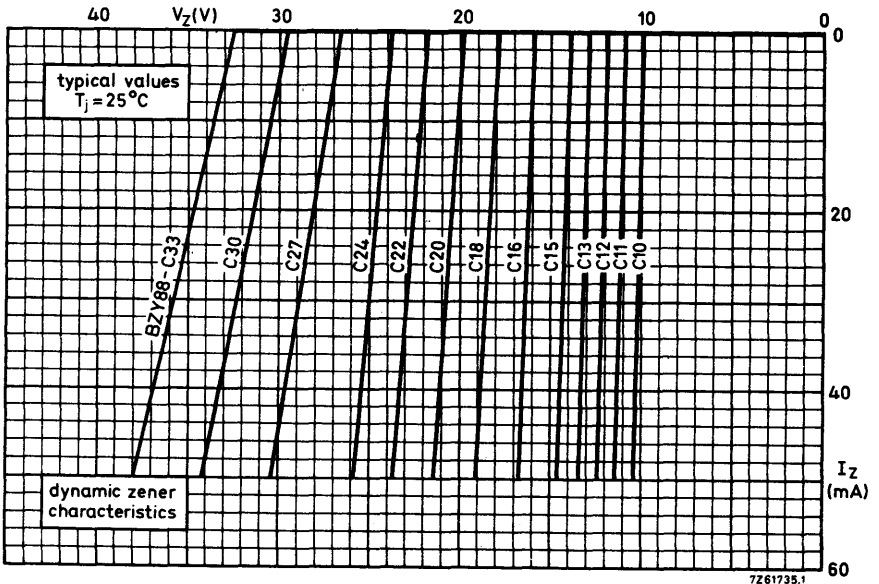

Fig. 12.

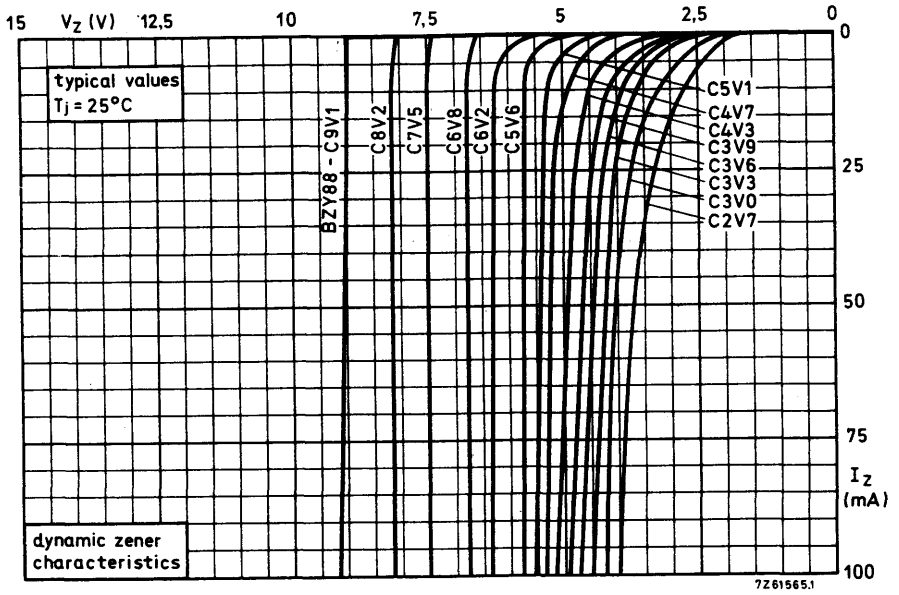

Fig. 13.

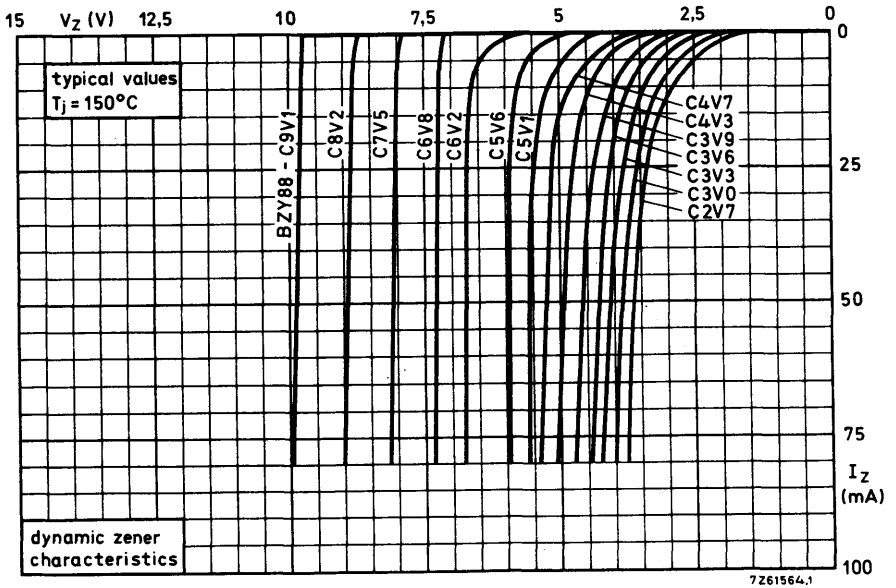

Fig. 14.

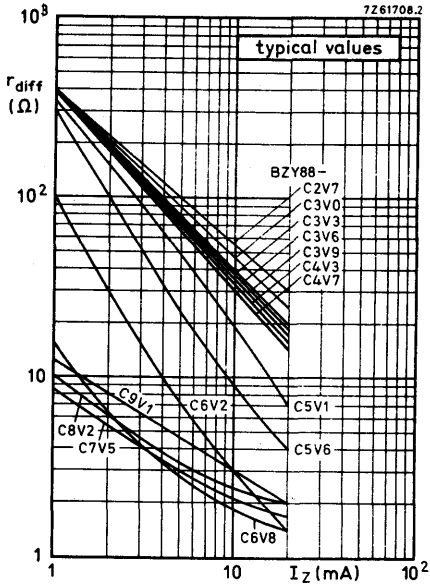

Fig. 15.

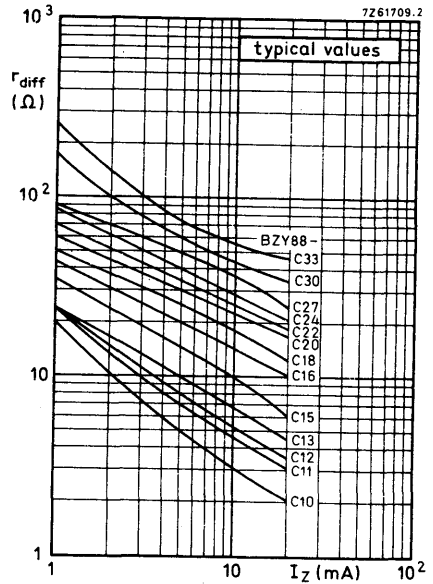

Fig. 16.

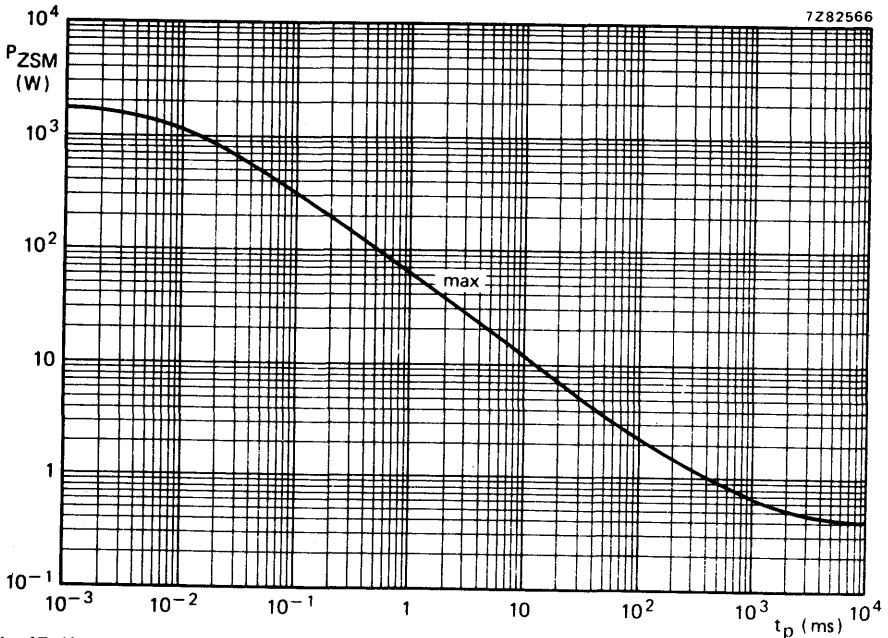

Fig. 17 Non-repetitive surge pulse power as a function of pulse duration. Rectangular pulse: 2 pulses per minute; $T_j = 25^\circ\text{C}$.

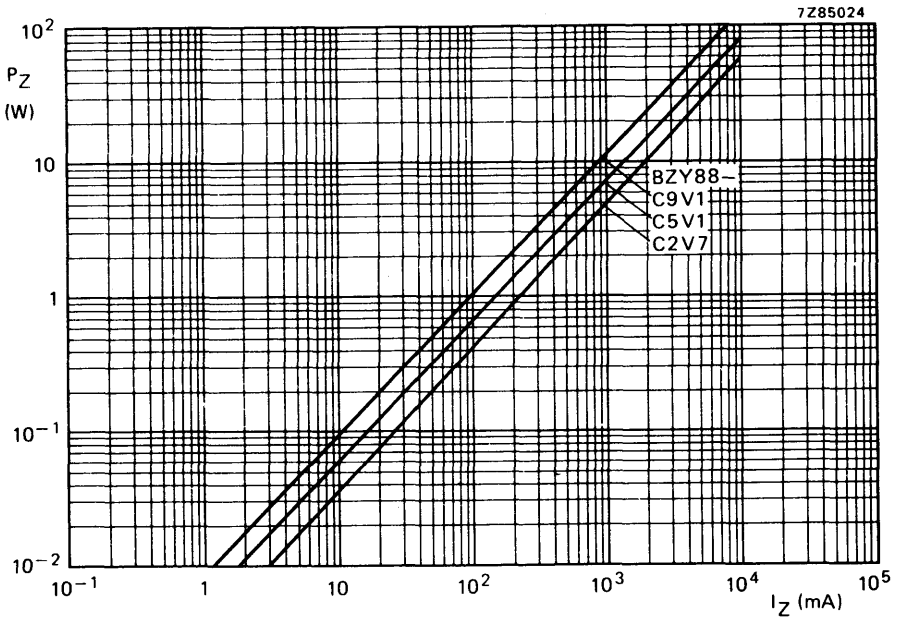

Fig. 18.

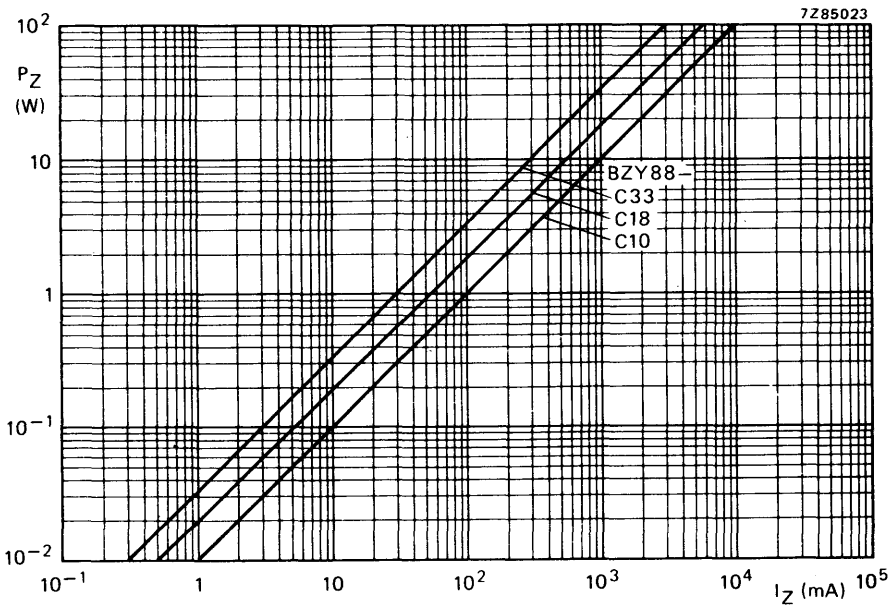

Fig. 19.

VOLTAGE REFERENCE DIODES





VOLTAGE REFERENCE DIODES

The BZV10 to 14 are temperature compensated voltage reference diodes in a DO-35 envelope. They are primarily intended for use as voltage reference sources in measuring instruments such as digital voltmeters.

QUICK REFERENCE DATA				
		min.	nom.	max.
Reference voltage at $I_Z = 2,0 \text{ mA}$	V_{ref}	6,175	6,5	6,825 V
Reference voltage excursion at $I_Z = 2,0 \text{ mA}$				
Ambient temperature test points: 0; +25 °C and +70 °C	<u>BZV10</u>	$ \Delta V_{\text{ref}} $	< 46,0	mV
	<u>BZV11</u>	$ \Delta V_{\text{ref}} $	< 23,0	mV
(see notes 1 and 2 on page 3 and the graph on page 4)	<u>BZV12</u>	$ \Delta V_{\text{ref}} $	< 9,0	mV
	<u>BZV13</u>	$ \Delta V_{\text{ref}} $	< 4,6	mV
	<u>BZV14</u>	$ \Delta V_{\text{ref}} $	< 2,3	mV
Operating ambient temperature	T_{amb}	0 to +70		°C

MECHANICAL DATA

Dimensions in mm

DO-35

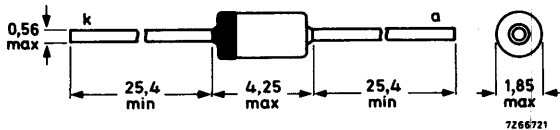

Cathode indicated by coloured band
The diodes are type-branded



RATINGS Limiting values in accordance with the Absolute Maximum System (IEC134)

Currents

Working current (d. c.)	I_Z	max.	50	mA
Working current (peak value)	I_{ZM}	max.	50	mA

Power dissipation

Total power dissipation up to $T_{amb} = 50\text{ }^\circ\text{C}$	P_{tot}	max.	400	mW
--	-----------	------	-----	----

Temperatures

Storage temperature	T_{stg}	-65 to +200	$^\circ\text{C}$
Operating ambient temperature	T_{amb}	0 to +70	$^\circ\text{C}$

THERMAL RESISTANCE

From junction to ambient in free air	$R_{th\ j-a}$	=	0,375	$^\circ\text{C}/\text{mW}$
--------------------------------------	---------------	---	-------	----------------------------

CHARACTERISTICS

$T_{amb} = 25\text{ }^\circ\text{C}$ unless otherwise specified

<u>Reference voltage</u> at $I_Z = 2,0\text{ mA}$	V_{ref}	<u>min.</u>	<u>nom.</u>	<u>max.</u>	V
		6,175	6,5	6,825	

Reference voltage excursion at $I_Z = 2,0\text{ mA}$

Ambient temperature test points: 0; +25 $^\circ\text{C}$ and +70 $^\circ\text{C}$	<u>BZV10</u>	$ \Delta V_{ref} $	<	46,0	mV
(see notes 1 and 2 on the next page and the graph on page 4)	<u>BZV11</u>	$ \Delta V_{ref} $	<	23,0	mV
	<u>BZV12</u>	$ \Delta V_{ref} $	<	9,0	mV
	<u>BZV13</u>	$ \Delta V_{ref} $	<	4,6	mV
	<u>BZV14</u>	$ \Delta V_{ref} $	<	2,3	mV

Temperature coefficient at $I_Z = 2,0\text{ mA}$

(see notes 1 and 2 on the next page and the graph on page 4)	<u>BZV10</u>	S_Z	$\pm 0,01$	$\% / ^\circ\text{C}$
	<u>BZV11</u>	S_Z	$\pm 0,005$	$\% / ^\circ\text{C}$
	<u>BZV12</u>	S_Z	$\pm 0,002$	$\% / ^\circ\text{C}$
	<u>BZV13</u>	S_Z	$\pm 0,001$	$\% / ^\circ\text{C}$
	<u>BZV14</u>	S_Z	$\pm 0,0005$	$\% / ^\circ\text{C}$

Differential resistance at $I_Z = 2,0\text{ mA}$

r_{diff}	typ.	30	Ω
	<	50	Ω

Note 1 I_Z tolerance and stability of I_Z .

The quoted values of ΔV_{ref} are based on a constant current I_Z . Two factors can cause V_{ref} to change, namely the differential resistance r_{diff} and the temperature coefficient S_Z .

- a As the max. r_{diff} of the device can be 50Ω , a change of $0,01 \text{ mA}$ in the current through the reference diode will result in a ΔV_{ref} of $0,01 \text{ mA} \times 50 \Omega = 0,5 \text{ mV}$. This level of ΔV_{ref} is not significant on a BZV10 ($\Delta V_{\text{ref}} < 46 \text{ mV}$), it is however very significant on a BZV14 ($\Delta V_{\text{ref}} < 2,3 \text{ mV}$).
- b The temperature coefficient of the reference voltage S_Z is a function of I_Z . Reference diodes are classified at the specified test current and the S_Z of the reference diode will be different at different levels of I_Z . The absolute value of I_Z is important, however, the stability of I_Z , once the level has been set, is far more significant. This applies particularly to the BZV13 and BZV14. The effect of I_Z stability on S_Z is shown in the graph on page 4.

Note 2 Voltage excursion (ΔV_{ref} and temperature coefficient).

All reference diodes are characterized by the 'box method'. This guarantees a maximum voltage excursion (ΔV_{ref}) over the specified temperature range, at the specified test current (I_Z), verified by tests at indicated temperature points within the range. V_Z is measured and recorded at each temperature specified. The ΔV_{ref} between the highest and lowest values must not exceed the maximum ΔV_{ref} given. The temperature coefficient, therefore is given only as a reference; but may be derived from:

$$S_Z = \frac{(V_{\text{ref}1} - V_{\text{ref}2}) \times 100}{(T_{\text{amb}2} - T_{\text{amb}1}) \times V_{\text{ref nom}}} \% / ^\circ\text{C}$$

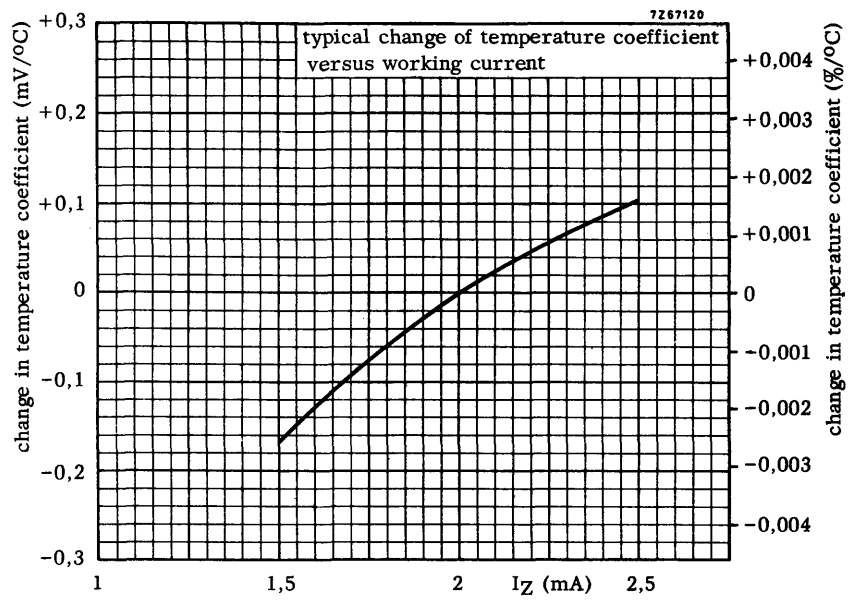
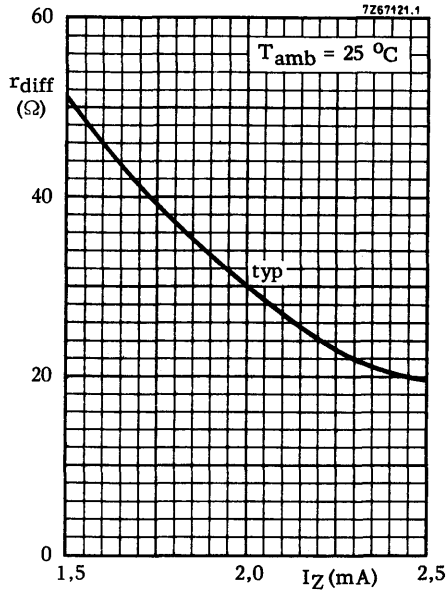

VOLTAGE REFERENCE DIODES

Voltage reference diodes in a whiskerless glass envelope. They have a very low temperature coefficient and are primarily intended for use as reference sources.

QUICK REFERENCE DATA

		min.	typ.	max.	
Reference voltage at $I_Z = 7,5 \text{ mA}$	V_{ref}	6,2	6,5	6,8	V
Temperature coefficient at $I_Z = 7,5 \text{ mA}$ *	BZX90:	$ S_Z <$	0,01		%/°C
	BZX91:	$ S_Z <$	0,005		%/°C
	BZX92:	$ S_Z <$	0,002		%/°C
	BZX93:	$ S_Z <$	0,001		%/°C
	BZX94:	$ S_Z <$	0,0005		%/°C
Operating ambient temperature	T_{amb}	-55 to +100			°C

MECHANICAL DATA

Dimensions in mm

Fig. 1 SOD-27 (DO-35).

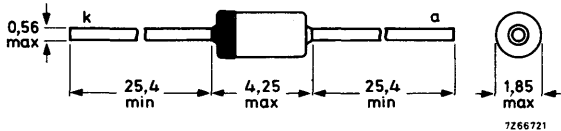

Cathode indicated by coloured band; the diodes are type branded.

* For accuracy of I_Z see graphs on page 5.



RATINGS

Limiting values in accordance with the Absolute Maximum System (IEC 134)

Working current (d.c.)	I_Z	max.	50	mA
Working current (peak value)	I_{ZM}	max.	50	mA
Total power dissipation up to $T_{amb} = 50\text{ }^\circ\text{C}$	P_{tot}	max.	400	mW
Storage temperature	T_{stg}		-65 to +200	$^\circ\text{C}$
Operating ambient temperature	T_{amb}		-55 to +100	$^\circ\text{C}$

THERMAL RESISTANCE

From junction to ambient in free air	$R_{th\ j-a}$	=	0,4	$^\circ\text{C}/\text{mW}$
--------------------------------------	---------------	---	-----	----------------------------

CHARACTERISTICS

$T_{amb} = 25\text{ }^\circ\text{C}$ unless otherwise specified

		min.	nom.	max.
Reference voltage at $I_Z = 7,5\text{ mA}$	V_{ref}	6,2	6,5	6,8
		V		

Reference voltage excursion at $I_Z = 7,5\text{ mA}^*$

$T_{amb} = -55\text{ to } +100\text{ }^\circ\text{C}$

BZX90:	$ \Delta V_{ref} $	<	100	mV
BZX91:	$ \Delta V_{ref} $	<	50	mV
BZX92:	$ \Delta V_{ref} $	<	20	mV
BZX93:	$ \Delta V_{ref} $	<	10	mV
BZX94:	$ \Delta V_{ref} $	<	5	mV

Temperature coefficient at $I_Z = 7,5\text{ mA}^*$

$T_{amb} = -55\text{ to } +100\text{ }^\circ\text{C}$

BZX90:	$ S_Z $	<	0,01	%/ $^\circ\text{C}$
BZX91:	$ S_Z $	<	0,005	%/ $^\circ\text{C}$
BZX92:	$ S_Z $	<	0,002	%/ $^\circ\text{C}$
BZX93:	$ S_Z $	<	0,001	%/ $^\circ\text{C}$
BZX94:	$ S_Z $	<	0,0005	%/ $^\circ\text{C}$

Differential resistance at $I_Z = 7,5\text{ mA}$

r_{diff}	<	15	Ω
------------	---	----	----------

NOTE

The temperature coefficient (S_Z) of the reference voltage (V_{ref}) is obtained from the following equation:

$$S_Z = \frac{V_{ref1} - V_{ref2}}{(T_{amb2} - T_{amb1}) \times V_{ref\ nom}} \times 100\text{ } \%/^\circ\text{C}$$

* For accuracy of I_Z see graphs on page 5.

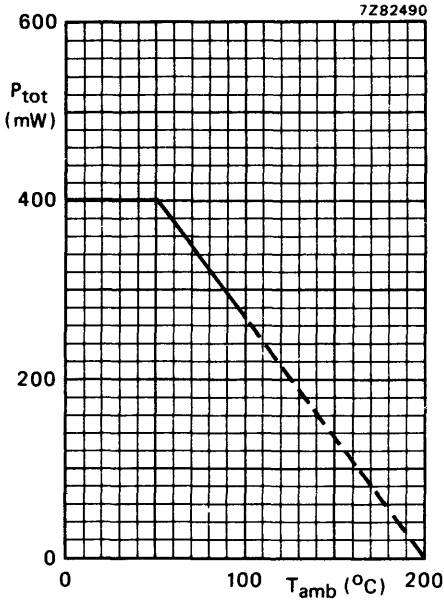

Fig. 2.

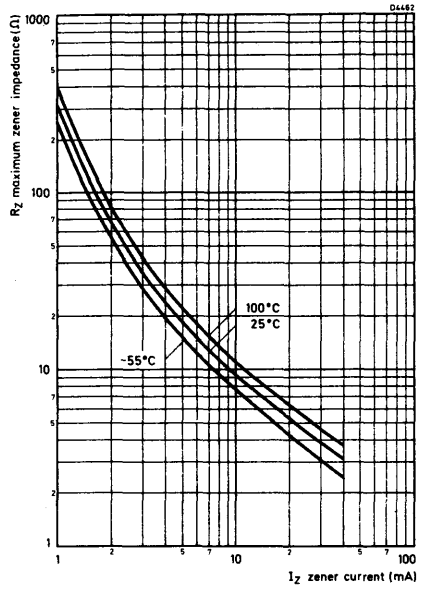

Fig. 3.

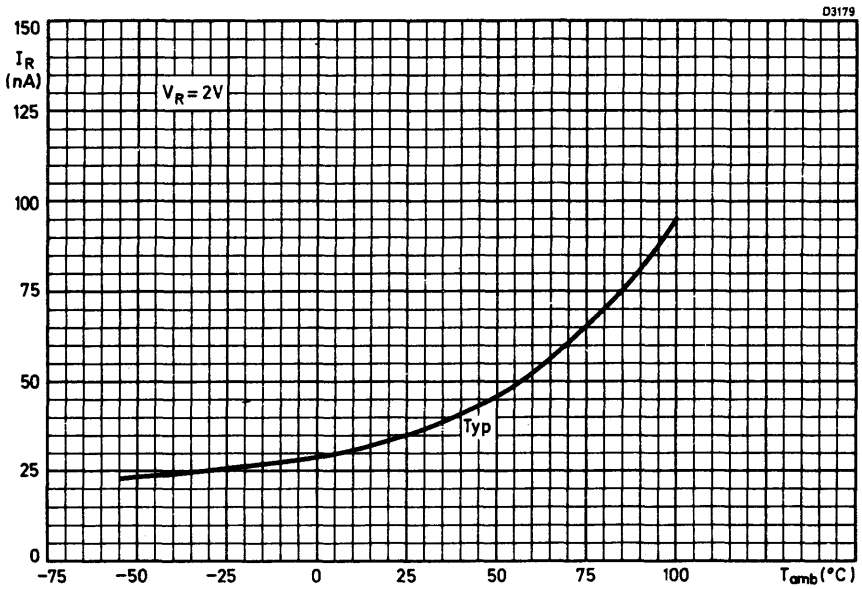

Fig. 4.

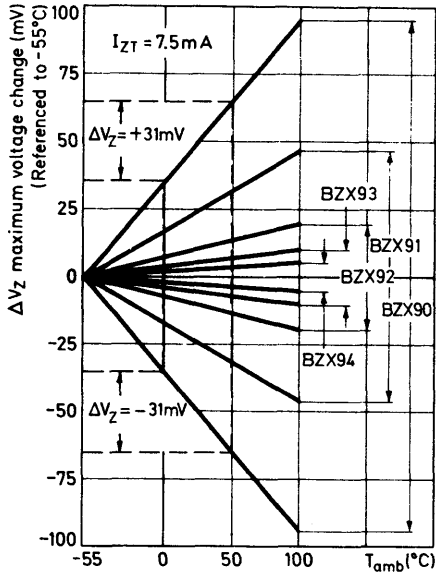

Fig. 5.

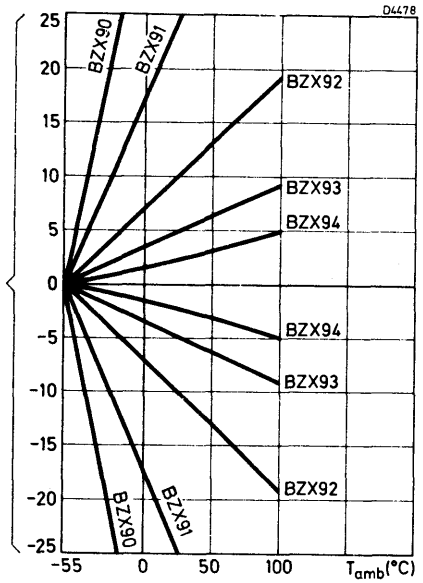

Fig. 6.

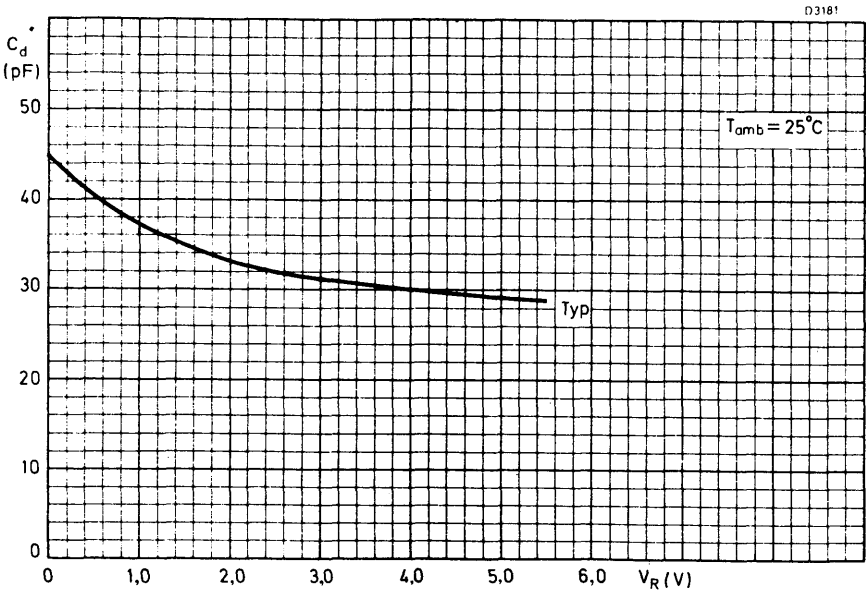

Fig. 7.

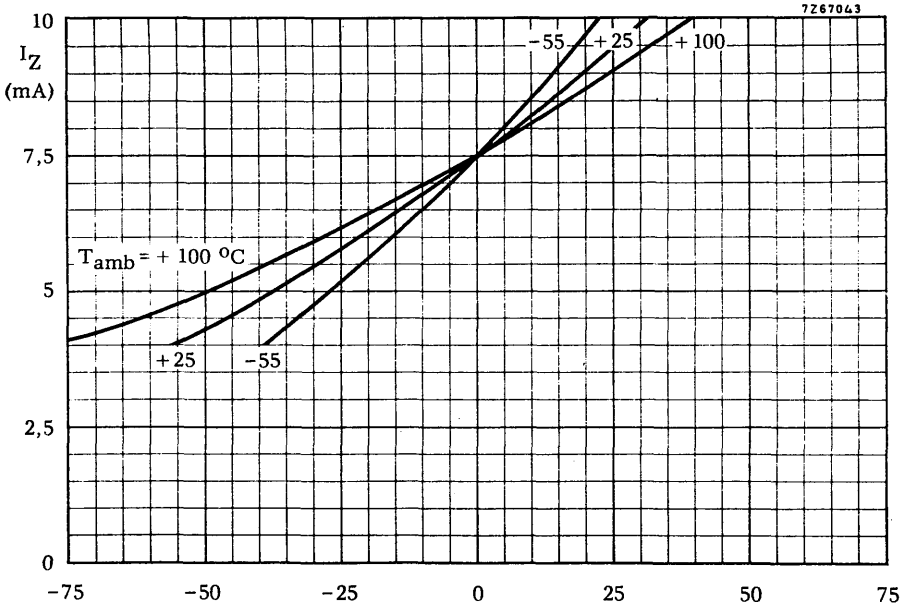

Fig. 8 Max. ΔV_{ref} (mV) (referenced to $I_Z = 7,5$ mA).

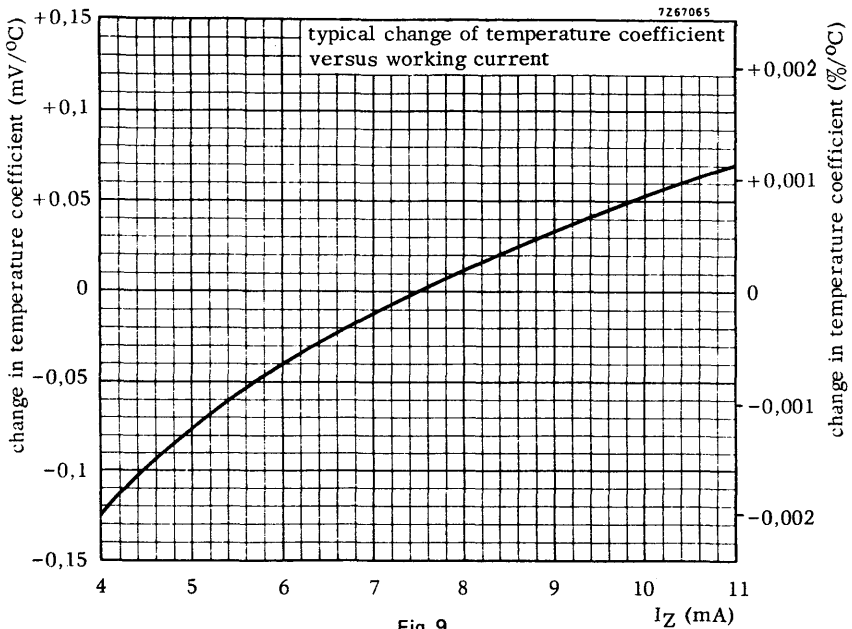

Fig. 9.

D3178

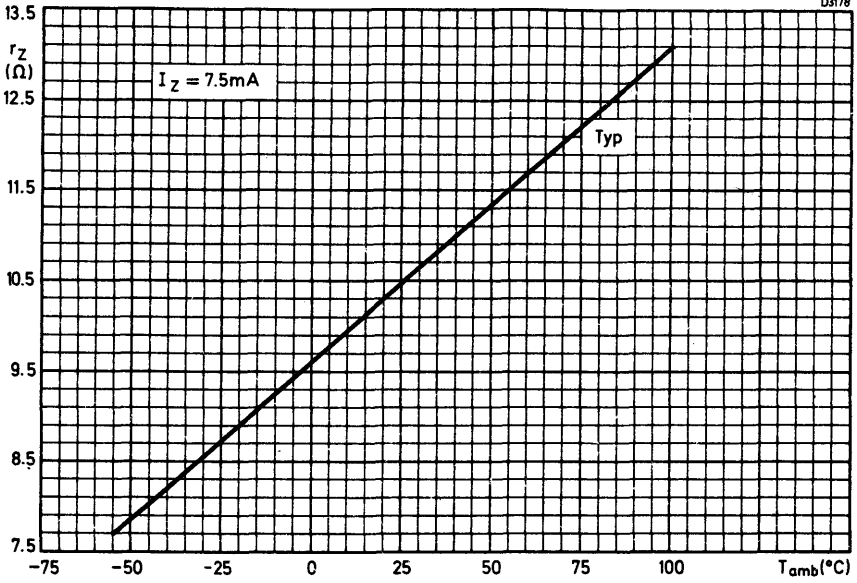

Fig. 10.

VOLTAGE REFERENCE DIODES

Voltage reference diodes in a DO-35 envelope. They have a very low temperature coefficient and are primarily intended for use as voltage reference sources in measuring instruments such as digital voltmeters.

QUICK REFERENCE DATA					
		min.	nom.	max.	
Reference voltage at $I_Z = 7,5 \text{ mA}$	V_{ref}	5,89	6,20	6,51	V
Reference voltage excursion at $I_Z = 7,5 \text{ mA}$ ¹⁾					
(see notes 1 and 2 on page 3 and the graphs on pages 4 and 5)	1N821	$ \Delta V_{\text{ref}} $	< 96		mV
	1N823	$ \Delta V_{\text{ref}} $	< 48		mV
	1N825	$ \Delta V_{\text{ref}} $	< 19		mV
	1N827	$ \Delta V_{\text{ref}} $	< 9		mV
	1N829	$ \Delta V_{\text{ref}} $	< 5		mV
Operating ambient temperature	T_{amb}	-55 to +100			°C

MECHANICAL DATA

Dimensions in mm

DO-35

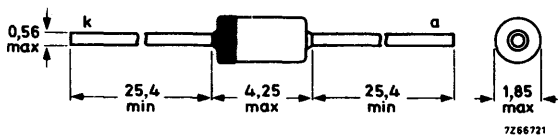

Cathode indicated by coloured band
The diodes are type-branded

1) For accuracy of I_Z see graphs on pages 4 and 5.



RATINGS Limiting values in accordance with the Absolute Maximum System (IEC134)

Currents

Working current (d. c.)	I_Z	max.	50	mA
Working current (peak value)	I_{ZM}	max.	50	mA

Power dissipation

Total power dissipation up to $T_{amb} = 50\text{ }^\circ\text{C}$	P_{tot}	max.	400	mW
--	-----------	------	-----	----

Temperatures

Storage temperature	T_{stg}	-65 to +200	$^\circ\text{C}$
Operating ambient temperature	T_{amb}	-55 to +100	$^\circ\text{C}$

THERMAL RESISTANCE

From junction to ambient in free air	$R_{th\ j-a}$	=	0,375	$^\circ\text{C}/\text{mW}$
--------------------------------------	---------------	---	-------	----------------------------

CHARACTERISTICS

$T_j = 25\text{ }^\circ\text{C}$ unless otherwise specified

<u>Reference voltage</u> at $I_Z = 7,5\text{ mA}$	V_{ref}	<u>min.</u>	<u>nom.</u>	<u>max.</u>	V
		5,89	6,20	6,51	

Reference voltage excursion at $I_Z = 7,5\text{ mA}$ 1)

ambient temperature test points: -55; +25; +75; +100 $^\circ\text{C}$ (see notes 1 and 2 on the next page and the graphs on pages 4 and 5)	1N821	$ \Delta V_{ref} <$	96	mV
	1N823	$ \Delta V_{ref} <$	48	mV
	1N825	$ \Delta V_{ref} <$	19	mV
	1N827	$ \Delta V_{ref} <$	9	mV
	1N829	$ \Delta V_{ref} <$	5	mV

Effective temperature coefficient at $I_Z = 7,5\text{ mA}$ 1)

(see notes 1 and 2 on the next page and the graphs on pages 4 and 5)	1N821	S_Z	$\pm 0,01$	$\%/^\circ\text{C}$
	1N823	S_Z	$\pm 0,005$	$\%/^\circ\text{C}$
	1N825	S_Z	$\pm 0,002$	$\%/^\circ\text{C}$
	1N827	S_Z	$\pm 0,001$	$\%/^\circ\text{C}$
	1N829	S_Z	$\pm 0,0005$	$\%/^\circ\text{C}$

Differential resistance at $I_Z = 7,5\text{ mA}$

$r_{diff} <$	15	Ω
--------------	----	----------

1) For accuracy of I_Z see graphs on pages 4 and 5.

Note 1 I_Z tolerance and stability of I_Z .

The quoted values of ΔV_{ref} are based on a constant current I_Z . Two factors can cause V_{ref} to change, namely the differential resistance r_{diff} and the temperature coefficient S_Z .

- a As the max. r_{diff} of the device can be 15Ω , a change of $0,01 \text{ mA}$ in the current through the reference diode will result in a ΔV_{ref} of $0,01 \text{ mA} \times 15 \Omega = 0,15 \text{ mV}$. This level of ΔV_{ref} is not significant on a 1N821 ($\Delta V_{ref} < 96 \text{ mV}$), it is however very significant on a 1N829 ($\Delta V_{ref} < 5 \text{ mV}$).
- b The temperature coefficient of the reference voltage S_Z is a function of I_Z . Reference diodes are classified at the specified test current and the S_Z of the reference diode will be different at different levels of I_Z . The absolute value of I_Z is important, however, the stability of I_Z , once the level has been set, is far more significant. This applies particularly to the 1N829.
 The effect of I_Z stability on S_Z is shown in the graph on page 5.

Note 2 Voltage excursion (ΔV_{ref} and temperature coefficient).

All reference diodes are characterized by the 'box method'. This guarantees a maximum voltage excursion (ΔV_{ref}) over the specified temperature range, at the specified test current (I_Z), verified by tests at indicated temperature points within the range. V_Z is measured and recorded at each temperature specified. The ΔV_{ref} between the highest and lowest values must not exceed the maximum ΔV_{ref} given. The temperature coefficient, therefore is given only as a reference; but may be derived from:

$$S_Z = \frac{(V_{ref 1} - V_{ref 2}) \times 100}{(T_{amb 2} - T_{amb 1}) \times V_{ref nom}} \text{ } \%/^{\circ}\text{C}$$

1N821 ; 1N823
 1N825; 1N827
 1N829

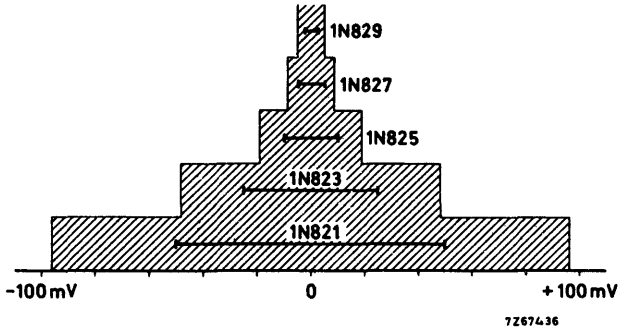

Maximum reference voltage variation (line section) caused by temperature variations within the range from -55°C to $+100^{\circ}\text{C}$ at a constant working current of $7,5\text{ mA}$. The voltage variations may shift horizontally within the shaded area. The zero point may vary from 5890 mV to 6510 mV and differs from diode to diode.

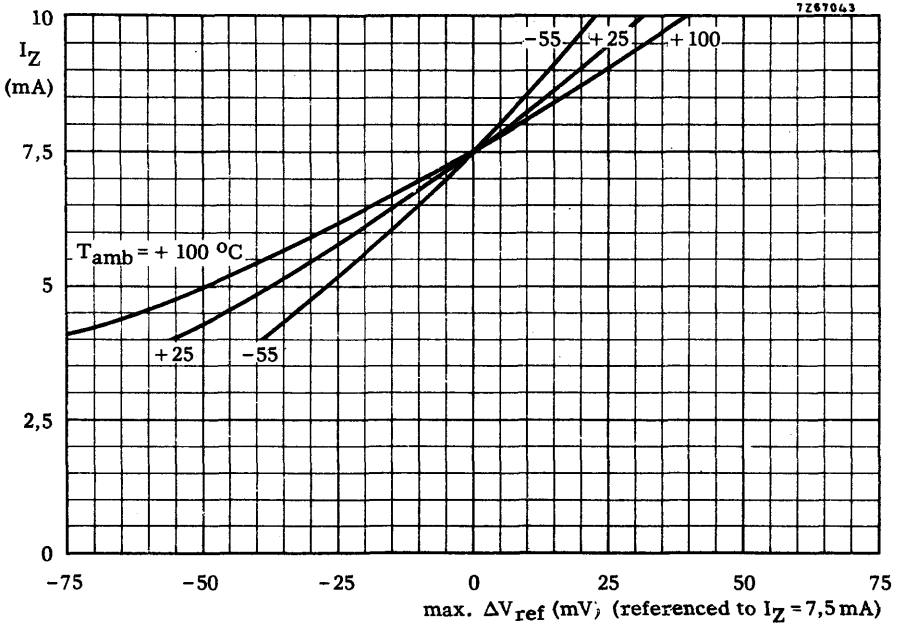

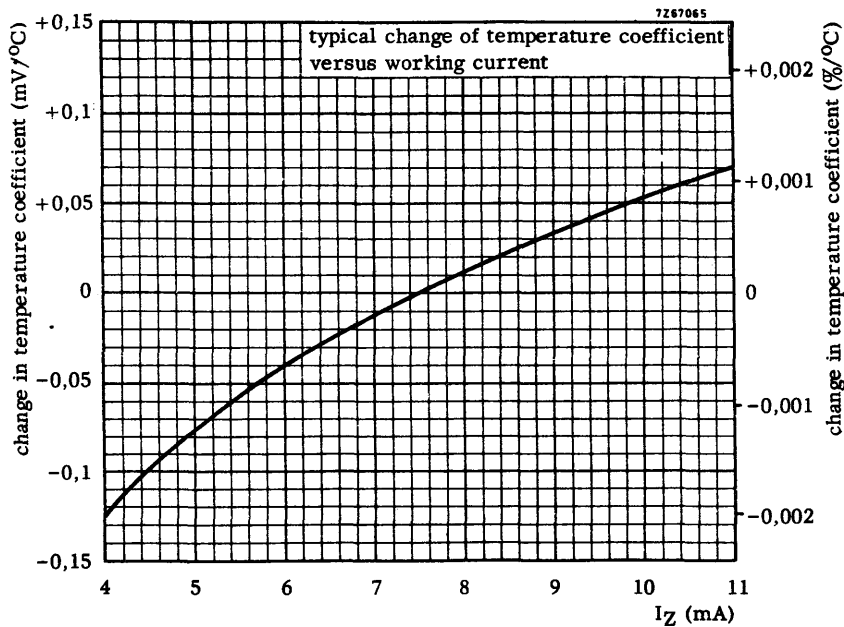
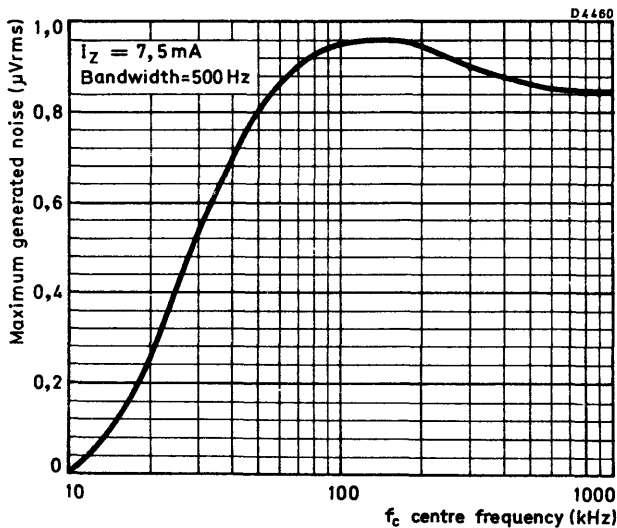

1N821; 1N823
1N825; 1N827
1N829

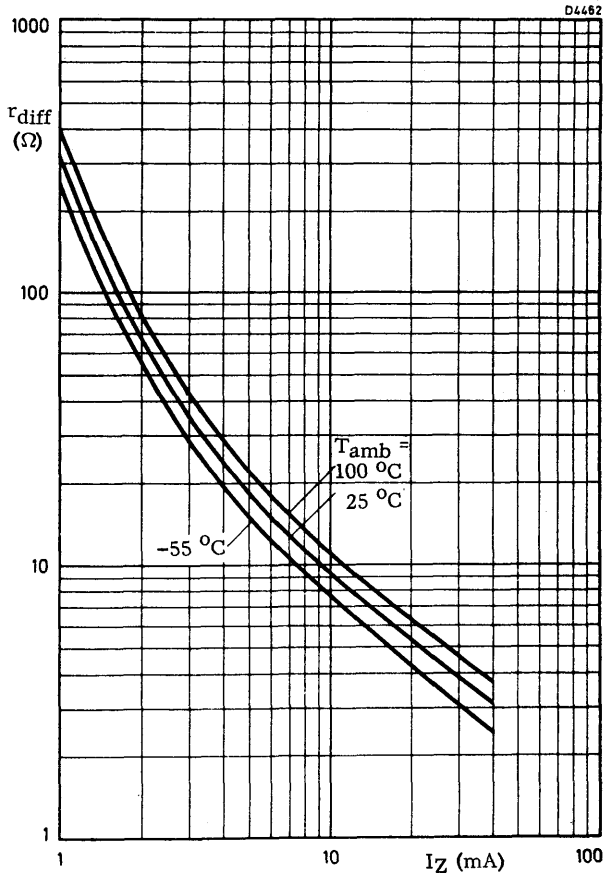

RECTIFIER DIODES

(Low power)





SILICON HIGH-VOLTAGE DIODE

Diode in a plastic envelope. It is intended for use as V_{g2} supply in colour television receivers.

QUICK REFERENCE DATA

Crest working reverse voltage	V_{RWM}	max	1500 V
Repetitive peak reverse voltage	V_{RRM}	max	1800 V
Average forward current	$I_{F(AV)}$	max	5,0 mA ←
Repetitive peak forward current	I_{FRM}	max	400 mA
Operating junction temperature	T_j	max	85 °C
Reverse recovery charge	Q_s	typ	1 nC

MECHANICAL DATA

Dimensions in mm

SOD-34 (long leads)

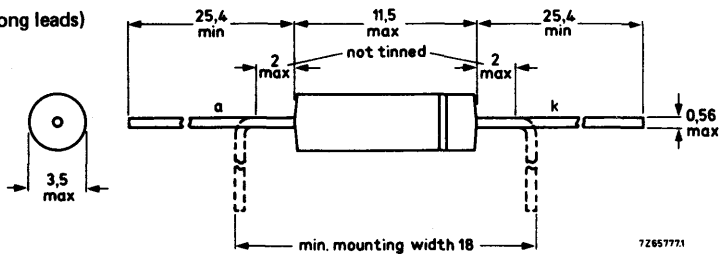

The sealing of the plastic envelope withstands the accelerated damp heat test of IEC recommendation 68-2 (test D, severity IV, 6 cycles).

Cathode indicated by coloured band. The diodes are type-branded



RATINGS Limiting values in accordance with the Absolute Maximum System (IEC 134)

Voltages

Crest working reverse voltage	V_{RWM}	max	1500 V
Repetitive peak reverse voltage	V_{RRM}	max	1800 V
Non-repetitive peak reverse voltage ($t \leq 10$ ms)	V_{RSM}	max	1800 V

Currents

→ Average forward current (averaged over any 20 ms period)	$I_{F(AV)}$	max	5,0 mA
Repetitive peak forward current	I_{FRM}	max	400 mA
Non-repetitive peak forward current ($t \leq 10$ ms)	I_{FSM}	max	5 A

Temperatures

Storage temperature	T_{stg}	-65 to +100 °C
Operating junction temperature	T_j	max 85 °C

THERMAL RESISTANCE

From junction to ambient in free air	R_{thj-a}	=	175 °C/W
--------------------------------------	-------------	---	----------

CHARACTERISTICS

Forward voltage at $I_F = 100$ mA; $T_j = 75$ °C	V_F	<	5 V
Reverse current at $V_R = 1500$ V; $T_j = 75$ °C	I_R	<	10 μ A
Reverse recovery charge when switched from $I_F = 10$ mA to $V_R = 2$ V with $\frac{dI_F}{dt} = 5$ mA/ μ s; $T_j = 25$ °C	Q_s	typ	1 nC

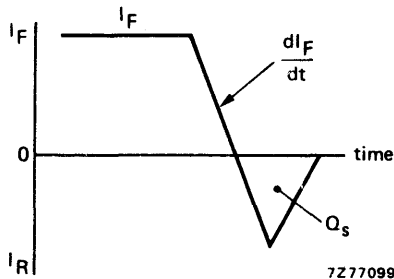

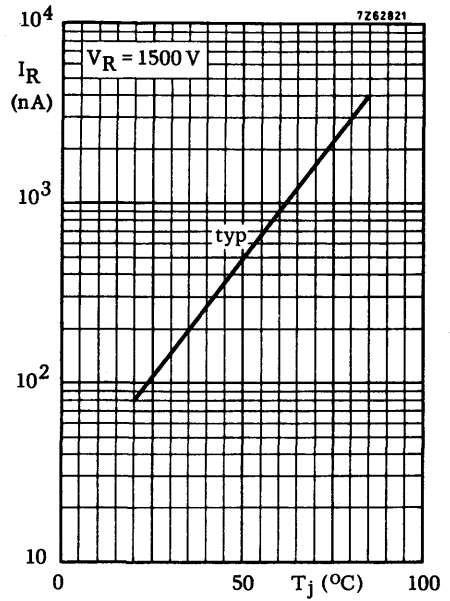
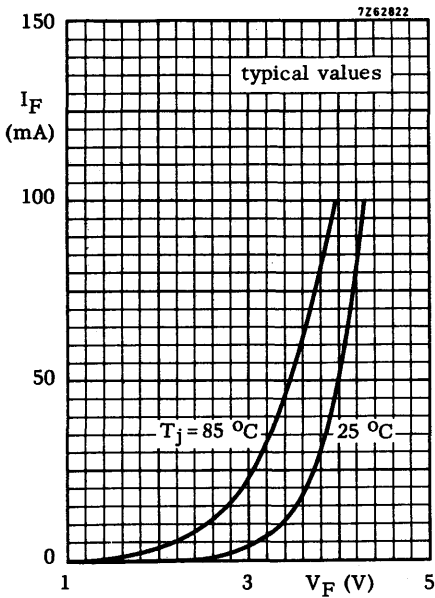
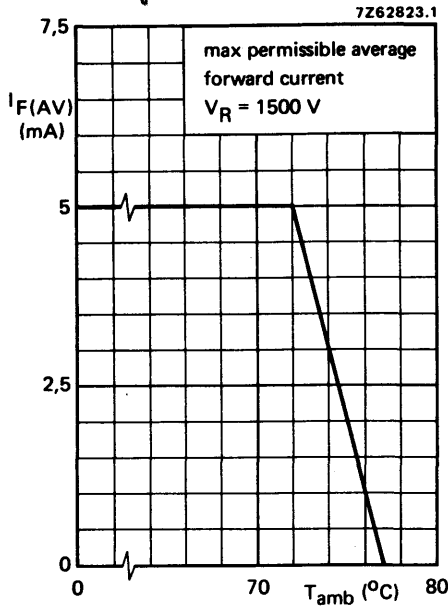

APPLICATION INFORMATION

Basic circuit for V_{g2} supply in colour television receivers

Stable continuous operation is ensured at an ambient temperature up to 70 °C.

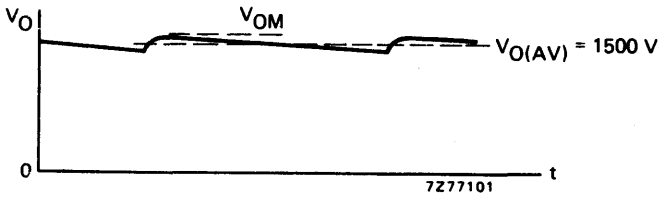
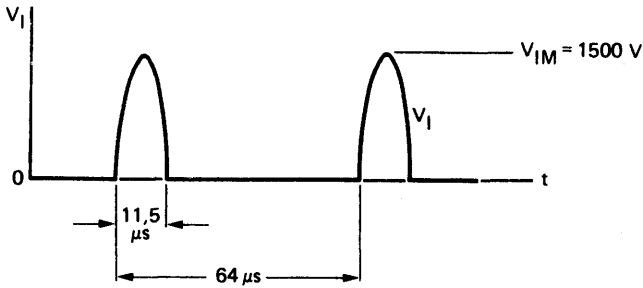
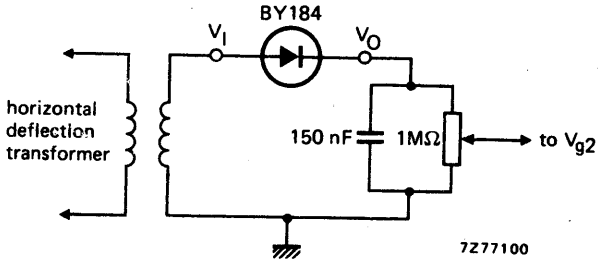

FAST SOFT-RECOVERY RECTIFIER DIODES

BY206 BY207

Silicon double-diffused rectifier diodes in plastic envelopes.
They are intended for use as top level detector, scan rectifier for the supply of small-signal parts in television and other h.f. power supplies. The devices feature non-snap-off characteristics.

QUICK REFERENCE DATA					
		BY206		BY207	
Repetitive peak reverse voltage	V_{RRM}	max.	350	600	V
Average forward current	$I_F(AV)$	max.	0,5	0,5	A
Non-repetitive peak forward current	I_{FSM}	max.	15	15	A
Reverse recovery time	t_{rr}	<	300	300	ns

MECHANICAL DATA

Dimensions in mm

Conforms to B.S. 3934 SO-8 J.E.D.E.C. DO-14

The diodes are type branded

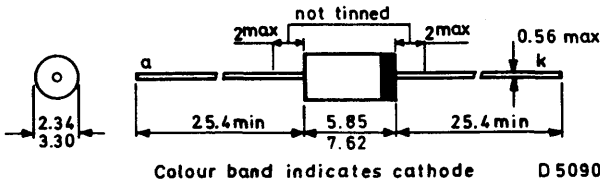

The sealing of these plastic envelopes withstands the accelerated damp heat test of I.E.C. recommendation 68-2 (test D, severity IV, 6 cycles)

Available for current production only; for new designs successors BYV95 or BAS11 are recommended.

Mullard

RATINGS Limiting values in accordance with the Absolute Maximum System (IEC 134)

Voltages

			BY206	BY207	
Non-repetitive peak reverse voltage ($t \leq 10$ ms)	V_{RSM}	max.	350	600	V
Repetitive peak reverse voltage ($t \leq 12$ μ s)	V_{RRM}	max.	350	600	V
Working reverse voltage	V_{RW}	max.	300	500	V
Continuous reverse voltage	V_R	max.	300	500	V

Currents

Average forward current (averaged over any 20 ms period; see also pages 4, 5, 8)

$$V_{RW} = V_{RWmax}$$

$$V_{RW} \leq 80 \text{ V}$$

$I_{F(AV)}$	max.	0,4	A
$I_{F(AV)}$	max.	0,5	A

Repetitive peak forward current

I_{FRM}	max.	3,0	A
-----------	------	-----	---

Repetitive peak forward current ($\delta \leq 0,03$; $f \geq 15$ kHz)

I_{FRM}	max.	5,0	A
-----------	------	-----	---

Non-repetitive peak forward current ($t = 10$ ms; half sine-wave)

$T_j = 150$ °C prior to surge

I_{FSM}	max.	15	A
-----------	------	----	---

Temperatures

Storage temperature

T_{stg}		-65 to +125	°C
-----------	--	-------------	----

Operating junction temperature

T_j	max.	150	°C
-------	------	-----	----

THERMAL RESISTANCE

See page 3

CHARACTERISTICS

Forward voltage

$$I_F = 2 \text{ A}; T_j = 25 \text{ °C}$$

V_F	<	1,55	V ¹⁾
-------	---	------	-----------------

Reverse current

$$V_R = V_{RWmax}; T_j = 125 \text{ °C}$$

$$T_j = 25 \text{ °C}$$

		BY206	BY207	
I_R	<	200	125	μ A
I_R	<	2	2	μ A

Reverse recovery when switched from

$$I_F = 0,4 \text{ A to } V_R \geq 50 \text{ V with}$$

$$-di_F/dt = 0,4 \text{ A}/\mu\text{s}; T_j = 25 \text{ °C}$$

Recovery charge

Q_s	<	60	nC
-------	---	----	----

Recovery time

t_{rr}	<	1,0	μ s
----------	---	-----	---------

Fall time

t_f	>	60	ns
-------	---	----	----

1) Measured under pulse conditions to avoid excessive dissipation.

FAST SOFT-RECOVERY RECTIFIER DIODES

BY206
BY207

CHARACTERISTICS (continued)

Reverse recovery when switched from

$$I_F = 10 \text{ mA to } V_R \geq 50 \text{ V with } -dI/dt = 0,5 \text{ A}/\mu\text{s}; T_j = 25 \text{ }^\circ\text{C}$$

Recovery time

$$t_{rr} < 300 \text{ ns}$$

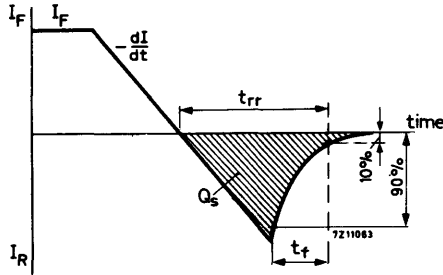

THERMAL RESISTANCE (influence of mounting method)

The quoted values of $R_{th j-a}$ should be used only when no other leads run to the tie-points. If leads of other dissipating components share the same tie-points, the thermal resistance will be higher than that quoted.

1. Mounted to solder tags at a lead-length $a = 10 \text{ mm}$

$$R_{th j-a} = 150 \text{ }^\circ\text{C/W}$$

2. Mounted to solder tags at $a = \text{maximum lead-length}$

$$R_{th j-a} = 200 \text{ }^\circ\text{C/W}$$

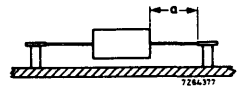

3. Mounted on printed-wiring board with a small area of copper at a lead-length $a > 5 \text{ mm}$

$$R_{th j-a} = 200 \text{ }^\circ\text{C/W}$$

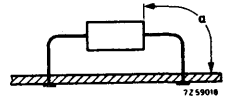

SOLDERING AND MOUNTING NOTES

1. Soldered joints must be at least 5 mm from the seal.
2. The maximum permissible temperature of the soldering bath is 300 $^\circ\text{C}$; it must not be in contact with the joint for more than 3 seconds.
3. Avoid hot spots due to handling or mounting; the body of the device must not come into contact with or be exposed to a temperature higher than 125 $^\circ\text{C}$.

Mullard

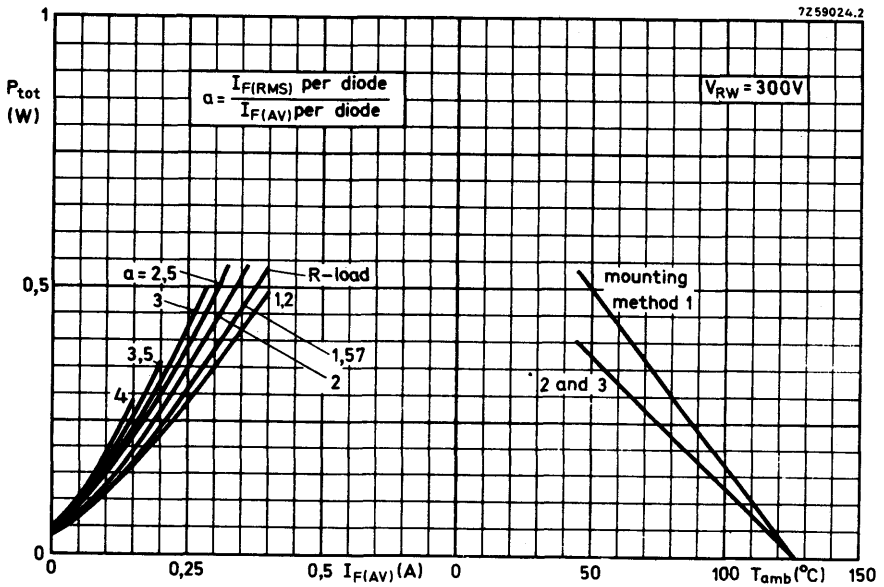
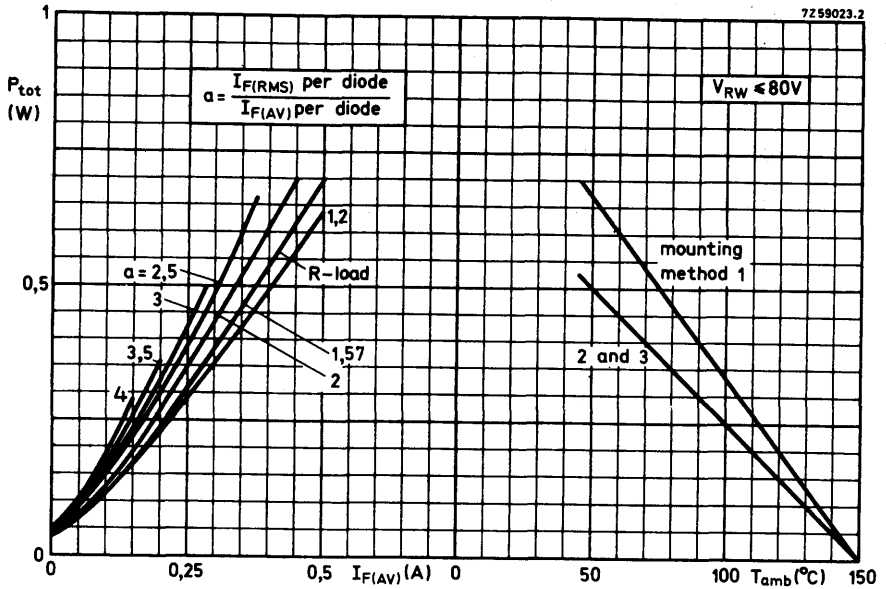

**FAST SOFT-RECOVERY
RECTIFIER DIODES**

**BY206
BY207**

7267344.1

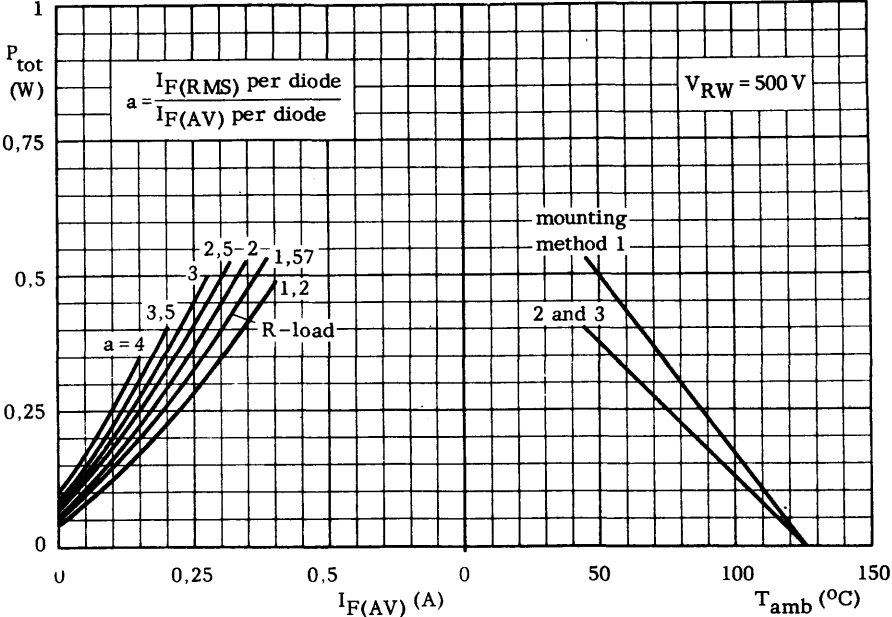

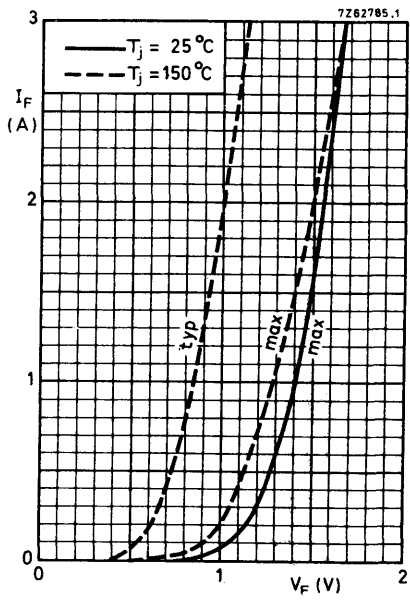
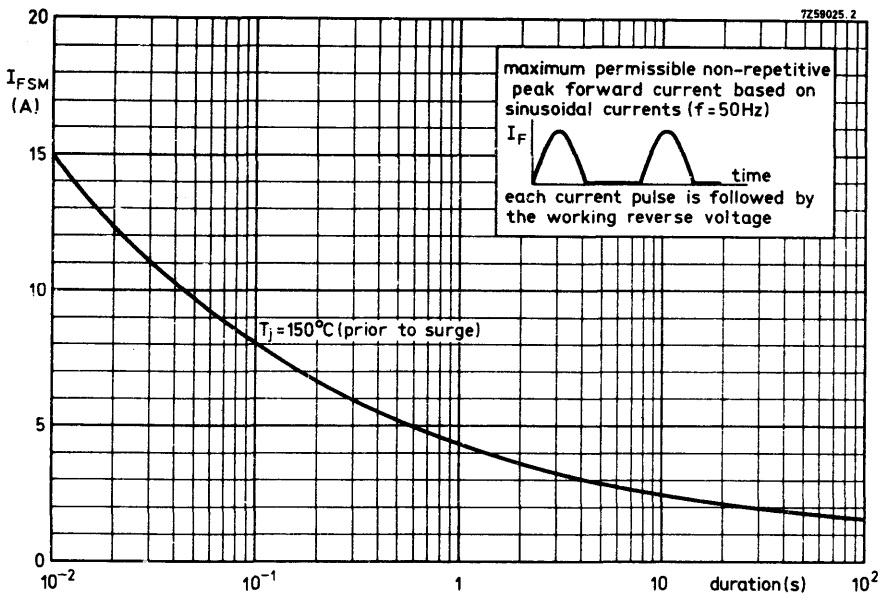

FAST SOFT-RECOVERY RECTIFIER DIODES

BY206
BY207

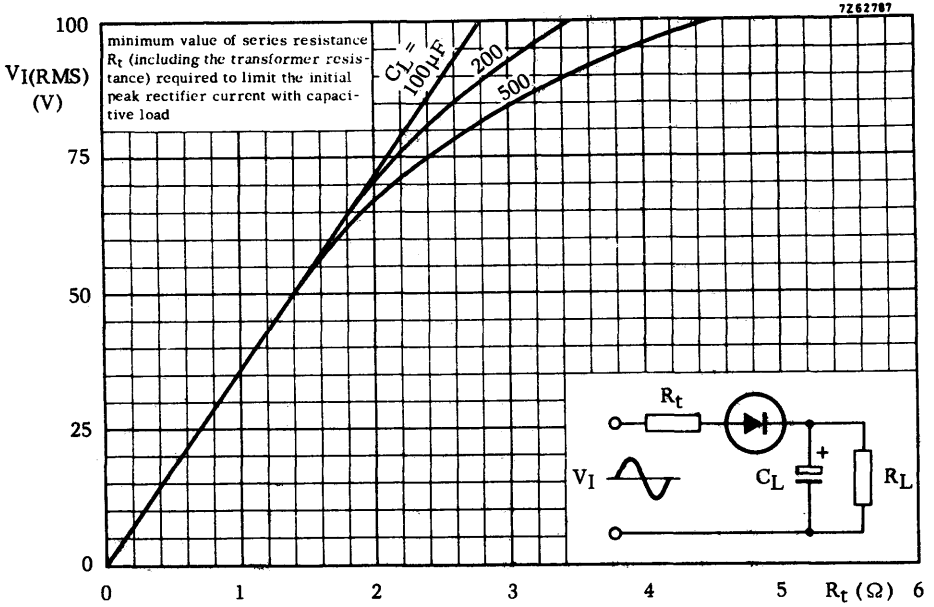

Mullard

EXAMPLE OF OPERATION WITH C LOAD

EXAMPLE OF OPERATION WITH R LOAD

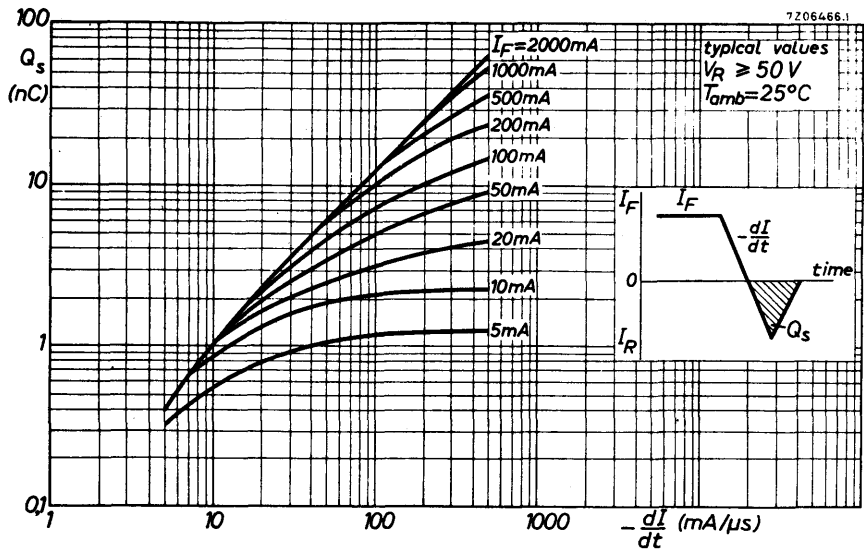
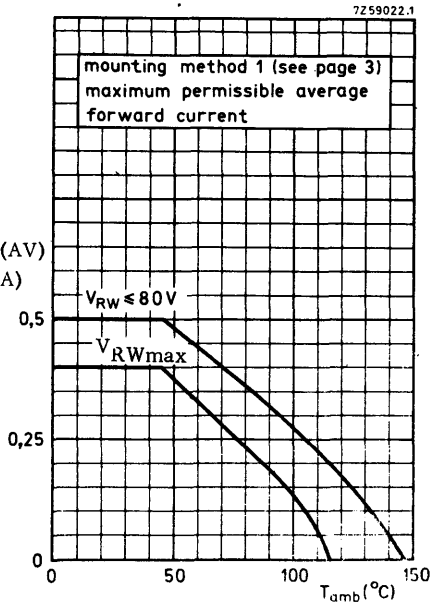
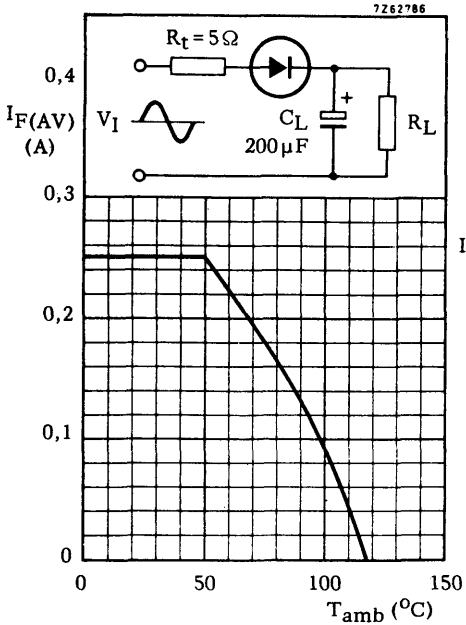

FAST SOFT-RECOVERY RECTIFIER DIODES

BY206 BY207

7206465.1

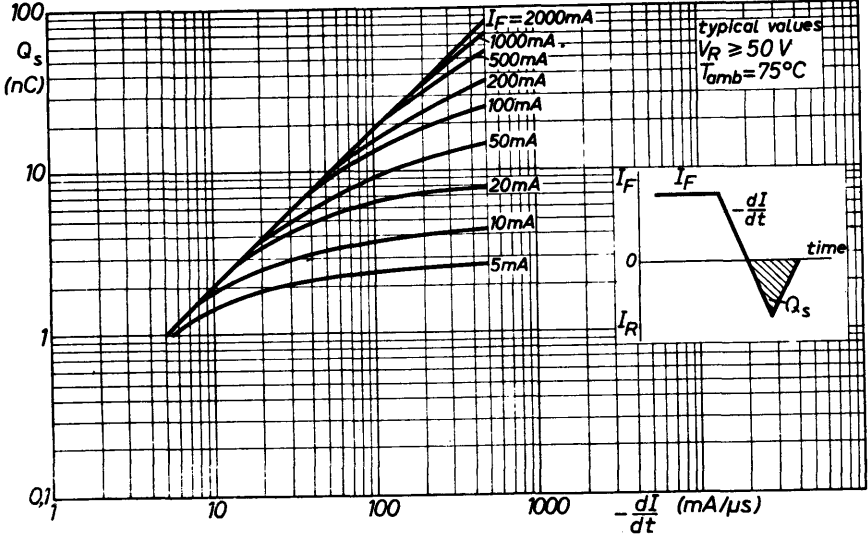

7206469.1

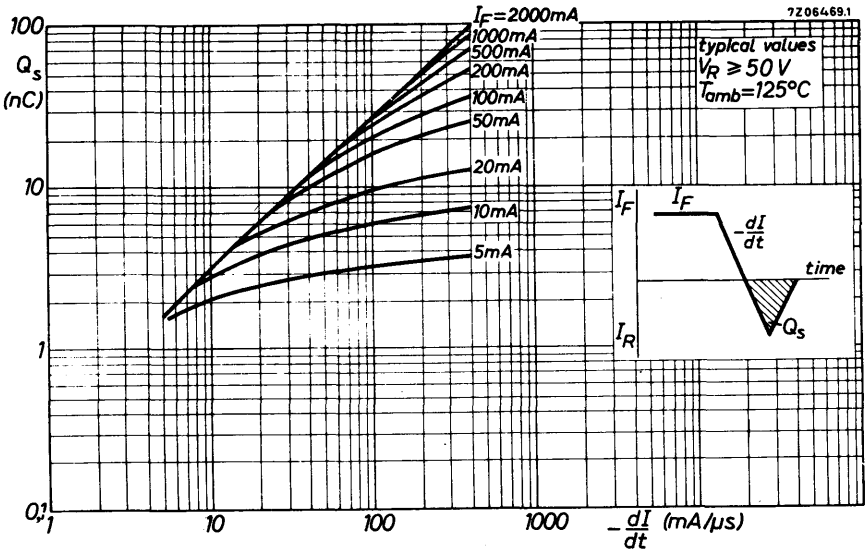

Mullard

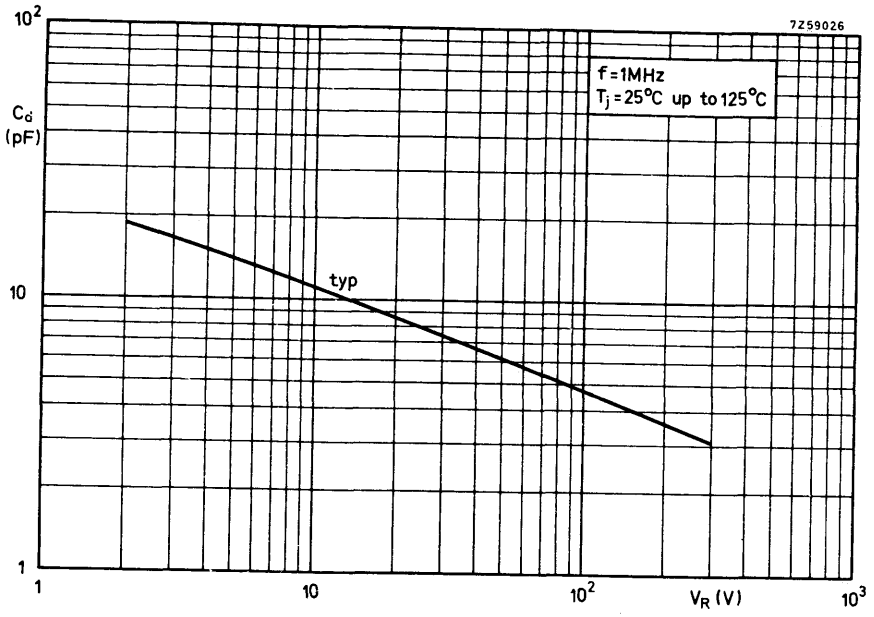

FAST SOFT-RECOVERY DIODES

A range of plastic-encapsulated fast-switching silicon rectifier diodes with "non snap-off" characteristics. The diodes are intended for use in scan rectification, switched-mode power supplies and high-speed converter applications.

QUICK REFERENCE DATA

		BY210-400 600 800			
Repetitive peak reverse voltage	V_{RRM} max.	400	600	800	V
Repetitive peak forward current	I_{FRM} max.	5.0			A
Non-repetitive peak forward current (t = 10 ms)	I_{FSM} max.	30			A
Reverse recovery time	t_{rr} <	400			ns

MECHANICAL DATA

Dimensions in mm

Fig.1 DO-15

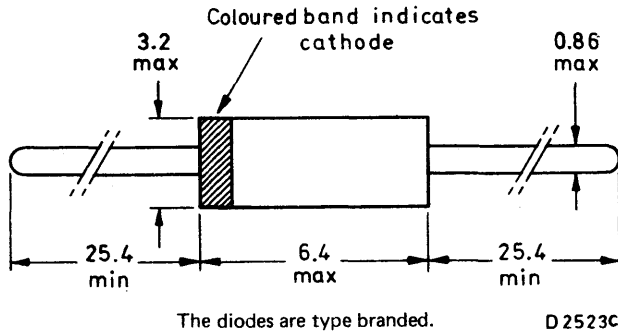

AVAILABLE FOR CURRENT PRODUCTION ONLY

FOR NEW DESIGNS THE FOLLOWING SUCCESSOR TYPES ARE RECOMMENDED:

BY210-400 = BYV95B
 BY210-600 = BYV95C
 BY210-800 = BYV96D



RATINGS

Limiting values in accordance with the Absolute Maximum System (IEC 134)

Voltages		BY210-400	600	800
Repetitive peak reverse voltage	V_{RRM} max.	400	600	800 V
Non-repetitive peak reverse voltage ($t \leq 10$ ms)	V_{RSM} max.	400	600	800 V
Currents				
Forward current (d.c.)*	I_F max.		1.0	A
Repetitive peak forward current	I_{FRM} max.		5.0	A
Non-repetitive peak forward current ($t \leq 10$ ms)	I_{FSM} max.		30	A
Temperatures				
Storage temperature	T_{stg}		-65 to +125	°C
Junction temperature	T_j max.		+125 +125 +100	°C
THERMAL RESISTANCE				
		See page 4		
CHARACTERISTICS				
Forward voltage				
$I_F = 1.0$ A, $T_j = 25$ °C	V_F	<	1.3	V
Reverse current				
$V_R = V_{RRMmax.}$, $T_j = 25$ °C	I_R	<	10	μA
$V_R = V_{RRMmax.}$, $T_j = T_j$ max.	I_R	<	200	μA
Capacitance				
$V_R = 150$ V, $T_j = +25$ to +125 °C	C_d	typ.	4.0	pF

*Provided leads are maintained at 25 °C 1 cm from the diode body

CHARACTERISTICS (continued)

Reverse recovery when switched from
 $I_F = 400 \text{ mA}$ to $V_R \geq 50 \text{ V}$, $T_j = 25 \text{ }^\circ\text{C}$

Recovered charge
 Recovery time
 Fall time

$-\frac{dI_F}{dt}$	=	$5\text{A}/\mu\text{s}$	$0.4\text{A}/\mu\text{s}$
Q_s	<	160	60 nC
t_{rr}	<	0.4	1.0 μs
t_f	>	100	100 ns

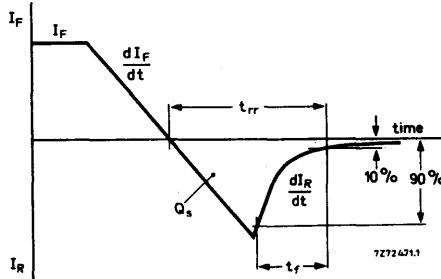

Fig.2 Definition of reverse recovery

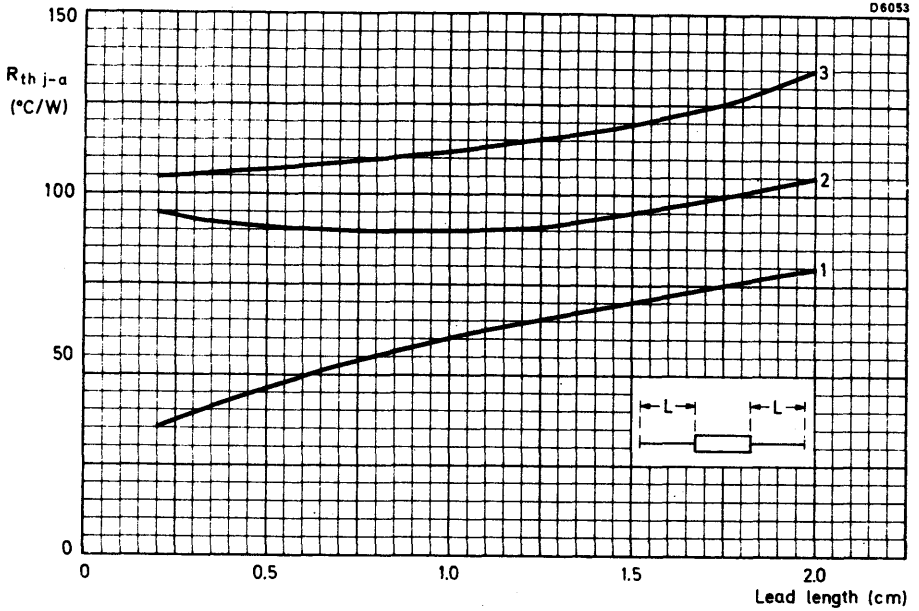

Fig.3 Thermal resistance plotted against lead length for various mountings.

Curve	Mounting
1	Infinite heatsink at end of lead
2	Typical printed circuit with large area of copper ($\geq 1.5 \text{ cm}^2$)
3	Tag mounting

N.B. The values of R_{th} apply only if no other dissipating components share the same mounting point.

OPERATING NOTES

1. Total power dissipation comprises 3 parts, namely:—

$$P_{\text{tot}} = P_{\text{F(AV)}} + P_{\text{R(AV)}} + (V_{\text{R}} \times I_{\text{R}} \times \text{duty cycle})$$

where $P_{\text{F(AV)}}$ and $P_{\text{R(AV)}}$ are derived from graphs on page 6.

$P_{\text{F(AV)}}$ is the normal forward power dissipation.

$P_{\text{R(AV)}}$ is the switching loss due to hole storage. This appears as a charge which builds up in the junction after forward current has been flowing. The combination of stored charge and reverse voltage results in reverse power loss which contributes to an increase in T_{j} .

2. Thermal resistance may be derived from:—

$$R_{\text{th}} = \frac{T_{\text{j max.}} - T_{\text{amb max.}}}{P_{\text{tot}}}$$

Once R_{th} has been determined, reference to graph on page 4 will show the practical mounting condition required.

3. Practical example

Consider a diode used as a scan rectifier:—

frequency	=	16 kHz
duty cycle	=	$\frac{52 \mu\text{s}}{64 \mu\text{s}} = 0.8$ (scan rectification)
$T_{\text{amb max.}}$	=	55 °C
Switched from		0.5 A (assume a square wave)
to		400 V
at a rate of		-5 A/ μs

therefore

$$P_{\text{F(AV)}} \text{ from graph on page 6} = 0.5 \text{ W}$$

$$P_{\text{R(AV)}} \text{ from graph on page 6} = 0.26 \text{ W}$$

therefore

$$P_{\text{tot}} = 0.76 \text{ W}$$

(Ignore $V_{\text{R}} \times I_{\text{R}} \times \text{duty cycle}$ as this is very small compared to $P_{\text{F(AV)}} + P_{\text{R(AV)}}$. In practice the worst case is, in example, $400 \times 200 \times 10^{-6} \times \frac{12}{64} = 0.015 \text{ W}$)

therefore

Maximum allowable thermal resistance is:—

$$\frac{T_{\text{j max.}} - T_{\text{amb max.}}}{P_{\text{tot}}} = \frac{125 - 55}{0.76} = 92 \text{ °C/W}$$

i.e. Curve 2 on the Mounting Conditions graph.

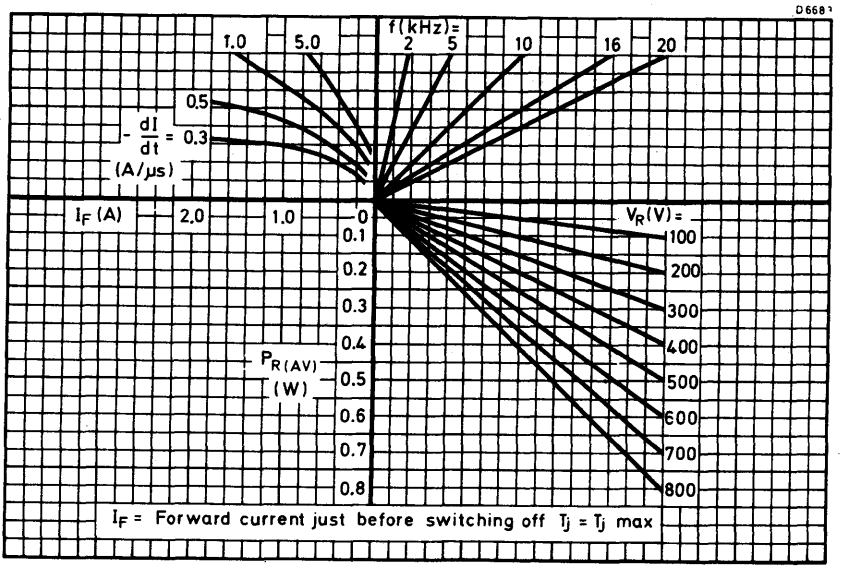
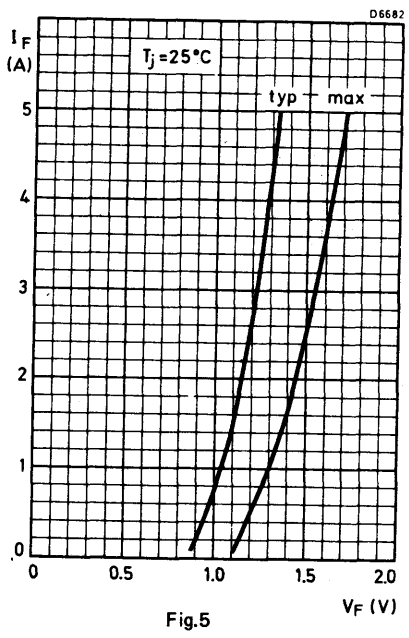
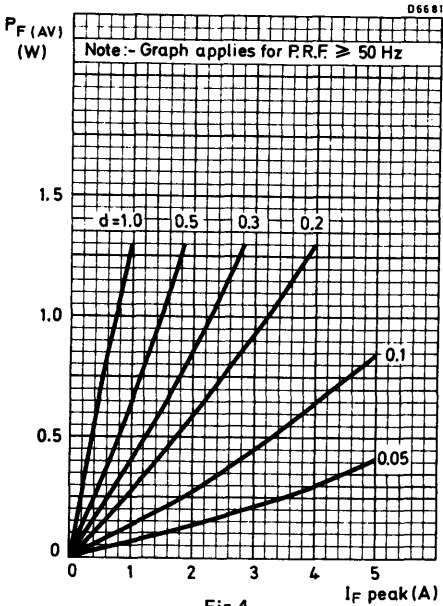

Fig.6 Nomogram: power loss $P_R(AV)$ due to switching only (to be added to forward and reverse power losses.

PARALLEL EFFICIENCY DIODE

Double-diffused passivated rectifier diode in a hermetically sealed axial-leaded glass envelope, intended for use as efficiency diode in transistorized horizontal deflection circuits of television receivers. The device features high reverse voltage capability with controlled recovery time.

QUICK REFERENCE DATA

Repetitive peak reverse voltage	V_{RRM}	max.	1500 V
Working peak forward current	I_{FWM}	max.	5 A
Repetitive peak forward current	I_{FRM}	max.	10 A
Total reverse recovery time	t_{tot}	<	20 μs

MECHANICAL DATA

Dimensions in mm

Fig. 1 SOD-64.

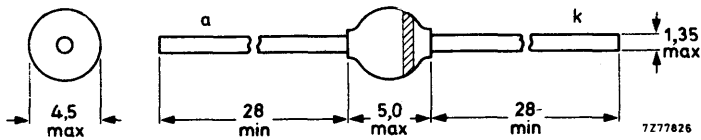

The marking band indicates the cathode.
The diodes are type-branded



RATINGS

Limiting values in accordance with the Absolute Maximum System (IEC 134)

Non-repetitive peak reverse voltage during flashover of picture tube	V_{RSM}	max.	1650 V
Repetitive peak reverse voltage	V_{RRM}	max.	1500 V
Working reverse voltage	V_{RW}	max.	1500 V
Working peak forward current	I_{FWM}	max.	5 A
Repetitive peak forward current	I_{FRM}	max.	10 A
Non-repetitive peak forward current t = 10 ms; half sine-wave; $T_j = 140\text{ }^\circ\text{C}$ prior to surge; with reapplied V_{RWmax}	I_{FSM}	max.	50 A
Storage temperature	T_{stg}		-65 to +175 $^\circ\text{C}$
Junction temperature	T_j	max.	140 $^\circ\text{C}$

THERMAL RESISTANCE

Influence of mounting method

The quoted value of $R_{th\ j-a}$ should be used only when no leads of other dissipating components run to the same tie-points.

Thermal resistance from junction to ambient when mounted on a 1,5 mm thick epoxy-glass printed-circuit board; Cu-thickness $\geq 40\ \mu\text{m}$; Fig. 2

$$R_{th\ j-a} = 75\ \text{ }^\circ\text{C/W}$$

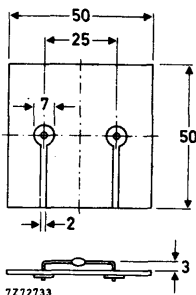

Fig. 2.

MOUNTING AND SOLDERING NOTES

Introduction

Excessive forces or temperatures applied to a diode may cause serious damage to the diode. To avoid damage when soldering and mounting, the following rules have to be followed.

Bending

During bending, the leads must be supported between body and bending point. Axial forces on the body during the bending process must not exceed 50 N. Perpendicular force on the body must be avoided as much as possible, however, if present, it shall not exceed 10 N. Bending the leads through 90° is allowed at any distance from the studs when it is possible to support the leads during the bending without contacting envelope or solder joints.

Twisting

Twisting the leads is allowed at any distance from the body if the lead is properly clamped between stud and twisting point. Without clamping, twisting is allowed only at a distance > 5 mm from the studs, the torque-angle must not exceed 30°.

Soldering

The minimum distance of soldering point to stud is 2 mm, the maximum allowed solder temperature is 300 °C, and the soldering time must not be longer than 10 seconds.

Prevent fast cooling after soldering.

When the device has to be mounted with straight or short-cropped leads, the leads should be soldered individually; bent leads may be soldered simultaneously. Do not correct the position of an already soldered device by pushing, pulling or twisting the body.

CHARACTERISTICS

Forward voltage

$I_F = 5 \text{ A}; T_j = 25 \text{ }^\circ\text{C}$

$V_F < 1,5 \text{ V}^*$

Reverse current

$V_R = V_{RWmax}; T_j = 140 \text{ }^\circ\text{C}$

$I_R < 200 \text{ } \mu\text{A}$

Total reverse recovery time when switched from

$I_F = 1 \text{ A}; -dI_F/dt = 0,05 \text{ A}/\mu\text{s}; T_j = 140 \text{ }^\circ\text{C}$

$t_{tot} < 20 \text{ } \mu\text{s}$

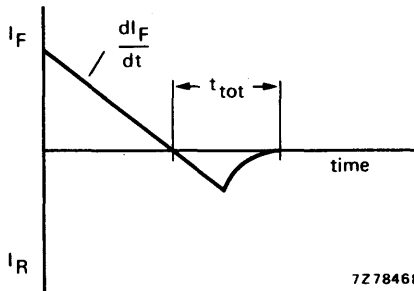

7Z78468

Fig. 3 Definition of t_{tot} .

* Measured under pulse conditions to avoid excessive dissipation.

CHARACTERISTICS (continued)

Forward recovery time when switched to
 $I_F = 5 \text{ A}$ with $t_r = 0,1 \mu\text{s}$; $T_j = 140 \text{ }^\circ\text{C}$

$t_{fr} < 1 \mu\text{s}$

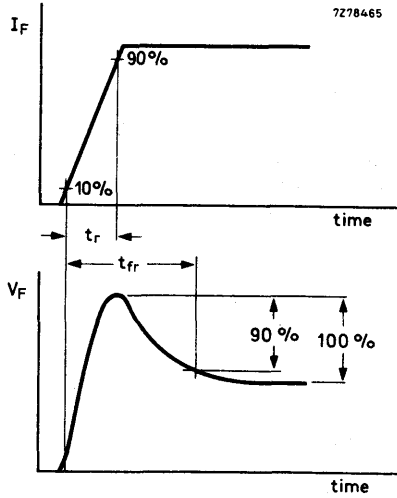

Fig. 4 Definition of t_{fr} .

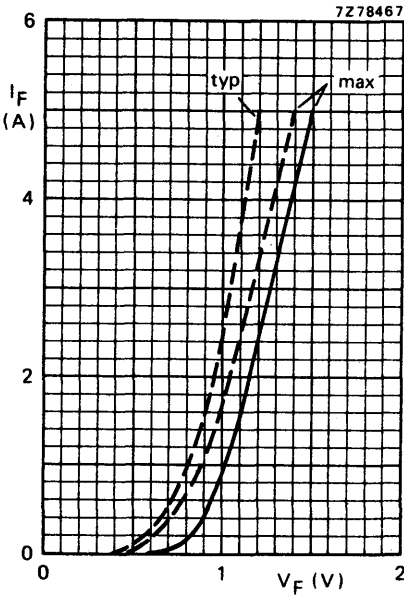

Fig. 5 — $T_j = 25 \text{ }^\circ\text{C}$; - - - $T_j = 140 \text{ }^\circ\text{C}$.

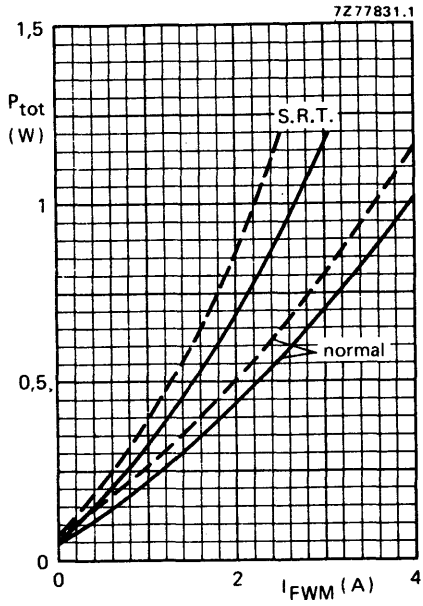

Fig. 6 P_{tot} = power dissipation including switching losses; ——— 819 lines; ——— 625 lines; S.R.T. = self regulating time-base circuit; normal = conventional deflection circuit or high-voltage E-W modulator circuit; I_{FWM} is the nominal diode current, for tolerances and spreads 25% safety margin is taken into account.

APPLICATION INFORMATION

In designing horizontal deflection circuits, allowance has to be made for component and operating spreads, in order not to exceed any Absolute Maximum Rating. Extensive analysis have shown that for the working peak current and reverse voltage the total allowance need not to be higher than 25%. For that reason the dissipation graph (Fig. 6) is based on the nominal I_{FWM} ; 25% safety margin for tolerance and spreads is taken into account.

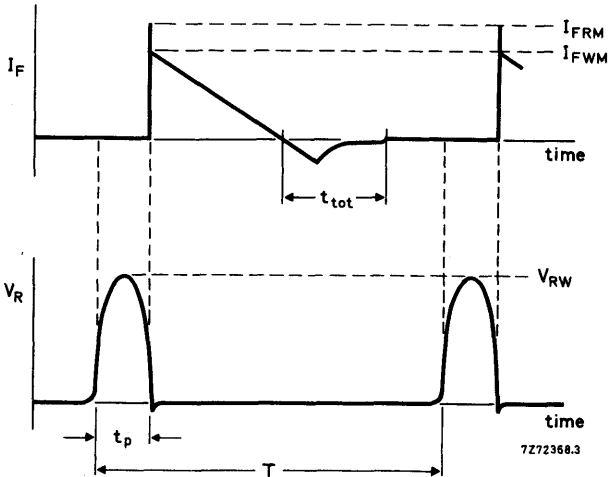

Fig. 7 Basic waveforms.

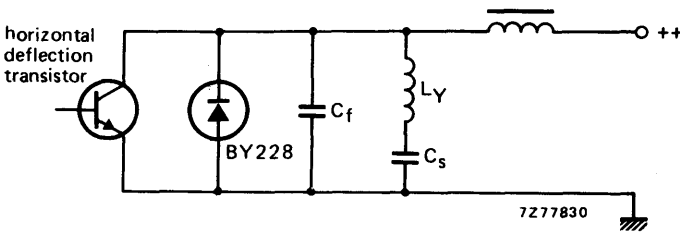

Fig. 8 Basic conventional horizontal deflection circuit.

APPLICATION INFORMATION (continued)

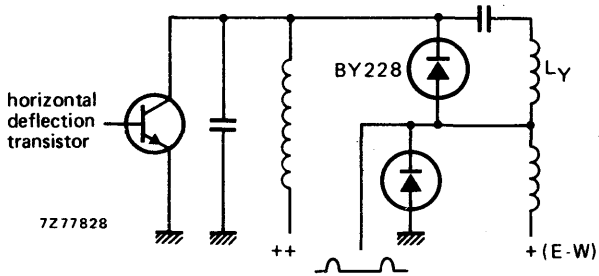

Fig. 9 Basic high-voltage E-W modulator circuit.

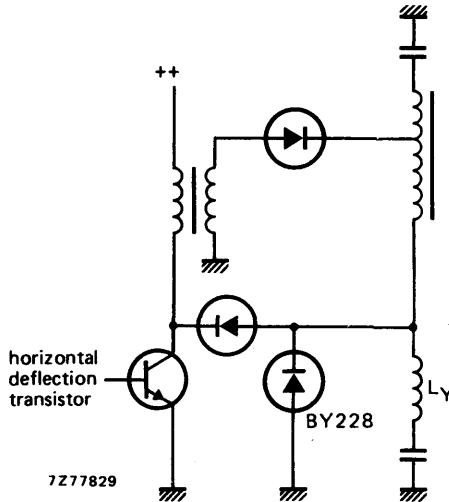
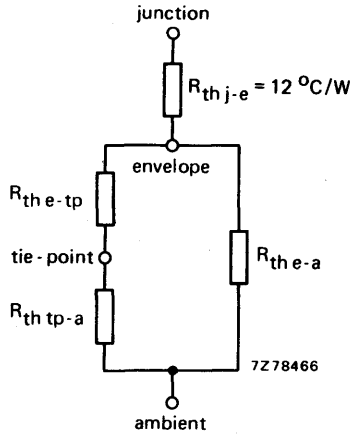

Fig. 10 Basic self-regulating time base circuit (S.R.T.).

OPERATING NOTES

The various components of junction temperature rise above ambient, for mounting with symmetrical lead length, are illustrated below.



The thermal resistances between envelope and tie-point, and between envelope and ambient depend on lead length.

lead length	5	10	15	20	25	mm
$R_{th\ e-tp}$	7,5	15	22,5	30	37,5	$^\circ\text{C/W}$
$R_{th\ e-a}$	310	230	190	160	145	$^\circ\text{C/W}$

The thermal resistance between tie-point and ambient depends on the mounting method; for mounting on a 1,5 mm thick epoxy-glass printed-circuit board with a copper-thickness $\geq 40\ \mu\text{m}$, the following values apply:

1. Mounting similar to method given on page 2: $R_{th\ tp-a} = 72\ ^\circ\text{C/W}$.
2. Mounted on a printed-circuit board with a copper laminate of $1\ \text{cm}^2$: $R_{th\ tp-a} = 58\ ^\circ\text{C/W}$.

Note

Any temperature can be calculated by using the dissipation graph (Fig. 6) and the above thermal model.

SILICON E.H.T. SOFT-RECOVERY RECTIFIER DIODES

E.H.T. rectifier diodes in plastic envelopes intended for high-voltage multipliers (e.g. tripler circuits) and as focus rectifiers in colour television receivers. The device features non-snap-off characteristics. Because of the smallness of the envelope, the diodes should be potted when used at voltages above 6 kV, see page 3.

QUICK REFERENCE DATA

Working reverse voltage	V_{RW}	max	11,5 kV
Repetitive peak reverse voltage	V_{RRM}	max	12,5 kV
Average forward current	$I_{F(AV)}$	max	2,5 mA
Junction temperature	T_j	max	100 °C
Reverse recovery			
Recovery charge	Q_s	typ	2,5 nC
Recovery time	t_{rr}	typ	0,4 μ s

MECHANICAL DATA

Dimensions in mm

SOD-34

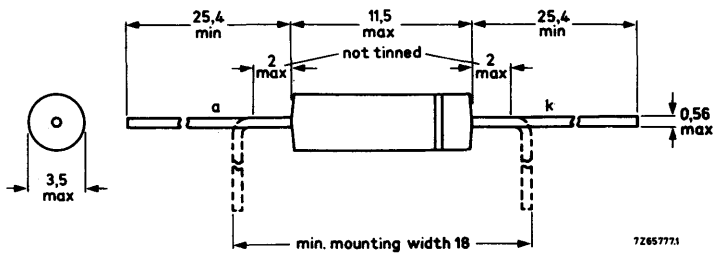

RATINGS

Limiting values in accordance with the Absolute Maximum System (IEC 134)

Voltages

Working reverse voltage	V_{RW}	max	11,5 kV
Repetitive peak reverse voltage	V_{RRM}	max	12,5 kV
Non-repetitive peak reverse voltage ($t \leq 10$ ms)	V_{RSM}	max	12,5 kV

Currents

Average forward current (averaged over any 20 ms period)	$I_{F(AV)}$	max	2,5 mA *
Repetitive peak forward current	I_{FRM}	max	500 mA **

Temperatures

Storage temperature	T_{stg}	-65 to +100 °C
Junction temperature	T_j	max 100 °C

CHARACTERISTICS

Forward voltage at $I_F = 100$ mA; $T_j = 100$ °C	V_F	<	36 V
Reverse current at $V_R = 10$ kV; $T_j = 100$ °C	I_R	<	5 μ A

Reverse recovery when switched from

$I_F = 200$ mA to $V_R = 100$ V with
 $-dI_F/dt = 200$ mA/ μ s; $T_j = 25$ °C

Recovery charge	Q_s	typ	2,5 nC
Recovery time	t_{rr}	typ	0,4 μ s
Fall time	t_f	>	0,15 μ s

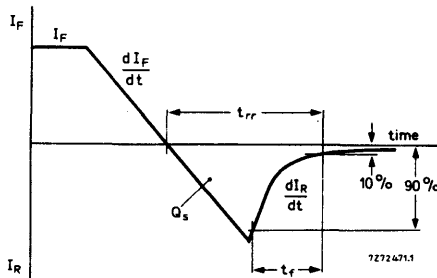

* For use as clamping diode in tripler circuits the maximum value for $I_{F(AV)} = 4$ mA up to $T_{amb} = 77$ °C.

** The rectifier can withstand peak currents occurring at flashover in the picture tube.

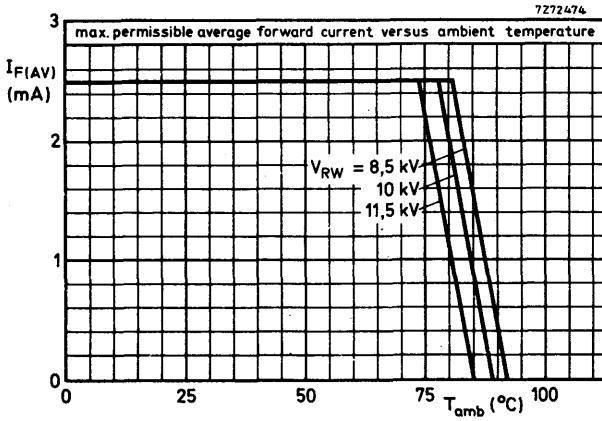

When used at voltages above 6 kV the diode should be potted in such a way that $R_{th j-a}$ is less than 120°C/W .

Typical operating circuit

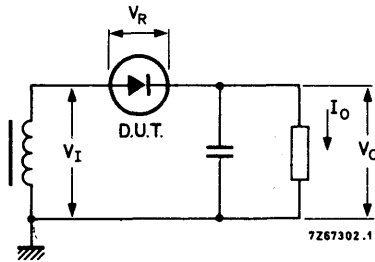

Typical applied voltage

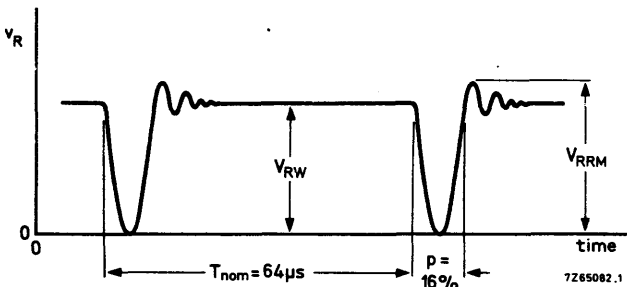

7272473

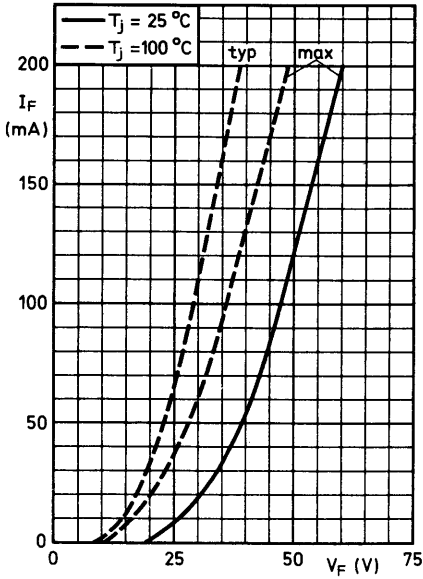

7272472

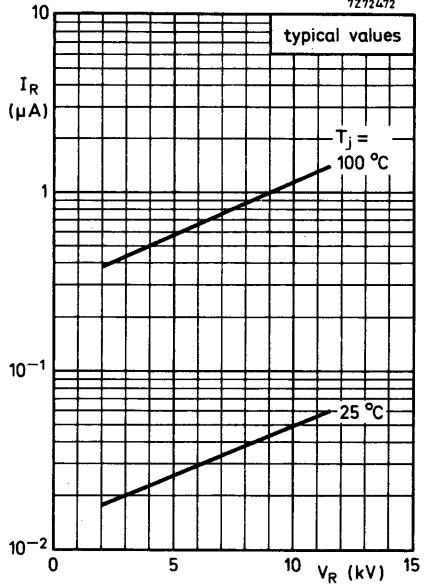

PARALLEL EFFICIENCY DIODE

Double-diffused passivated rectifier diode in a hermetically sealed axial-leaded glass envelope, intended for use as efficiency diode in transistorized horizontal deflection circuits of television receivers. The device features high reverse voltage capability with controlled recovery time.

QUICK REFERENCE DATA

Repetitive peak reverse voltage	V_{RRM}	max.	1200 V
Working peak forward current	I_{FWM}	max.	5 A
Repetitive peak forward current	I_{FRM}	max.	10 A
Total reverse recovery time	t_{tot}	<	20 μ s

MECHANICAL DATA

Dimensions in mm

Fig. 1 SOD-64.

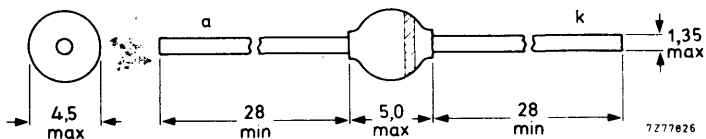

The marking band indicates the cathode.
The diodes are type-branded

RATINGS

Limiting values in accordance with the Absolute Maximum System (IEC 134)

Non-repetitive peak reverse voltage during flashover of picture tube	V_{RSM}	max.	1300 V
Repetitive peak reverse voltage	V_{RRM}	max.	1200 V
Working peak forward current	I_{FWM}	max.	5 A
Repetitive peak forward current	I_{FRM}	max.	10 A
Non-repetitive peak forward current $t = 10$ ms; half sine-wave; $T_j = 140$ °C prior to surge; with reapplied V_{RWmax}	I_{FSM}	max.	50 A
Storage temperature	T_{stg}		-65 to +175 °C
Junction temperature	T_j	max.	140 °C

THERMAL RESISTANCE

Influence of mounting method

The quoted value of $R_{th\ j-a}$ should be used only when no leads of other dissipating components run to the same tie-points.

Thermal resistance from junction to ambient when mounted on a 1,5 mm thick epoxy-glass printed-circuit board; Cu-thickness ≥ 40 μ m; Fig. 2

$$R_{th\ j-a} = 75 \text{ } ^\circ\text{C/W}$$

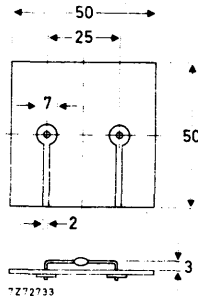

Fig. 2.

MOUNTING AND SOLDERING NOTES

Introduction

Excessive forces or temperatures applied to a diode may cause serious damage to the diode. To avoid damage when soldering and mounting, the following rules have to be followed.

Bending

During bending, the leads must be supported between body and bending point. Axial forces on the body during the bending process must not exceed 50 N. Perpendicular force on the body must be avoided as much as possible, however, if present, it shall not exceed 10 N. Bending the leads through 90° is allowed at any distance from the studs when it is possible to support the leads during the bending without contacting envelope or solder joints.

Twisting

Twisting the leads is allowed at any distance from the body if the lead is properly clamped between stud and twisting point. Without clamping, twisting is allowed only at a distance > 5 mm from the studs, the torque-angle must not exceed 30°.

Soldering

The minimum distance of soldering point to stud is 2 mm, the maximum allowed solder temperature is 300 °C, and the soldering time must not be longer than 10 seconds.

Prevent fast cooling after soldering.

When the device has to be mounted with straight or short-cropped leads, the leads should be soldered individually; bent leads may be soldered simultaneously. Do not correct the position of an already soldered device by pushing, pulling or twisting the body.

CHARACTERISTICS

Forward voltage $I_F = 5 \text{ A}; T_j = 25 \text{ }^\circ\text{C}$	V_F	<	1,5 V*
Reverse current $V_R = V_{RW_{max}}; T_j = 140 \text{ }^\circ\text{C}$	I_R	<	200 μA
Total reverse recovery time when switched from $I_F = 1 \text{ A}; -di_F/dt = 0,05 \text{ A}/\mu\text{s}; T_j = 140 \text{ }^\circ\text{C}$	t_{tot}	<	20 μs

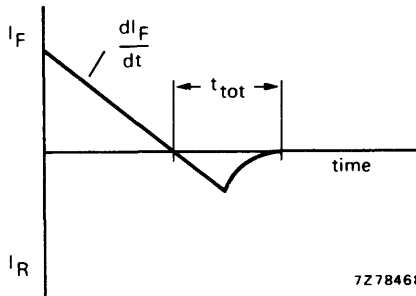

Fig. 3 Definition of t_{tot} .

* Measured under pulse conditions to avoid excessive dissipation.

CHARACTERISTICS (continued)

Forward recovery time when switched to $I_F = 5 \text{ A}$ with $t_r = 0,1 \mu\text{s}$; $T_j = 140 \text{ }^\circ\text{C}$

$t_{fr} < 1 \mu\text{s}$

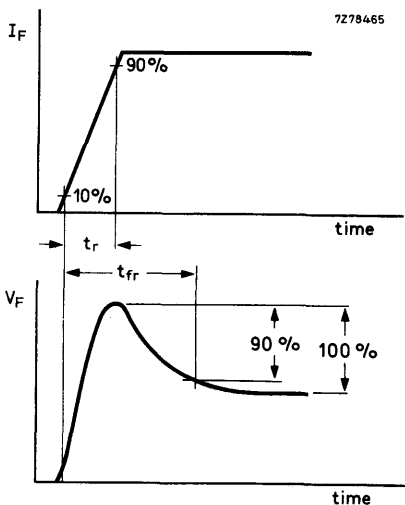

Fig. 4 Definition of t_{fr} .

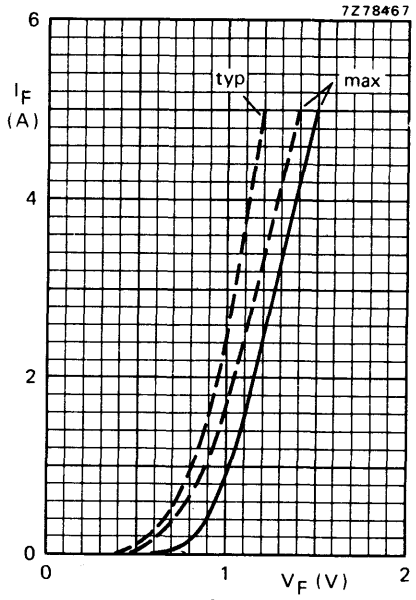

Fig. 5 — $T_j = 25 \text{ }^\circ\text{C}$; - - $T_j = 140 \text{ }^\circ\text{C}$.

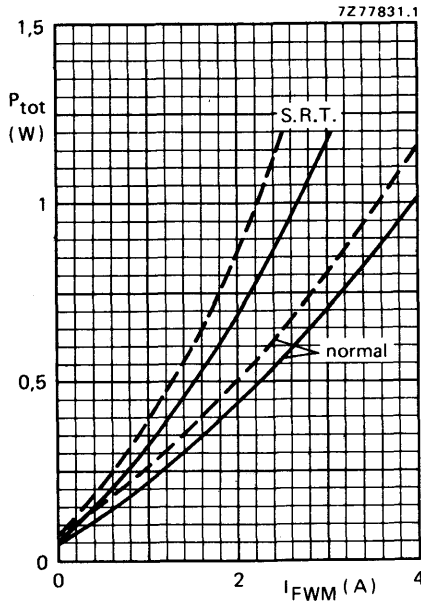

Fig. 6 P_{tot} = power dissipation including switching losses; ——— 819 lines; ——— 625 lines; S.R.T. = self regulating time-base circuit; normal = conventional deflection circuit or high-voltage E-W modulator circuit; I_{FWM} is the nominal diode current, for tolerances and spreads 25% safety margin is taken into account.

APPLICATION INFORMATION

In designing horizontal deflection circuits, allowance has to be made for component and operating spreads, in order not to exceed any Absolute Maximum Rating.

Extensive analysis have shown that for the working peak forward current and reverse voltage the total allowance need not to be higher than 25%. For that reason the dissipation graph (Fig. 6) is based on the nominal I_{FWM} ; 25% safety margin for tolerance and spreads is taken into account.

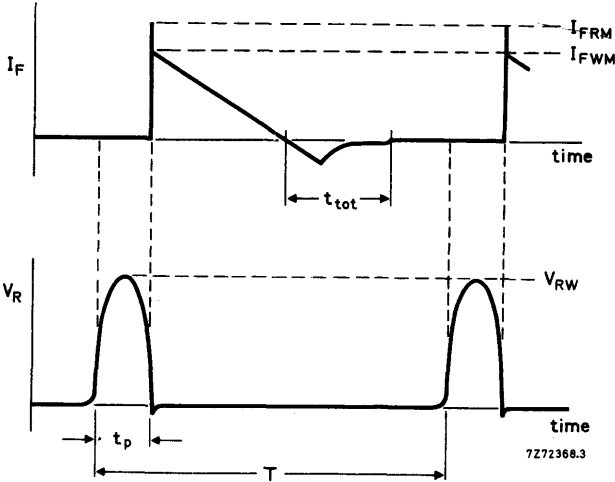

Fig. 7 Basic waveforms.

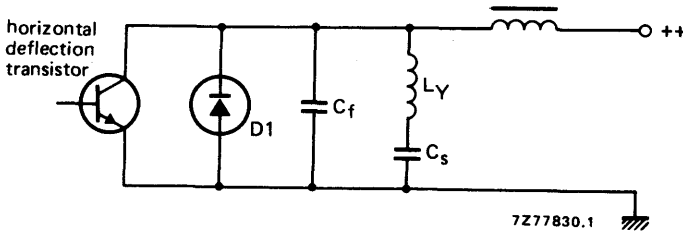

Fig. 8 Basic conventional horizontal deflection circuit.
D1 = BY438.

APPLICATION INFORMATION (continued)

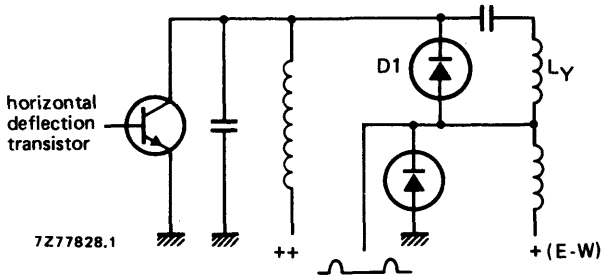

Fig. 9 Basic high-voltage E-W modulator circuit. D1 = BY438.

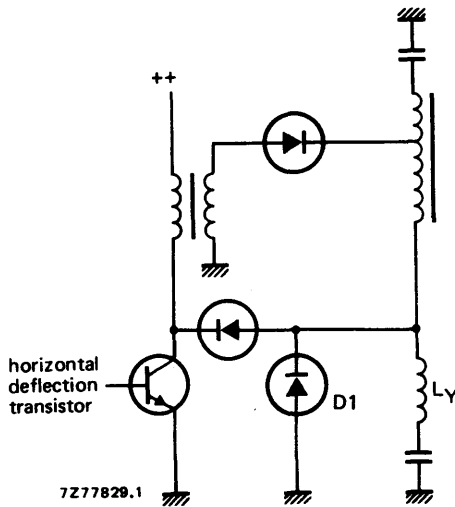
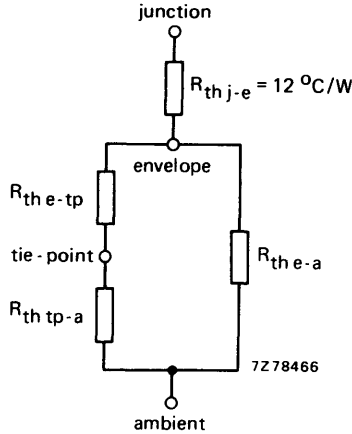

Fig. 10 Basic self-regulating time base circuit (S.R.T.). D1 = BY438.

OPERATING NOTES

The various components of junction temperature rise above ambient, for mounting with symmetrical lead length, are illustrated below.



The thermal resistances between envelope and tie-point, and between envelope and ambient depend on lead length.

lead length	5	10	15	20	25	mm
$R_{th\ e-tp}$	7,5	15	22,5	30	37,5	°C/W
$R_{th\ e-a}$	310	230	190	160	145	°C/W

The thermal resistance between tie-point and ambient depends on the mounting method; for mounting on a 1,5 mm thick epoxy-glass printed-circuit board with a copper-thickness $\geq 40\ \mu\text{m}$, the following values apply:

1. Mounting similar to method given on page 2: $R_{th\ tp-a} = 72\ \text{°C/W}$.
2. Mounted on a printed-circuit board with a copper laminate of $1\ \text{cm}^2$: $R_{th\ tp-a} = 58\ \text{°C/W}$.

Note

Any temperature can be calculated by using the dissipation graph (Fig. 6) and the above thermal model.

PARALLEL EFFICIENCY DIODES

Double-diffused passivated rectifier diodes in hermetically sealed axial-leaded glass envelopes, intended for use as efficiency diodes in transistorized horizontal deflection circuits and PPS (power-pack system) circuits of television receivers. The devices feature high reverse voltage capability with controlled recovery time.

QUICK REFERENCE DATA

		BY458	BY448
Repetitive peak reverse voltage	V_{RRM} max.	1200	1500 V
Working peak forward current	I_{FWM} max.	4	A
Repetitive peak forward current	I_{FRM} max.	8	A
Total reverse recovery time	t_{tot}	< 20	μs

MECHANICAL DATA

Dimensions in mm

Fig. 1 SOD-57.

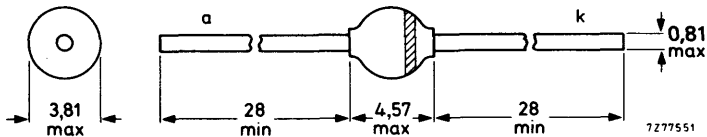

The marking band indicates the cathode.
The diodes are type-branded

RATINGS

Limiting values in accordance with the Absolute Maximum System (IEC 134)

		BY458	BY448
Non-repetitive peak reverse voltage during flashover of picture tube	V_{RSM}	max. 1300	1650 V
Repetitive peak reverse voltage	V_{RRM}	max. 1200	1500 V
Working peak forward current	I_{FWM}	max. 4	A
Repetitive peak forward current	I_{FRM}	max. 8	A
Non-repetitive peak forward current t = 10 ms; half sine-wave; $T_j = 140\text{ }^\circ\text{C}$ prior to surge; with reapplied V_{RRMmax}	I_{FSM}	max. 30	A
Storage temperature	T_{stg}	-65 to +175	$^\circ\text{C}$
Operating junction temperature	T_j	max. 140	$^\circ\text{C}$

THERMAL RESISTANCE

Influence of mounting method (see also OPERATING NOTES and Fig. 11)

The quoted value of $R_{th\ j-a}$ should be used only when no leads of other dissipating components run to the same tie-points.

Thermal resistance from junction to ambient when mounted on a 1,5 mm thick epoxy-glass printed-circuit board; Cu-thickness $\geq 40\ \mu\text{m}$; Fig. 2

$$R_{th\ j-a} = 100\ \text{ }^\circ\text{C/W}$$

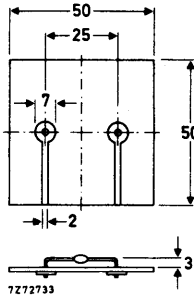

Fig. 2.

MOUNTING AND SOLDERING NOTES

Introduction

Excessive forces or temperatures applied to a diode may cause serious damage to the diode. To avoid damage when soldering and mounting, the following rules have to be followed.

Bending

During bending, the leads must be supported between body and bending point. Axial forces on the body during the bending process must not exceed 50 N. Perpendicular force on the body must be avoided as much as possible, however, if present, it shall not exceed 10 N. Bending the leads through 90° is allowed at any distance from the studs when it is possible to support the leads during the bending without contacting envelope or solder joints.

Twisting

Twisting the leads is allowed at any distance from the body if the lead is properly clamped between stud and twisting point. Without clamping, twisting is allowed only at a distance > 5 mm from the studs, the torque-angle must not exceed 30°.

Soldering

The minimum distance of soldering point to stud is 2 mm, the maximum allowed solder temperature is 300 °C, and the soldering time must not be longer than 10 seconds.

Prevent fast cooling after soldering.

When the device has to be mounted with straight or short-cropped leads, the leads should be soldered individually; bent leads may be soldered simultaneously. Do not correct the position of an already soldered device by pushing, pulling or twisting the body.

CHARACTERISTICS

Forward voltage

$I_F = 3 \text{ A}; T_j = 25 \text{ }^\circ\text{C}$

$V_F < 1,6 \text{ V}^*$

Reverse current

$V_R = V_{RRMmax}; T_j = 140 \text{ }^\circ\text{C}$

$I_R < 200 \text{ } \mu\text{A}$

Total reverse recovery time when switched from

$I_F = 1 \text{ A}; -dI_F/dt = 0,05 \text{ A}/\mu\text{s}; T_j = 140 \text{ }^\circ\text{C}$

$t_{tot} < 20 \text{ } \mu\text{s}$

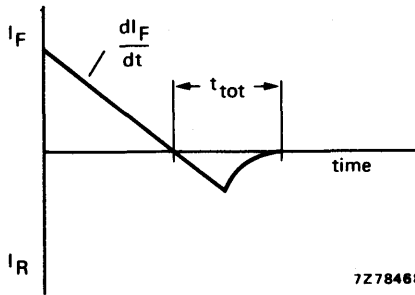

Fig. 3 Definition of t_{tot} .

* Measured under pulse conditions to avoid excessive dissipation.

CHARACTERISTICS (continued)

Forward recovery time when switched to
 $I_F = 4 \text{ A}$ with $t_r = 0,1 \mu\text{s}$; $T_j = 140 \text{ }^\circ\text{C}$

$t_{fr} < 1 \mu\text{s}$

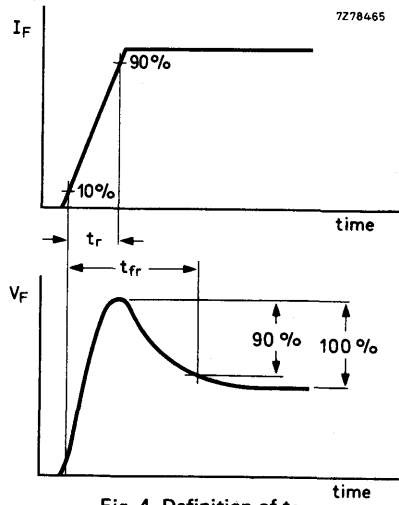

Fig. 4 Definition of t_{fr} .

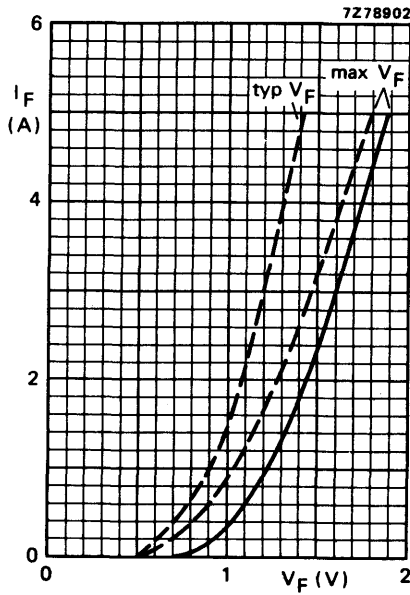

Fig. 5 — $T_j = 25 \text{ }^\circ\text{C}$; --- $T_j = 140 \text{ }^\circ\text{C}$.

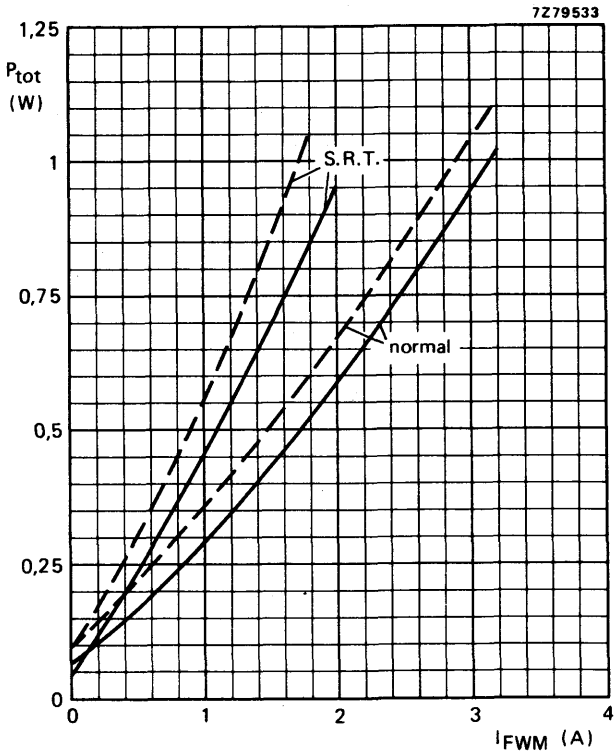

Fig. 6 P_{tot} = maximum power dissipation including switching losses; --- 819 lines; — 625 lines; S.R.T. = self regulating time-base circuit; normal = conventional deflection circuit or high-voltage E-W modulator circuit; I_{FWM} = the nominal peak diode current, for tolerances and spreads 25% safety margin is taken into account.

APPLICATION INFORMATION

In designing horizontal deflection circuits, allowance has to be made for component and operating spreads, in order not to exceed any Absolute Maximum Rating.

Extensive analysis have shown that for the working peak forward current and reverse voltage the total allowance need not to be higher than 25%. For that reason the dissipation graph (Fig. 6) is based on the nominal I_{FWM} ; 25% safety margin for tolerance and spreads is taken into account.

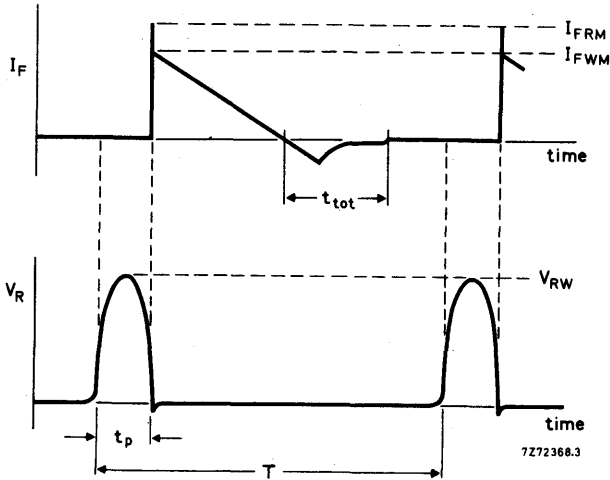

Fig. 7 Basic waveforms.

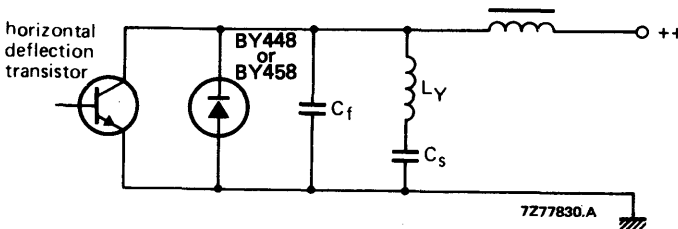

Fig. 8 Basic conventional horizontal deflection circuit.

APPLICATION INFORMATION (continued)

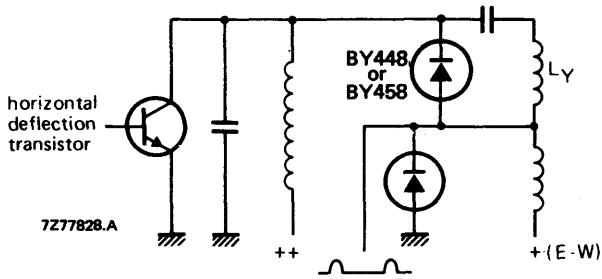

Fig. 9 Basic high-voltage E-W modulator circuit.

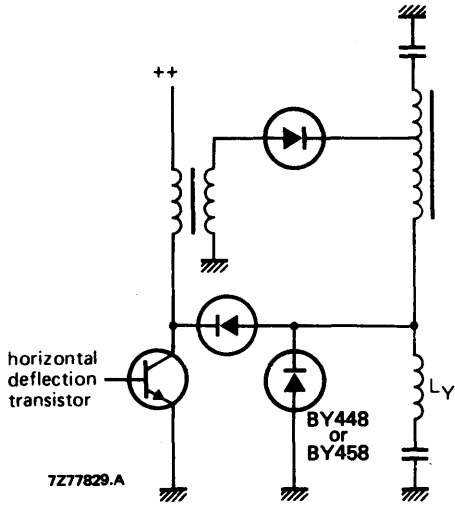

Fig. 10 Basic self-regulating time base circuit (S.R.T.).

OPERATING NOTES

The various components of junction temperature rise above ambient, for mounting with symmetrical lead length, are illustrated below.

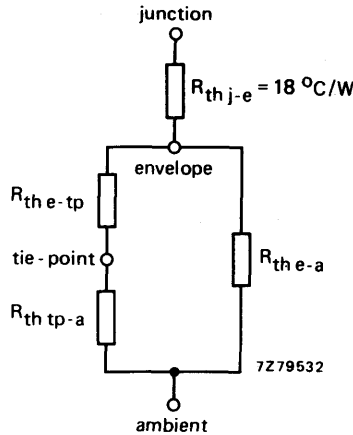

Fig. 11.

The thermal resistances between envelope and tie-point, and between envelope and ambient depend on lead length.

lead length	5	10	15	20	25	mm
$R_{th\ e-tp}$	15	30	45	60	75	$^{\circ}C/W$
$R_{th\ e-a}$	580	445	350	290	245	$^{\circ}C/W$

The thermal resistance between tie-point and ambient depends on the mounting method; for mounting on a 1,5 mm thick epoxy-glass printed-circuit board with a copper-thickness $\geq 40\ \mu m$, the following values apply:

1. Mounting similar to method given on page 2: $R_{th\ tp-a} = 70\ ^{\circ}C/W$.
2. Mounted on a printed-circuit board with a copper laminate (per lead) of:
 - 1 cm^2 $R_{th\ tp-a} = 55\ ^{\circ}C/W$.
 - 2,25 cm^2 $R_{th\ tp-a} = 45\ ^{\circ}C/W$.

Note

Any temperature can be calculated by using the dissipation graph (Fig. 6) and the above thermal model.

SILICON E.H.T. SOFT-RECOVERY RECTIFIER DIODES

E.H.T. rectifier diodes in plastic envelopes intended for high-voltage multipliers and for use in tiny vision black-and-white television receivers. Because of the smallness of the envelope, the diodes should be potted when used at voltages above 9 kV, see page 3.

QUICK REFERENCE DATA

Working reverse voltage	V_{RW}	max	16 kV
Repetitive peak reverse voltage	V_{RRM}	max	18 kV
Average forward current	$I_{F(AV)}$	max	2,5 mA
Junction temperature	T_j	max	100 °C
Reverse recovery			
Recovery charge	Q_s	typ	2,5 nC
Recovery time	t_{rr}	typ	0,4 μ s

MECHANICAL DATA

Dimensions in mm

SOD-56

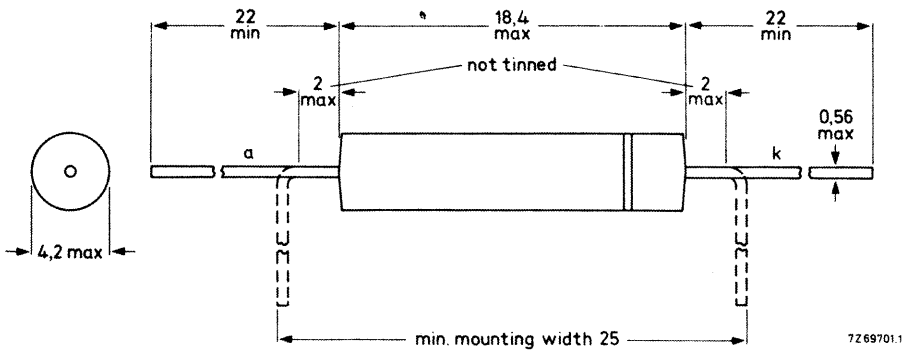

RATINGS

Limiting values in accordance with the Absolute Maximum System (IEC 134)

Voltages

Working reverse voltage	V_{RW}	max	16 kV
Repetitive peak reverse voltage	V_{RRM}	max	18 kV
Non-repetitive peak reverse voltage ($t \leq 10$ ms)	V_{RSM}	max	21 kV

Currents

Average forward current (averaged over any 20 ms period)	$I_{F(AV)}$	max	2,5 mA
Repetitive peak forward current	I_{FRM}	max	500 mA *

Temperatures

Storage temperature	T_{stg}	-65 to +100 °C
Junction temperature	T_j	max 100 °C

CHARACTERISTICS

Forward voltage at $I_F = 100$ mA; $T_j = 100$ °C $V_F < 44$ V

Reverse current at $V_R = 15$ kV; $T_j = 100$ °C $I_R < 5$ μ A

Reverse recovery when switched from

$I_F = 200$ mA to $V_R = 100$ V with
 $-dI_F/dt = 200$ mA/ μ s; $T_j = 25$ °C

Recovery charge	Q_S	typ	2,5 nC
Recovery time	t_{rr}	typ	0,4 μ s
Fall time	t_f	>	0,15 μ s

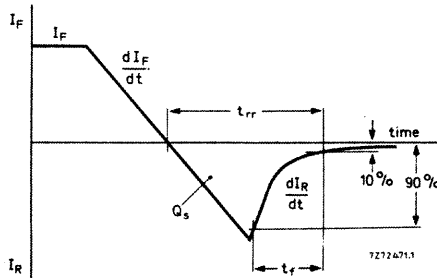

* The rectifier can withstand peak currents occurring at flashover in the picture tube.

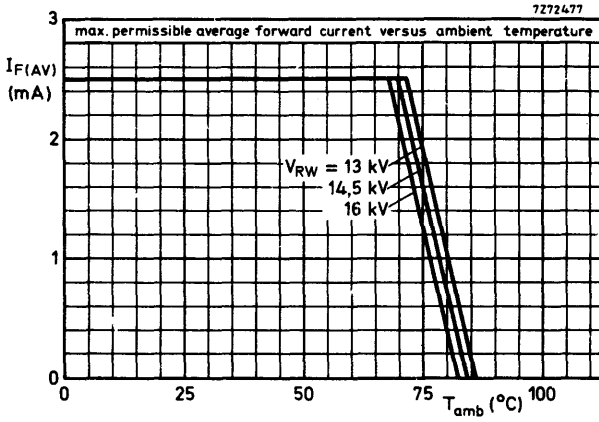

When used at voltages above 9 kV diode should be potted in such a way that $R_{th \text{ j-a}}$ is less than $120 \text{ }^\circ\text{C/W}$.

Typical operating circuit

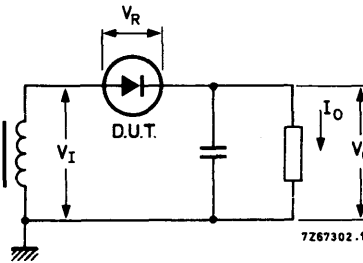

Typical applied voltage

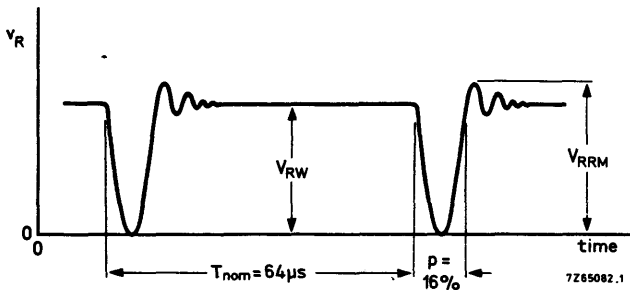

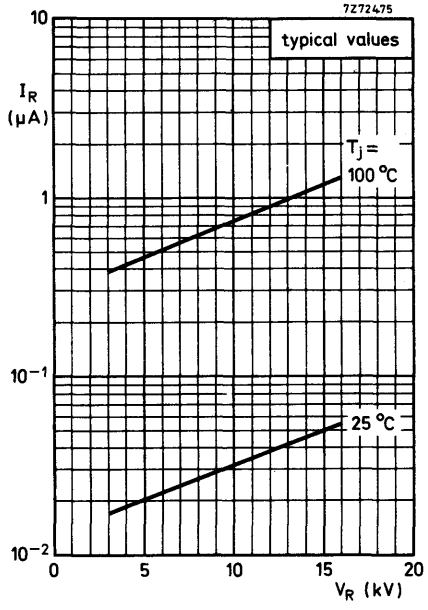
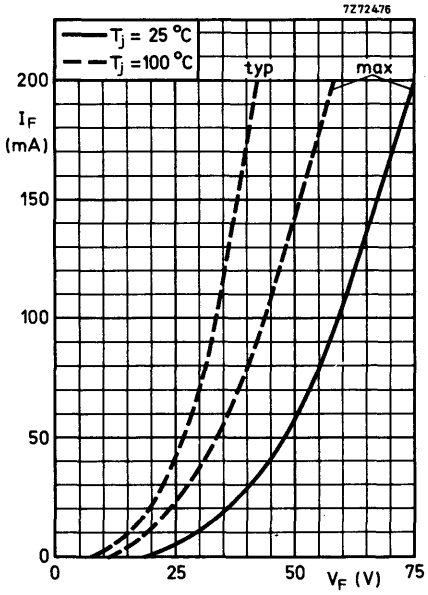

SILICON E.H.T. SOFT-RECOVERY RECTIFIER DIODE

E.H.T. rectifier diode in a glass envelope intended for use in high-voltage applications such as multipliers, e.g. tripler circuits, diode-split transformers. The device features non-snap-off characteristics. Because of the smallness of the envelope, the diodes should be used in a suitable dielectric medium (resin, oil, SF6 gas).

QUICK REFERENCE DATA

Working reverse voltage	V_{RW}	max.	11,5 kV
Repetitive peak reverse voltage	V_{RRM}	max.	12,5 kV
Average forward current	$I_{F(AV)}$	max.	4 mA
Junction temperature	T_j	max.	120 °C
Reverse recovery charge	Q_s	<	1 nC
Reverse recovery time	t_{rr}	typ.	0,2 μ s

MECHANICAL DATA

Dimensions in mm

Fig. 1 SOD-61.

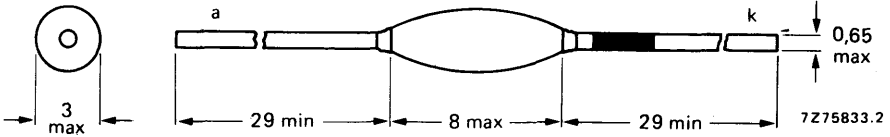

The cathode is indicated by a coloured band on the lead



RATINGS

Limiting values in accordance with the Absolute Maximum System (IEC 134).

Working reverse voltage	V_{RW}	max.	11,5 kV
Repetitive peak reverse voltage	V_{RRM}	max.	12,5 kV
Non-repetitive peak reverse voltage; $t \leq 10$ ms	V_{RSM}	max.	12,5 kV
Average forward current (averaged over any 20 ms period)	$I_F(AV)$	max.	4 mA
Repetitive peak forward current	I_{FRM}	max.	500 mA*
Storage temperature	T_{stg}		-65 to +120 °C
Junction temperature	T_j	max.	120 °C

CHARACTERISTICS

Forward voltage

$I_F = 100$ mA; $T_j = 120$ °C

$V_F < 43$ V**

Reverse current

$V_R = 11,5$ kV; $T_j = 120$ °C

$I_R < 3$ μ A

Reverse recovery when switched from

$I_F = 100$ mA to $V_R \geq 100$ V with $-dI_F/dt = 200$ mA/ μ s; $T_j = 25$ °C

recovery charge

$Q_s < 1$ nC

recovery time

t_{rr} typ. 0,2 μ s

fall time

$t_f > 0,1$ μ s

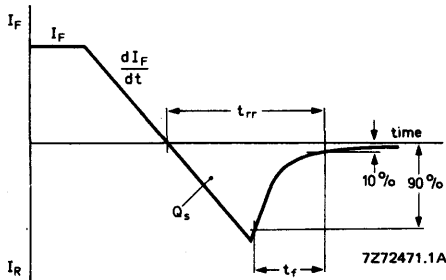

Fig. 2 Definitions of Q_s , t_{rr} and t_f .

* The device can withstand peak currents occurring at flashover in the picture tube.

** Measured under pulse conditions to avoid excessive dissipation.

7Z82239

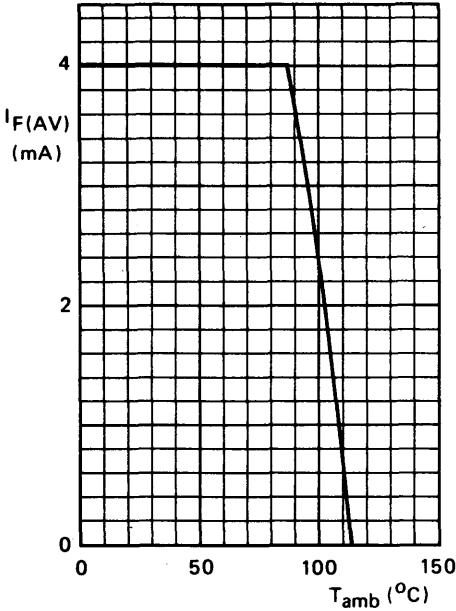

Fig. 3 Maximum permissible average forward current as a function of ambient temperature. $V_R = V_{RWmax}$. The device should be mounted in such a way that $R_{thj-a} \leq 120^{\circ}C/W$.

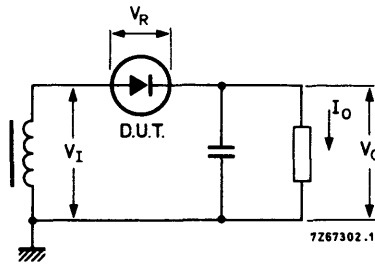

Fig. 4 Typical operation circuit.

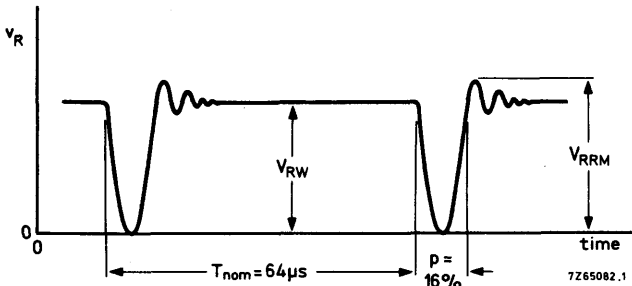

Fig. 5 Typical applied voltage.

7Z82240

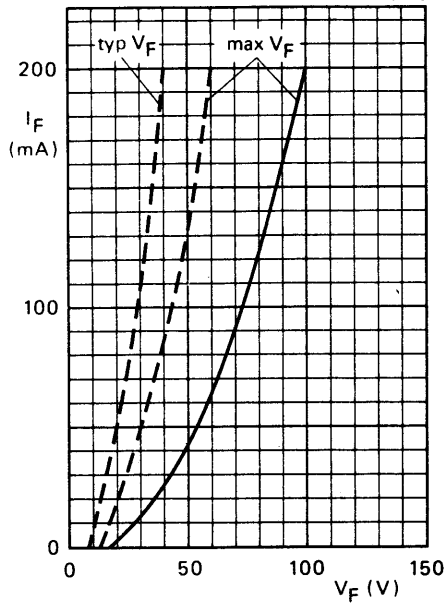

Fig. 6 — $T_j = 25^\circ\text{C}$; --- $T_j = 120^\circ\text{C}$.

EPITAXIAL AVALANCHE DIODES

Glass passivated epitaxial rectifier diodes in hermetically sealed axial-leaded glass envelopes. They feature low forward voltage drop, very fast recovery, very low stored charge, non-snap-off switching characteristics and are capable of absorbing reverse transient energy (e.g. during flashover in a picture tube). These properties make the diodes very suitable for use in switched-mode power supplies and in general high-frequency circuits, where low conduction and switching losses are essential.

QUICK REFERENCE DATA

		BYV27-50	100	150	200
Repetitive peak reverse voltage	V_{RRM}	max. 50	100	150	200 V
Continuous reverse voltage	V_R	max. 50	100	150	200 V
Average forward current	$I_{F(AV)}$	max.	2		A
Non-repetitive peak reverse energy	E_{RSM}	max.	20		mJ
Reverse recovery time	t_{rr}	<	25		ns

MECHANICAL DATA

Dimensions in mm

Fig. 1 SOD-57. The diodes are type branded

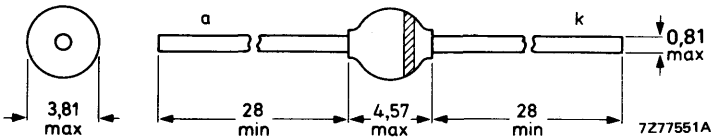

The marking band indicates the cathode.

Marking: BYV27-50 = BYV27-5
 BYV27-100 = BYV2710
 BYV27-150 = BYV2715
 BYV27-200 = BYV2720



RATINGS

Limiting values in accordance with the Absolute Maximum System (IEC 134)

		BYV27-50	100	150	200
Repetitive peak reverse voltage	V_{RRM}	max. 50	100	150	200 V
Continuous reverse voltage	V_R	max. 50	100	150	200 V
Average forward current (averaged over any 20 ms period) $T_{tp} = 75\text{ }^\circ\text{C}$; lead length = 10 mm $T_{amb} = 60\text{ }^\circ\text{C}$; Fig. 2	$I_{F(AV)}$	max.		2	A
	$I_{F(AV)}$	max.		1,25	A
Repetitive peak forward current	I_{FRM}	max.		15	A
Non-repetitive peak forward current ($t = 10\text{ ms}$; half sine-wave) $T_j = T_j\text{ max}$ prior to surge; with reapplied V_{RRM}	I_{FSM}	max.		50	A
Non-repetitive peak reverse avalanche energy; $I_R = 600\text{ mA}$; $T_j = T_j\text{ max}$ prior to surge; with inductive load switched off	E_{RSM}	max.		20	mJ
Storage temperature	T_{stg}		-65 to + 175		$^\circ\text{C}$
Junction temperature	T_j	max.		165	$^\circ\text{C}$

THERMAL RESISTANCE

Influence of mounting method

1. Thermal resistance from junction to tie-point at a lead length of 10 mm
 $R_{th\ j-tp} = \quad = \quad \quad \quad 46 \quad \quad \quad ^\circ\text{C/W}$
2. Thermal resistance from junction to ambient when mounted on a 1,5 mm thick epoxy-glass printed-circuit board; Cu-thickness $\geq 40\text{ }\mu\text{m}$; Fig. 2
 $R_{th\ j-a} = \quad = \quad \quad \quad 100 \quad \quad \quad ^\circ\text{C/W}$

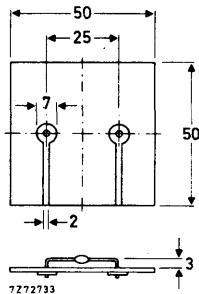

Fig. 2 Mounted on a printed-circuit board.



CHARACTERISTICS

$T_j = 25\text{ }^\circ\text{C}$ unless otherwise specified

	BYV27-50	100	150	200	
Reverse avalanche breakdown voltage $I_R = 0,1\text{ mA}$	$V_{(BR)R}$	55	110	165	220
Forward voltage* $I_F = 2,5\text{ A}; T_j = T_{j\text{ max}}$	V_F	<	0,85	V	
$I_F = 5\text{ A}$	V_F	<	1,25	V	
Reverse current $V_R = V_{RRM\text{ max}}; T_j = 25\text{ }^\circ\text{C}$	I_R	<	1	μA	
$V_R = V_{RRM\text{ max}}; T_j = 165\text{ }^\circ\text{C}$	I_R	<	150	μA	
Reverse recovery time when switched from $I_F = 0,5\text{ A}$ to $I_R = 1\text{ A}$; measured at $I_R = 0,25\text{ A}$ for definition see Figs 3 and 4	t_{rr}	<	25	ns	

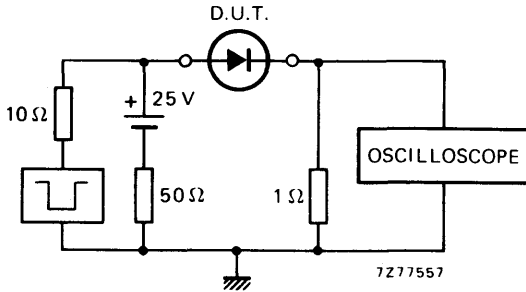

Fig. 3 Test circuit.
Input impedance oscilloscope $1\text{ M}\Omega$; 22 pF . Rise time $\leq 7\text{ ns}$.
Source impedance $50\text{ }\Omega$. Rise time $\leq 15\text{ ns}$.

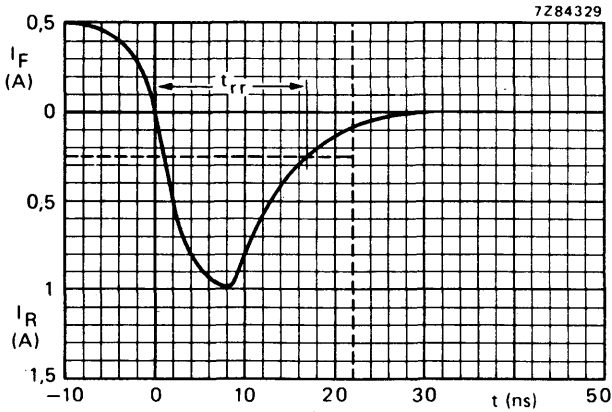

Fig. 4 Reverse recovery time characteristic.

* Measured under pulse conditions to avoid excessive dissipation.



Reverse recovery when switched from

$I_F = 1 \text{ A}$ to $V_R \geq 30 \text{ V}$ with
 $-dI_F/dt = 20 \text{ A}/\mu\text{s}$ (see Fig. 5)
 recovered charge
 recovery time

$Q_S < 15 \text{ nC}$
 $t_{rr} < 50 \text{ ns}$

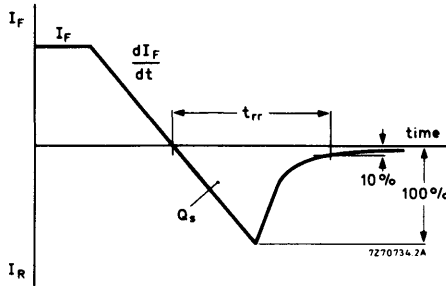

Fig. 5 Definitions of t_{rr} and Q_S .

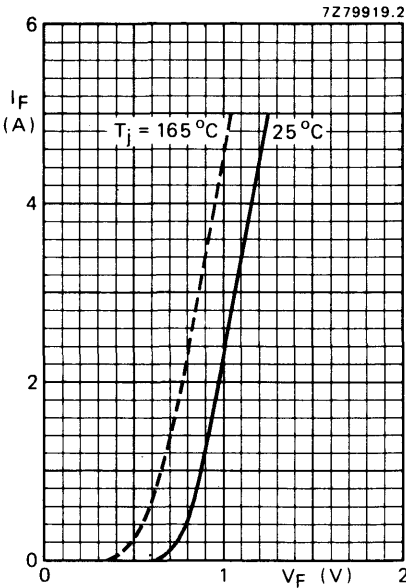

Fig. 6 Forward current as a function of the maximum forward voltage.

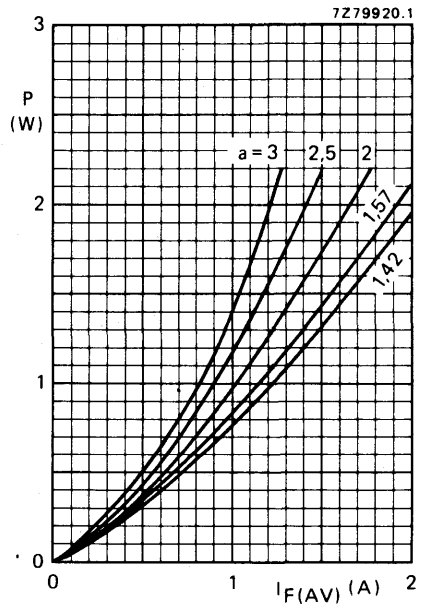

Fig. 7 Power dissipation (forward plus leakage current) as a function of the average forward current. Pulsed reverse voltage; $\delta = 50\%$.
 $a = I_F(\text{RMS})/I_F(\text{AV})$; $V_R = V_{RRM\text{max}}$.



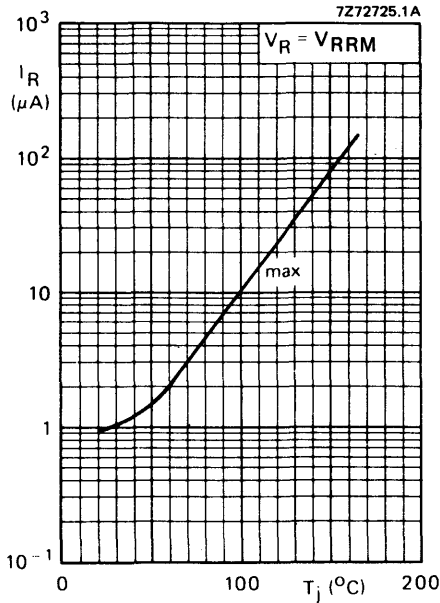

Fig. 8 Reverse current as a function of the junction temperature.

OPERATING NOTES

The various components of junction temperature rise above ambient, for mounting with symmetrical lead length, are illustrated on page 6.

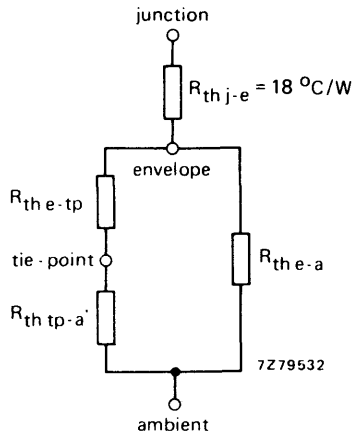

Fig. 9 Thermal model.



The thermal resistances between envelope and tie-point, and between envelope and ambient depend on lead length.

thermal resistance	lead length					unit
	5	10	15	20	25	mm
$R_{th\ e-tp}$	15	30	45	60	75	$^{\circ}C/W$
$R_{th\ e-a}$	580	445	350	290	245	$^{\circ}C/W$

The thermal resistance between tie-point and ambient depends on the mounting method; for mounting on a 1,5 mm thick epoxy-glass printed-circuit board with a copper-thickness $\geq 40\ \mu m$, the following values apply:

1. Mounting similar to method given in Fig. 2: $R_{th\ tp-a} = 70\ ^{\circ}C/W$.
2. Mounted on a printed-circuit board with a copper laminate (per lead) of:

- 1 cm² $R_{th\ tp-a} = 55\ ^{\circ}C/W$
- 2,25 cm² $R_{th\ tp-a} = 45\ ^{\circ}C/W$

Note

Any temperature can be calculated by using the dissipation graph (Fig. 7) and the thermal model (Fig. 9).



EPITAXIAL AVALANCHE DIODES

Glass passivated epitaxial rectifier diodes in hermetically sealed axial-leaded glass envelopes. They feature low forward voltage drop, very fast recovery, very low stored charge, non-snap-off switching characteristics and are capable of absorbing reverse transient energy (e.g. during flashover in a picture tube). These properties make the diodes very suitable for use in switched-mode power supplies and in general in high-frequency circuits, where low conduction and switching losses are essential.

QUICK REFERENCE DATA

		BYV28-50	100	150	200
Repetitive peak reverse voltage	V_{RRM}	max. 50	100	150	200 V
Continuous reverse voltage	V_R	max. 50	100	150	200 V
Average forward current	$I_F(AV)$	max.	3,5		A
Non-repetitive peak reverse energy	E_{RSM}	max.	20		mJ
Reverse recovery time	t_{rr}	<	30		ns

MECHANICAL DATA

Dimensions in mm

Fig. 1 SOD-64. The diodes are type-branded

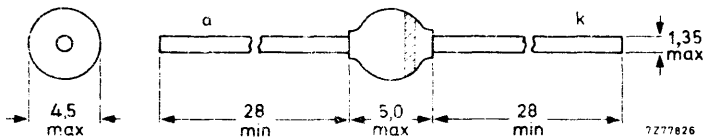

The marking band indicates the cathode.



RATINGS

Limiting values in accordance with the Absolute Maximum System (IEC 134)

		BYV28-50	100	150	200
Repetitive peak reverse voltage	V_{RRM}	max. 50	100	150	200 V
Continuous reverse voltage	V_R	max. 50	100	150	200 V
Average forward current (averaged over any 20 ms period)					
$T_{tp} = 75\text{ }^\circ\text{C}$; lead length = 10 mm	$I_{F(AV)}$	max.	3,5		A
$T_{amb} = 60\text{ }^\circ\text{C}$; p.c.b. mounting (see Fig. 2)	$I_{F(AV)}$	max.	1,8		A
Repetitive peak forward current	I_{FRM}	max.	25		A
Non-repetitive peak forward current (t = 10 ms; half sine-wave) $T_j = T_{j\text{ max}}$ prior to surge; with reapplied V_{RRM}	I_{FSM}	max.	80		A
Non-repetitive peak reverse avalanche energy; $I_R = 600\text{ mA}$; $T_j = T_{j\text{ max}}$ prior to surge; with inductive load switched off	E_{RSM}	max.	20		mJ
Storage temperature	T_{stg}		-65 to + 175		$^\circ\text{C}$
Junction temperature	T_j	max.	165		$^\circ\text{C}$

THERMAL RESISTANCE

Influence of mounting method

1. Thermal resistance from junction to tie-point at a lead length of 10 mm
 $R_{th\ j-tp} = 25\text{ }^\circ\text{C/W}$
2. Thermal resistance from junction to ambient when mounted on a 1,5 mm thick epoxy-glass printed-circuit board; Cu-thickness $\geq 40\text{ }\mu\text{m}$; Fig. 2
 $R_{th\ j-a} = 75\text{ }^\circ\text{C/W}$

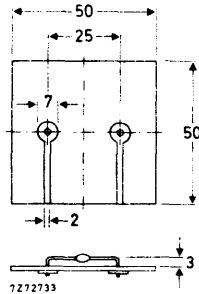

Fig. 2 Mounted on a printed-circuit board.



CHARACTERISTICS

$T_j = 25\text{ }^\circ\text{C}$, unless otherwise specified

Reverse avalanche breakdown voltage

$I_R = 0,1\text{ mA}$

	BYV28-50	100	150	200
$V_{(BR)R} >$	55	110	165	220 V

Forward voltage*

$I_F = 3\text{ A}; T_j = T_{j\text{ max}}$

$I_F = 5\text{ A}$

$V_F <$		0,75		V
$V_F <$		1,10		V

Reverse current

$V_R = V_{RRM\text{ max}}; T_j = 25\text{ }^\circ\text{C}$

$V_R = V_{RRM\text{ max}}; T_j = 165\text{ }^\circ\text{C}$

$I_R <$		1		μA
$I_R <$		150		μA

Reverse recovery time when switched from

$I_F = 0,5\text{ A}$ to $I_R = 1\text{ A}$; measured at

$I_R = 0,25\text{ A}$ for definition see

Figs 3 and 4

$t_{rr} <$		30		ns
------------	--	----	--	----

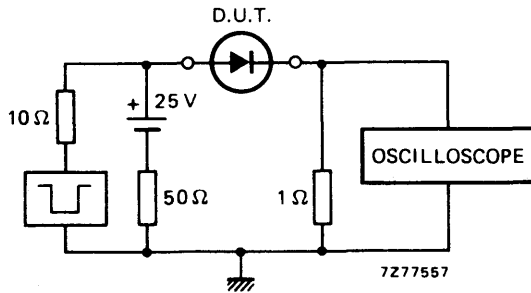

Fig. 3 Test circuit.

Input impedance oscilloscope $1\text{ M}\Omega; 22\text{ pF}$; Rise time $\leq 7\text{ ns}$.
Source impedance $50\text{ }\Omega$. Rise time $\leq 15\text{ ns}$.

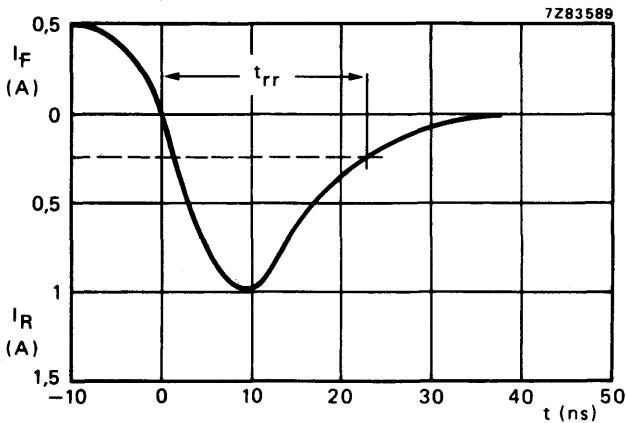

Fig. 4 Reverse recovery time characteristic.

* Measured under pulse conditions to avoid excessive dissipation.



Reverse recovery when switched from

$I_F = 1 \text{ A}$ to $V_R \geq 30 \text{ V}$ with
 $-dI_F/dt = 20 \text{ A}/\mu\text{s}$ (see Fig. 5)
 recovered charge
 recovery time

$Q_s < 20 \text{ nC}$
 $t_{rr} < 50 \text{ ns}$

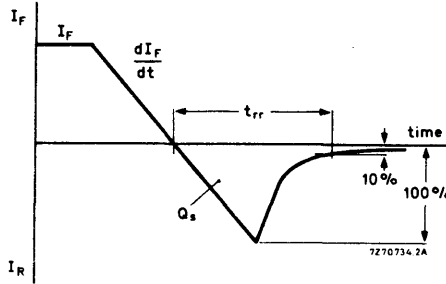

Fig. 5 Definitions of t_{rr} and Q_s .

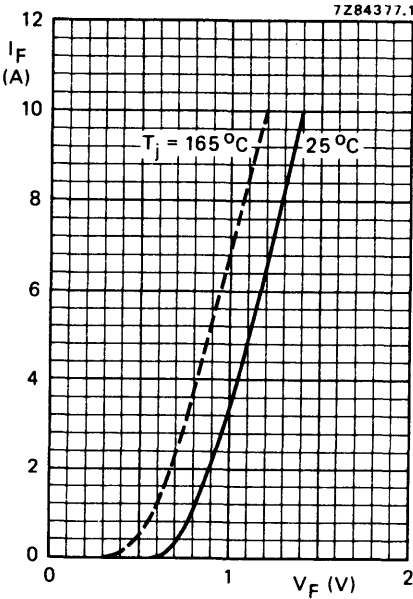

Fig. 6 Forward current as a function of the maximum forward voltage.

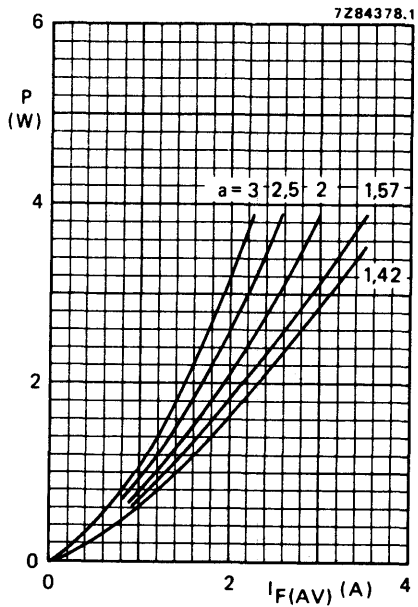

Fig. 7 Power dissipation (forward plus leakage current) as a function of the average forward current. Pulsed reverse voltage; $\delta = 50\%$.
 $a = I_F(\text{RMS})/I_F(\text{AV})$; $V_R = V_{RRMmax}$.



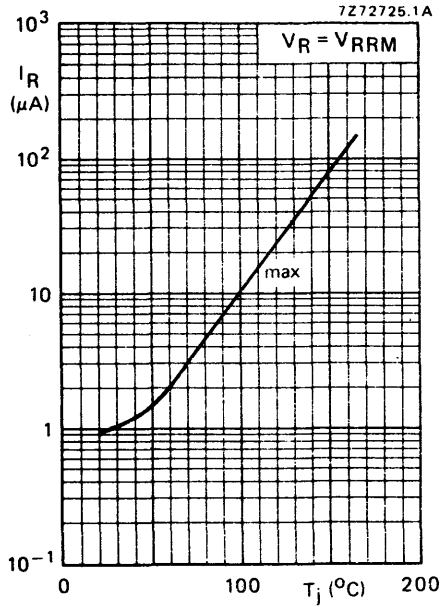

Fig. 8 Reverse current as a function of the junction temperature.

OPERATING NOTES

The various components of junction temperature rise above ambient, for mounting with symmetrical lead length, are illustrated on page 6.

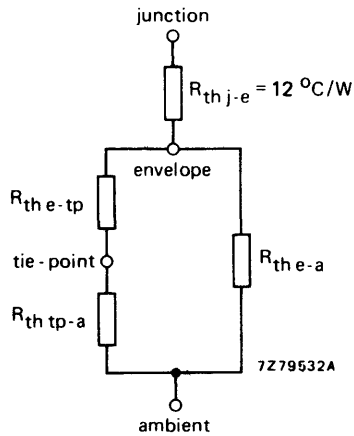

Fig. 9 Thermal model.



The thermal resistances between envelope and tie-point, and between envelope and ambient depend on lead length.

thermal resistance	lead length					unit
	5	10	15	20	25	mm
$R_{th\ e-tp}$	7	14	21	28	35	$^{\circ}C/W$
$R_{th\ e-a}$	410	300	230	185	155	$^{\circ}C/W$

The thermal resistance between tie-point and ambient depends on the mounting method; for mounting on a 1,5 mm thick epoxy-glass printed-circuit board with a copper thickness $\geq 40\ \mu m$, the following values apply:

1. Mounting similar to method given in Fig. 2: $R_{th\ tp-a} = 70\ ^{\circ}C/W$.
2. Mounted on a printed-circuit board with a copper laminate (per lead) of:
 - 1 cm² $R_{th\ tp-a} = 55\ ^{\circ}C/W$
 - 2,25 cm² $R_{th\ tp-a} = 45\ ^{\circ}C/W$.

Note

Any temperature can be calculated by using the dissipation graph (Fig. 7) and the thermal model (Fig. 9).



AVALANCHE FAST SOFT-RECOVERY RECTIFIER DIODES

Glass passivated rectifier diodes in hermetically sealed axial-leaded glass envelopes. They are intended for television and industrial applications, such as switched-mode power supplies, scan rectifiers in TV receivers, and also for use in inverter and converter applications. The devices feature non-snap-off (soft-recovery) switching characteristics and are capable of absorbing reverse transient energy (e.g. during flashover in the picture tube).

QUICK REFERENCE DATA

		BYV95A	B	C
Repetitive peak reverse voltage	V_{RRM} max.	200	400	600 V
Continuous reverse voltage	V_R max.	200	400	600 V
Average forward current	$I_F(AV)$ max.		1,5	A
Non-repetitive peak forward current	I_{FSM} max.		35	A
Non-repetitive peak reverse energy	E_{RSM} max.		10	mJ
Reverse recovery time	t_{rr} <		250	ns

MECHANICAL DATA

Dimensions in mm

Fig. 1 SOD-57.

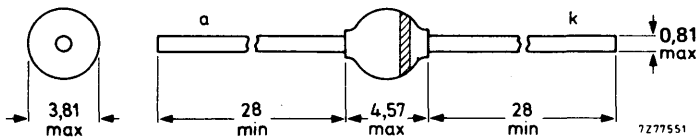

The marking band indicates the cathode.

The diodes are type-branded



RATINGS

Limiting values in accordance with the Absolute Maximum System (IEC 134)

		BYV95A	B	C
Repetitive peak reverse voltage	V_{RRM} max.	200	400	600 V
Continuous reverse voltage	V_R max.	200	400	600 V
Average forward current (averaged over any 20 ms period) $T_{tp} = 55\text{ }^\circ\text{C}$; lead length 10 mm $T_{amb} = 55\text{ }^\circ\text{C}$; Fig. 2	$I_{F(AV)}$ max.		1,5	A
	$I_{F(AV)}$ max.		0,8	A
Repetitive peak forward current	I_{FRM} max.		10	A
Non-repetitive peak forward current ($t = 10\text{ ms}$; half sine-wave) $T_j = T_j\text{ max}$ prior to surge; $V_R = V_{RRM\text{max}}$	I_{FSM} max.		35	A
Non-repetitive peak reverse avalanche energy; $I_R = 400\text{ mA}$; $T_j = T_j\text{ max}$ prior to surge; with inductive load switched off	E_{RSM} max.		10	mJ
Storage temperature	T_{stg}	-65 to + 175		$^\circ\text{C}$
Operating junction temperature	T_j max.	165		$^\circ\text{C}$

THERMAL RESISTANCE

Influence of mounting method

1. Thermal resistance from junction to tie-point at a lead length of 10 mm
 $R_{th\ j-tp} =$ 46 $^\circ\text{C/W}$
2. Thermal resistance from junction to ambient when mounted on a 1,5 mm thick epoxy-glass printed-circuit board; Cu-thickness $\geq 40\text{ }\mu\text{m}$; Fig. 2
 $R_{th\ j-a} =$ 100 $^\circ\text{C/W}$

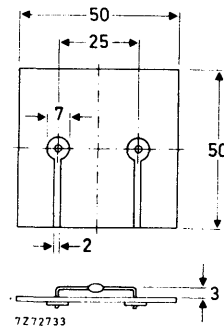

Fig. 2 Mounted on a printed-circuit board.



CHARACTERISTICS

$T_j = 25\text{ }^\circ\text{C}$ unless otherwise specified

Forward voltage

$I_F = 3\text{ A}$

$I_F = 3\text{ A}; T_j = 165\text{ }^\circ\text{C}$

Reverse avalanche breakdown voltage

$I_R = 0,1\text{ mA}$

Reverse current

$V_R = V_{RRMmax}; T_j = 165\text{ }^\circ\text{C}$

Reverse recovery when switched from

$I_F = 1\text{ A}$ to $V_R \geq 30\text{ V}$ with

$-di_F/dt = 20\text{ A}/\mu\text{s}$

recovered charge

recovery time

Maximum slope of reverse recovery current when switched from $I_F = 1\text{ A}$ to $V_R \geq 30\text{ V}$ with $-di_F/dt = 1\text{ A}/\mu\text{s}$

	BYV95A	B	C
$V_F <$	1,6	1,6	1,6 V *
$V_F <$	1,35	1,35	1,35 V *
$V_{(BR)R} >$	300	500	700 V
$I_R <$		150	μA
$Q_s <$		250	nC
$t_{rr} <$		250	ns
$ di_R/dt <$		6	A/ μs

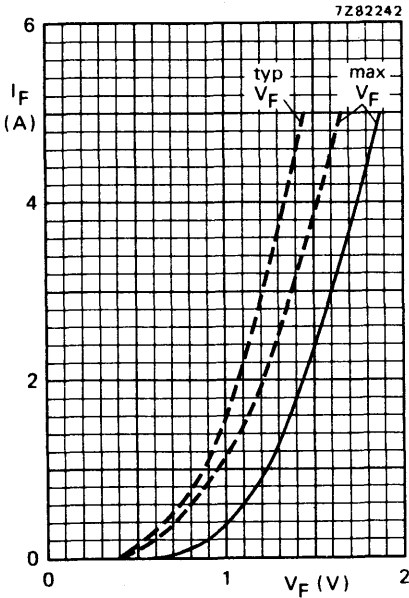

Fig. 3 — $T_j = 25\text{ }^\circ\text{C}$; --- $T_j = 165\text{ }^\circ\text{C}$.

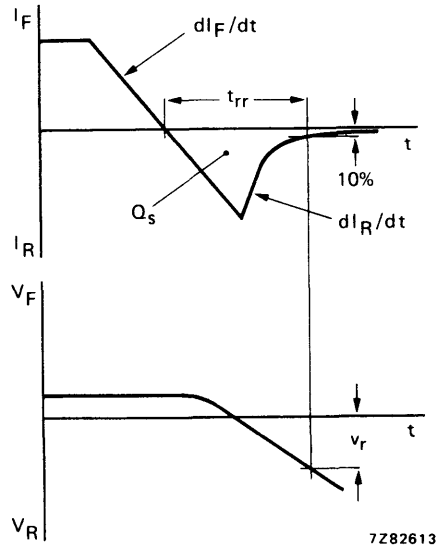

Fig. 4 Definitions.

* Measured under pulse conditions to avoid excessive dissipation.



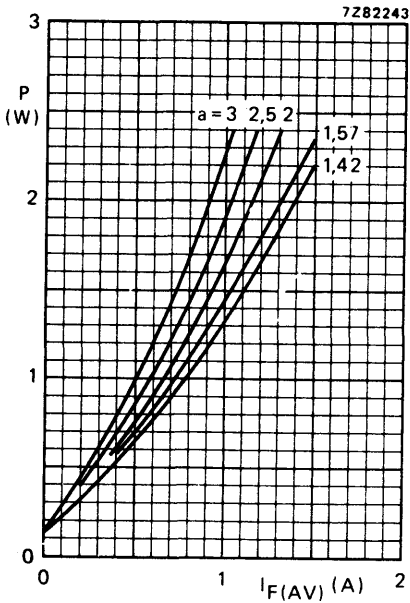

Fig. 5 Steady state power dissipation (forward plus leakage current) excluding switching losses as a function of the average forward current.

The graph is for switched-mode application.

$$a = I_{F(RMS)}/I_{F(AV)}; V_R = V_{RRMmax}$$

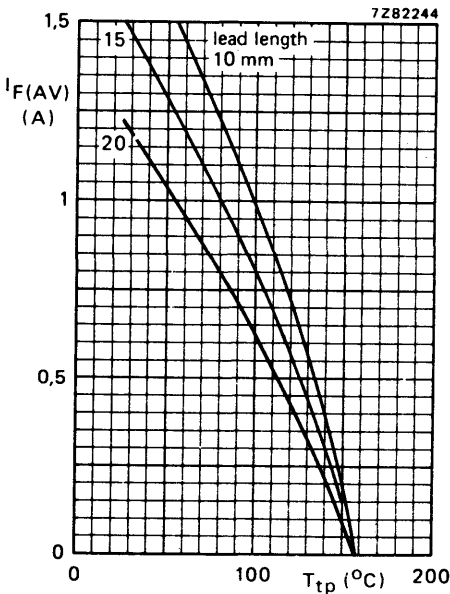
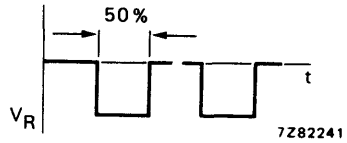

Fig. 6 Maximum average forward current as a function of the tie-point temperature; the curves include losses due to reverse leakage.

The graph is for switched-mode application; $V_R = V_{RRMmax}$; $\delta = 50\%$; $a = 1.57$.



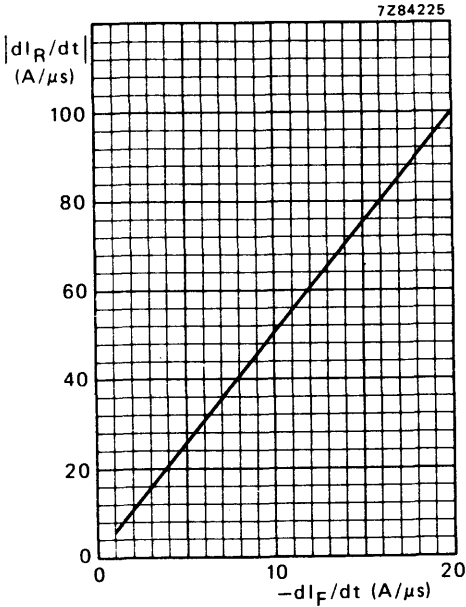

Fig. 7 Maximum slope of reverse recovery current. $T_j = 25^\circ\text{C}$.

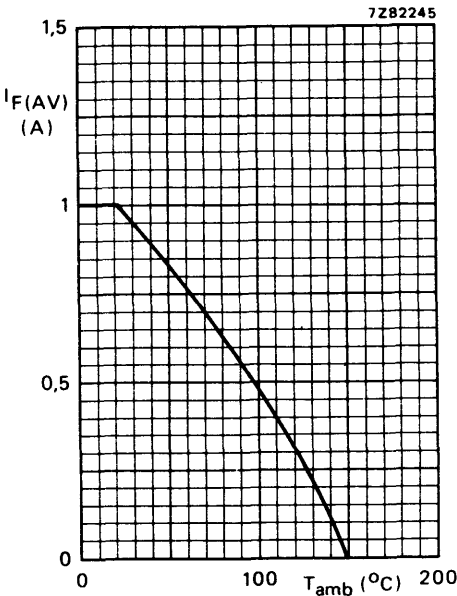

Fig. 8 Maximum average forward current as a function of the ambient temperature; the curve includes losses due to reverse leakage. Mounting method see Fig. 2. The graph is for switched-mode application. $V_R = V_{RRMmax}$; $\delta = 50\%$; $a = 1,57$.



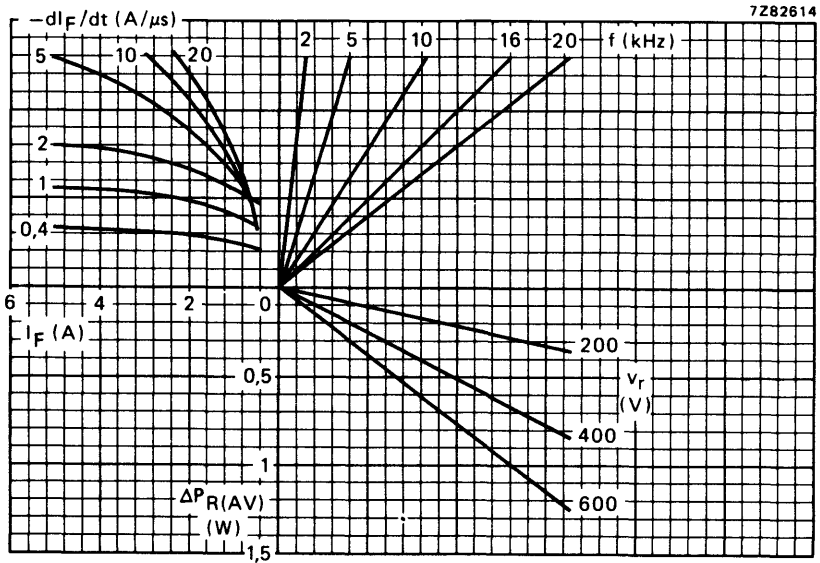

Fig. 9 Nomogram: power loss ($\Delta P_R(AV)$) due to switching only. To be added to steady state power losses (see also Fig. 4).

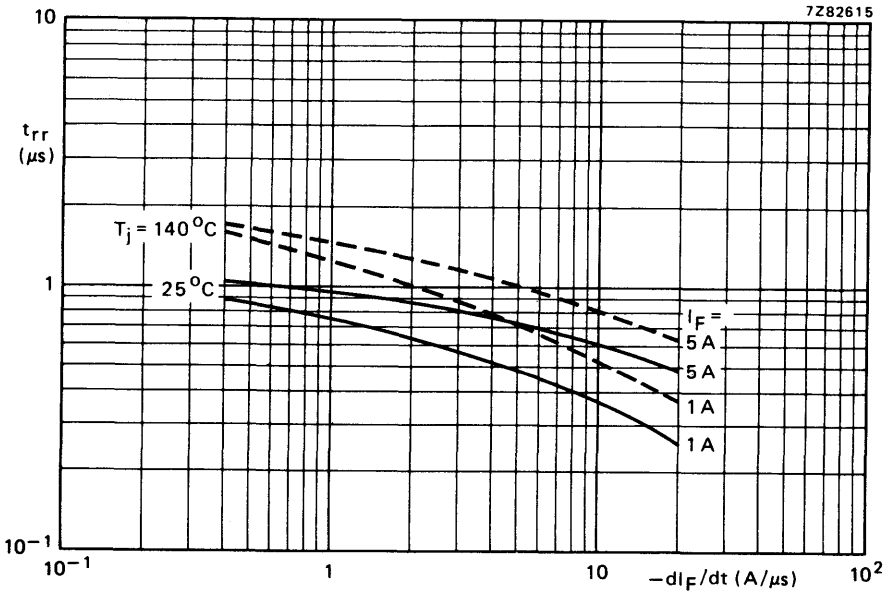

Fig. 10 Maximum values (see also Fig. 4).



7Z82616

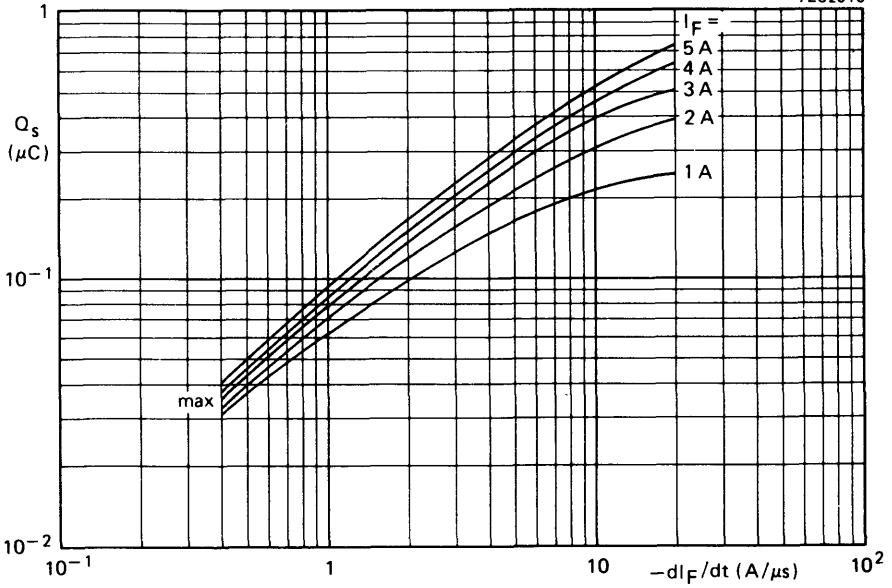

Fig. 11 Maximum values at $T_j = 25^\circ\text{C}$ (see also Fig. 4).

7Z82624

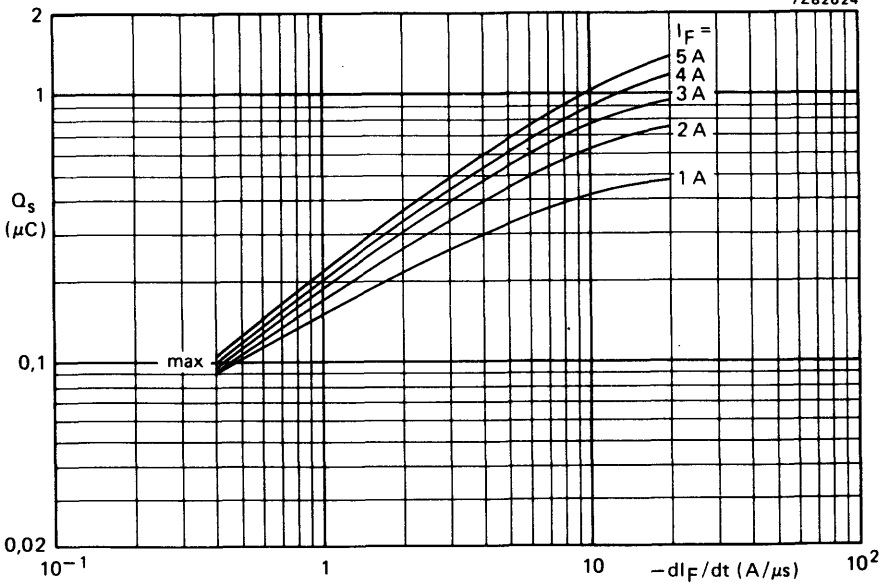

Fig. 12 Maximum values at $T_j = 140^\circ\text{C}$ (see also Fig. 4).



OPERATING NOTES

The various components of junction temperature rise above ambient, for mounting with symmetrical lead length, are illustrated below.

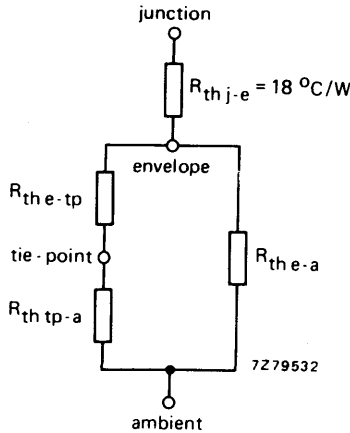

Fig. 13.

The thermal resistances between envelope and tie-point, and between envelope and ambient depend on lead length.

lead length	5	10	15	20	25	mm
$R_{th\ e-tp}$	15	30	45	60	75	°C/W
$R_{th\ e-a}$	580	445	350	290	245	°C/W

The thermal resistance between tie-point and ambient depends on the mounting method; for mounting on a 1,5 mm thick epoxy-glass printed-circuit board with a copper-thickness $\geq 40\ \mu\text{m}$, the following values apply:

1. Mounting similar to method given in Fig. 2: $R_{th\ tp-a} = 70\ \text{°C/W}$
2. Mounted on a printed-circuit board with copper laminate (per lead) of:
 - 1 cm² $R_{th\ tp-a} = 55\ \text{°C/W}$
 - 2,25 cm² $R_{th\ tp-a} = 45\ \text{°C/W}$

Note

Any temperature can be calculated by using the dissipation graph (Fig. 5) and the above thermal model.



AVALANCHE FAST SOFT-RECOVERY RECTIFIER DIODES

Glass passivated rectifier diodes in hermetically sealed axial-leaded glass envelopes. They are intended for television and industrial applications, such as switched-mode power supplies, scan rectifiers in TV receivers, and also for use in inverter and converter applications. The devices feature non-snap-off (soft-recovery) switching characteristics and are capable of absorbing reverse transient energy (e.g. during flashover in the picture tube).

QUICK REFERENCE DATA

		BYV96D	BYV96E
Repetitive peak reverse voltage	V_{RRM}	max. 800	1000 V
Continuous reverse voltage	V_R	max. 800	1000 V
Average forward current	$I_F(AV)$	max. 1,5	A
Non-repetitive peak forward current	I_{FSM}	max. 35	A
Non-repetitive peak reverse energy	E_{RSM}	max. 10	mJ
Reverse recovery time	t_{rr}	< 300	ns

MECHANICAL DATA

Dimensions in mm

Fig. 1 SOD-57.

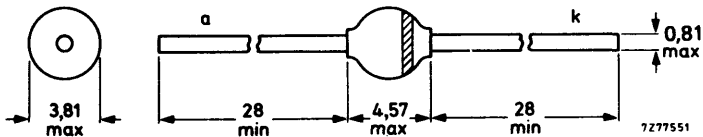

The marking band indicates the cathode.

The diodes are type-branded



RATINGS

Limiting values in accordance with the Absolute Maximum System (IEC 134)

		BYV96D	BYV96E
Repetitive peak reverse voltage	V_{RRM}	max. 800	1000 V
Continuous reverse voltage	V_R	max. 800	1000 V
Average forward current (averaged over any 20 ms period)			
$T_{TP} = 55\text{ }^\circ\text{C}$; lead length 10 mm	$I_{F(AV)}$	max. 1,5	A
$T_{amb} = 55\text{ }^\circ\text{C}$; Fig. 2	$I_{F(AV)}$	max. 0,8	A
Repetitive peak forward current	I_{FRM}	max. 10	A
Non-repetitive peak forward current ($t = 10\text{ ms}$; half sine-wave) $T_j = T_j\text{ max}$ prior to surge; $V_R = V_{RRM}\text{ max}$	I_{FSM}	max. 35	A
Non-repetitive peak reverse avalanche energy; $I_R = 400\text{ mA}$; $T_j = T_j\text{ max}$ prior to surge; with inductive load switched off	E_{RSM}	max. 10	mJ
Storage temperature	T_{stg}	-65 to +175	$^\circ\text{C}$
Operating junction temperature	T_j	max. 165	$^\circ\text{C}$

THERMAL RESISTANCE

Influence of mounting method

1. Thermal resistance from junction to tie-point at a lead length of 10 mm
 $R_{th\ j-tp} = 46\text{ }^\circ\text{C/W}$
2. Thermal resistance from junction to ambient when mounted on a 1,5 mm thick epoxy-glass printed-circuit board; Cu-thickness $\geq 40\text{ }\mu\text{m}$; Fig. 2
 $R_{th\ j-a} = 100\text{ }^\circ\text{C/W}$

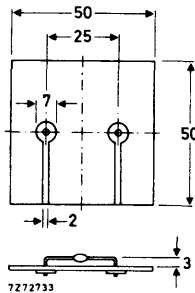

Fig. 2 Mounted on a printed-circuit board.



CHARACTERISTICS

$T_j = 25\text{ }^\circ\text{C}$ unless otherwise specified

Forward voltage

$I_F = 3\text{ A}$

$I_F = 3\text{ A}; T_j = 165\text{ }^\circ\text{C}$

Reverse avalanche breakdown voltage

$I_R = 0,1\text{ mA}$

Reverse current

$V_R = V_{RRM\text{ max}}; T_j = 165\text{ }^\circ\text{C}$

Reverse recovery when switched from

$I_F = 1\text{ A}$ to $V_R \geq 30\text{ V}$ with

$-dI_F/dt = 20\text{ A}/\mu\text{s}$

recovered charge

recovery time

Maximum slope of reverse recovery current when switched from $I_F = 1\text{ A}$ to $V_R \geq 30\text{ V}$;
 $-dI_F/dt = 1\text{ A}/\mu\text{s}$

	BYV96D	BYV96E
V_F	< 1,6	1,6 V*
V_F	< 1,35	1,35 V*
$V_{(BR)R}$	> 900	1100 V
I_R	< 150	μA
Q_s	< 400	nC
t_{rr}	< 300	ns
$ dI_R/dt $	< 5	A/ μs

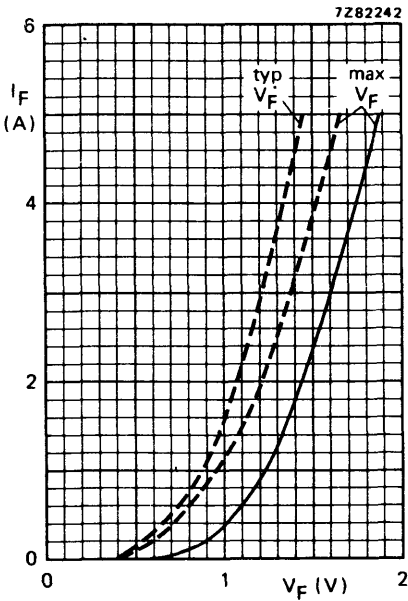

Fig. 3 — $T_j = 25\text{ }^\circ\text{C}$; --- $T_j = 165\text{ }^\circ\text{C}$.

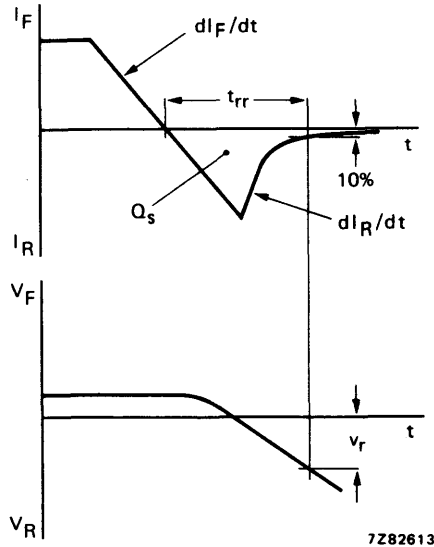

Fig. 4 Definitions of t_{rr} and Q_s .

* Measured under pulse conditions to avoid excessive dissipation.



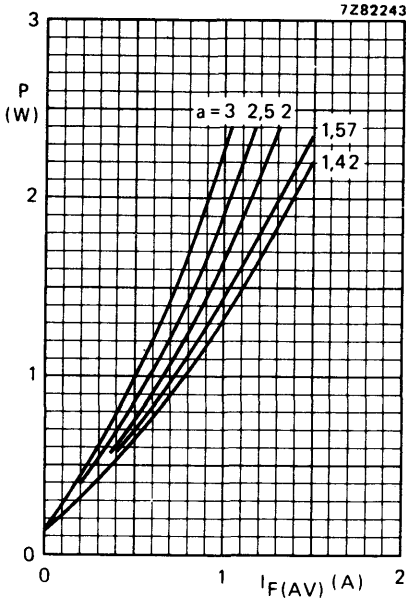

Fig. 5.

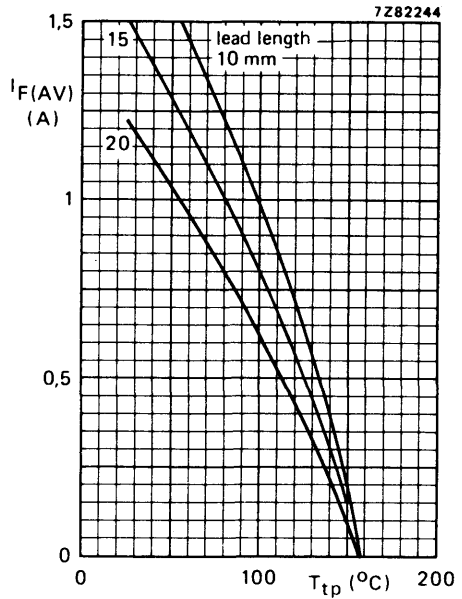

Fig. 6.

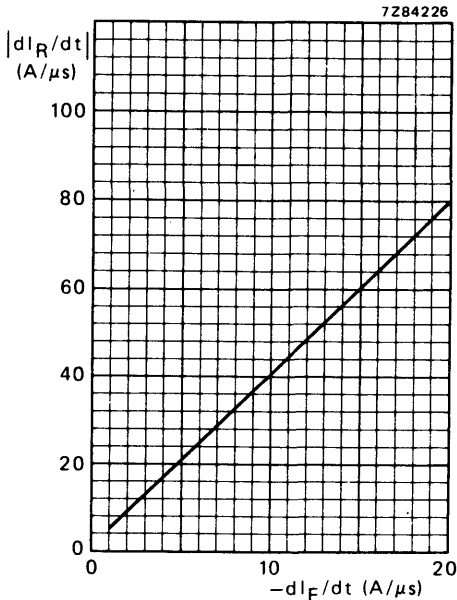

Fig. 7.

Fig. 5 Steady state power dissipation (forward plus leakage current) excluding switching losses as a function of the average forward current.

The graph is for switched-mode application.

$$a = I_{F(RMS)} / I_{F(AV)}; V_R = V_{RRM \max}$$

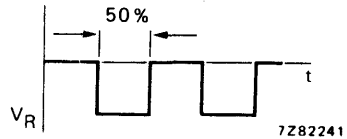

Fig. 6 Maximum average forward current as a function of the tie-point temperature; the curves include losses due to reverse leakage.

The graph is for switched-mode application; $V_R = V_{RRM \max}$; $\delta = 50\%$; $a = 1.57$.

Fig. 7 Maximum slope of reverse recovery current. $T_j = 25^\circ\text{C}$.



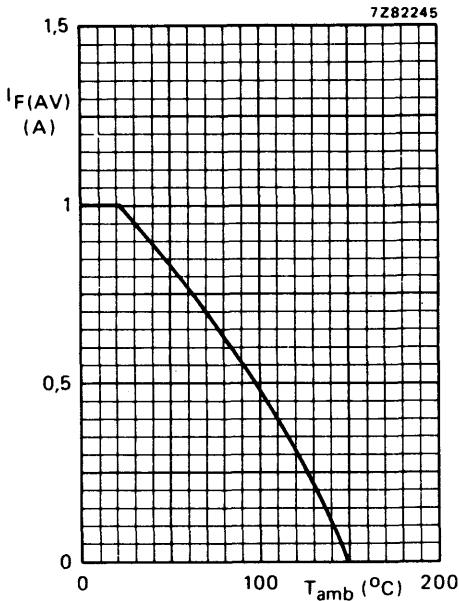

Fig. 8 Maximum average forward current as a function of the ambient temperature; the curve includes losses due to reverse leakage.

Mounting method see Fig. 2.

The graph is for switched-mode application.
 $V_R = V_{RRM \max}$; $\delta = 50\%$; $a = 1,57$.

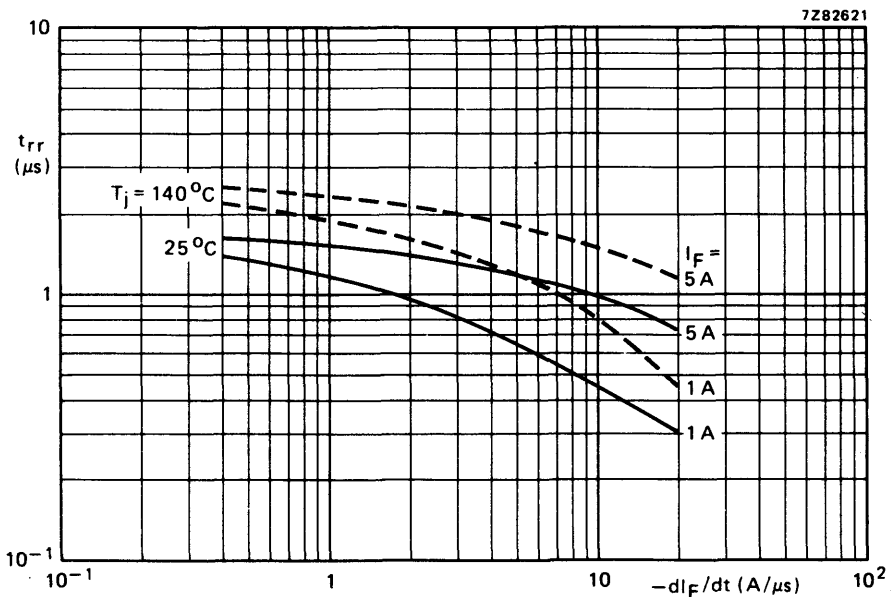

Fig. 9 Maximum values (see also Fig. 4).



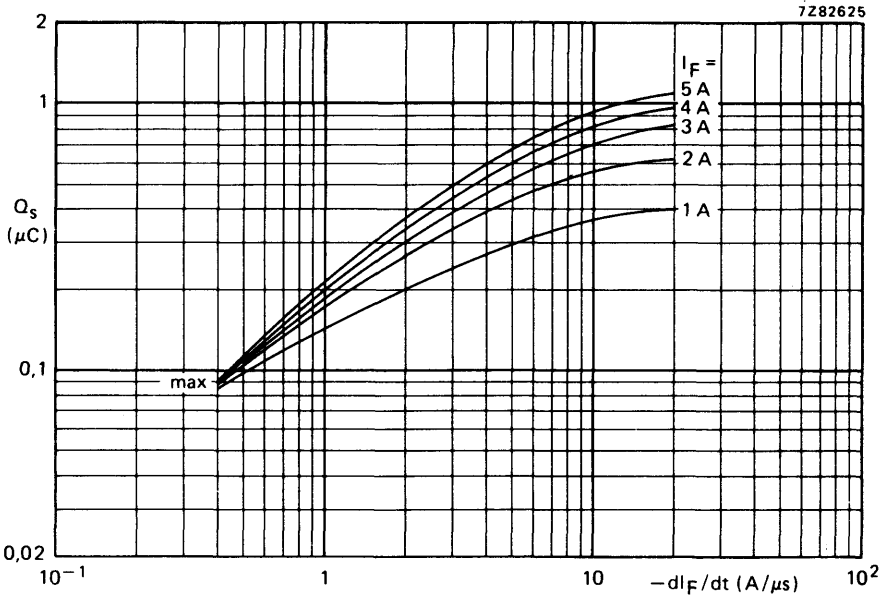

Fig. 10 Maximum values; $T_j = 25^\circ\text{C}$ (see also Fig. 4).

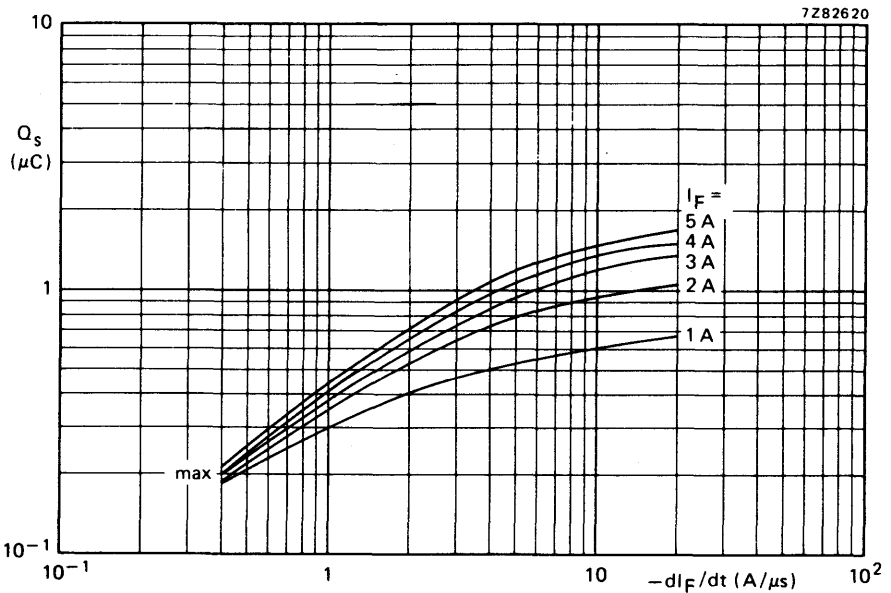

Fig. 11 Maximum values; $T_j = 140^\circ\text{C}$ (see also Fig. 4).



OPERATING NOTES

The various components of junction temperature rise above ambient, for mounting with symmetrical lead length, are illustrated below.

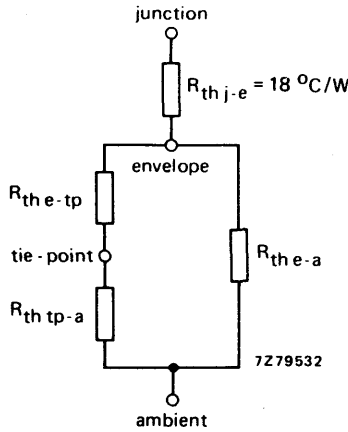

Fig. 12.

The thermal resistances between envelope and tie-point, and between envelope and ambient depend on lead length.

lead length	5	10	15	20	25	mm
$R_{th\ e-tp}$	15	30	45	60	75	°C/W
$R_{th\ e-a}$	580	445	350	290	245	°C/W

The thermal resistance between tie-point and ambient depends on the mounting method; for mounting on a 1,5 mm thick epoxy-glass printed-circuit board with a copper-thickness $\geq 40\ \mu\text{m}$, the following values apply:

1. Mounting similar to method given in Fig. 2: $R_{th\ tp-a} = 70\ \text{°C/W}$.
2. Mounted on a printed-circuit board with copper laminate (per lead) of:

$$1\ \text{cm}^2\ R_{th\ tp-a} = 55\ \text{°C/W}$$

$$2,25\ \text{cm}^2\ R_{th\ tp-a} = 45\ \text{°C/W}$$

Note

Any temperature can be calculated by using the dissipation graph (Fig. 5) and the above thermal model.



CONTROLLED AVALANCHE RECTIFIER DIODES



Double-diffused glass passivated rectifier diodes in hermetically sealed axial-leaded glass envelopes, capable of absorbing reverse transients.

They are intended for rectifier applications in colour television circuits as well as general purpose applications in telephony equipment.

QUICK REFERENCE DATA

		BYW54	BYW55	BYW56	
Crest working reverse voltage	V_{RWM} max.	600	800	1000	V
Reverse avalanche breakdown voltage	$V_{(BR)R} >$	650	900	1100	V
	$V_{(BR)R} <$	1000	1300	1600	V
Average forward current	$I_{F(AV)}$ max.	2	2	2	A
Non-repetitive peak forward current	I_{FSM} max.		50		A
Non-repetitive peak reverse power dissipation	P_{RSM} max.		1		kW
Junction temperature	T_j max.		165		°C

MECHANICAL DATA

Dimensions in mm

Fig. 1 SOD-57.

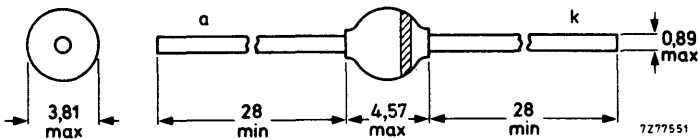

The marking band indicates the cathode.

The diodes are type-branded

Products approved to CECC 50 008-015 available on request.



RATINGS

Limiting values in accordance with the Absolute Maximum System (IEC 134)

		BYW54	BYW55	BYW56
Crest working reverse voltage	V_{RWM}	max. 600	800	1000 V
Continuous reverse voltage *	V_R	max. 600	800	1000 V
Average forward current (averaged over any 20 ms period); $T_{lead} = 25\text{ }^\circ\text{C}$; $R_{th\ j-tp} = 50\text{ }^\circ\text{C/W}$ (mounting method 1) $T_{amb} = 75\text{ }^\circ\text{C}$; $R_{th\ j-a} = 100\text{ }^\circ\text{C/W}$ (mounting method 3)				
	$I_F(AV)$	max.	2	A
	$I_F(AV)$	max.	0,8	A
Repetitive peak forward current	I_{FRM}	max.	12	A
Non-repetitive peak forward current ** ($t = 10\text{ ms}$; half sine-wave) $T_j = T_{j\ max}$ prior to surge; $V_R = 0$	I_{FSM}	max.	50	A
Non-repetitive peak reverse power dissipation ($t = 20\text{ }\mu\text{s}$; half sine-wave); $T_j = T_{j\ max}$ prior to surge	P_{RSM}	max.	1	kW
Non-repetitive peak reverse avalanche mode pulse energy; $I_R = 1\text{ A}$; $T_j = T_{j\ max}$ prior to surge; with inductive load switched off	E_{RSM}	max.	20	mJ
Storage temperature	T_{stg}		-65 to +175	$^\circ\text{C}$
Junction temperature *	T_j	max.	165	$^\circ\text{C}$

Notes

* See also Fig. 12.

** The device is capable of withstanding inrush currents when a 200 μF capacitor is connected to a 220 V mains with a series resistance of 2,4 Ω .

THERMAL RESISTANCE

Influence of mounting method

1. Thermal resistance from junction to tie-point at a lead length $a = 10$ mm; Fig. 2
2. Thermal resistance from junction to ambient when mounted to solder tags at a lead length $a = 10$ mm; Fig. 3
3. Thermal resistance from junction to ambient when mounted on a 1,5 mm thick epoxy-glass printed-circuit board; Cu-thickness ≥ 40 μ m; Fig. 4

$$R_{th\ j-tp} = 46\ \text{°C/W}$$

$$R_{th\ j-a} = 80\ \text{°C/W}$$

$$R_{th\ j-a} = 100\ \text{°C/W}$$

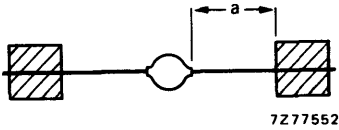

Fig. 2 Mounting method 1.

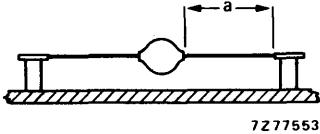

Fig. 3 Mounting method 2.

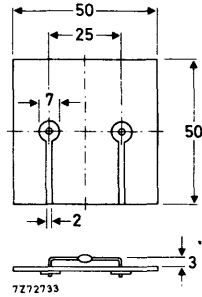

Fig. 4 Mounting method 3.

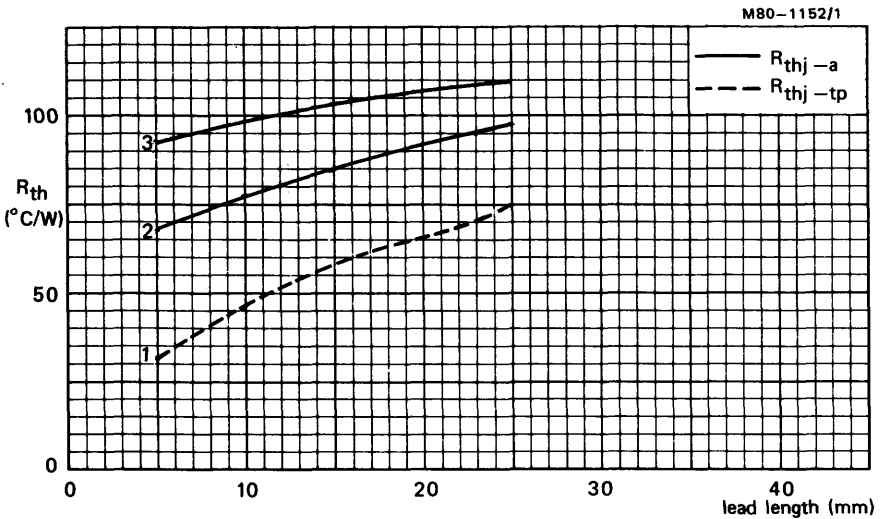

Fig. 5 Thermal resistance as a function of lead length for mounting methods 1, 2 and 3.

CHARACTERISTICS

Forward voltage; $T_j = 25\text{ }^\circ\text{C}^*$

$I_F = 1\text{ A}$
 $I_F = 10\text{ A}$

$V_F <$
 $V_F <$

BYW54	BYW55	BYW56
1	1	1 V
1,65	1,65	1,65 V
650	900	1100 V
1000	1300	1600 V

Reverse avalanche breakdown voltage

$I_R = 0,1\text{ mA}; T_j = 25\text{ }^\circ\text{C}$

$V_{(BR)R} >$
 $V_{(BR)R} <$

Reverse current

$V_R = V_{RWM\text{ max}}; T_j = 25\text{ }^\circ\text{C}^{**}$
 $V_R = V_{RWM\text{ max}}; T_j = 100\text{ }^\circ\text{C}$

$I_R <$
 $I_R <$

1,0 μA
 10 μA

Reverse recovery charge when switched

from $I_F = 1\text{ A}$ to $V_R \geq 50\text{ V}$ with
 $-dI_F/dt = 5\text{ A}/\mu\text{s}; T_j = 25\text{ }^\circ\text{C}$

Q_S typ.

3 μC

Reverse recovery time when switched

from $I_F = 1\text{ A}$ to $V_R \geq 50\text{ V}$ at $i_{rr} = 10\%$
 of I_R with $-dI_F/dt = 5\text{ A}/\mu\text{s}; T_j = 25\text{ }^\circ\text{C}$

t_{rr} typ.

2,5 μs

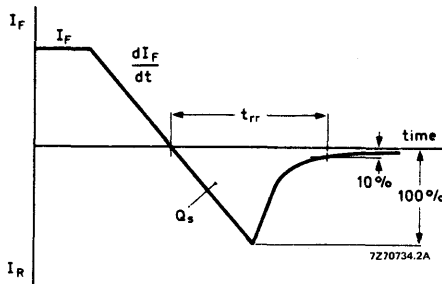

Fig. 6 Definitions of t_{rr} and Q_S .

Diode capacitance

$V_R = 0\text{ V}; f = 1\text{ MHz}; T_j = 25\text{ }^\circ\text{C}$

C_d typ.

50 pF

* Measured under pulse conditions to avoid excessive dissipation.

** Illuminance $< 500\text{ lux}$ (daylight); relative humidity $< 65\%$.

7277556

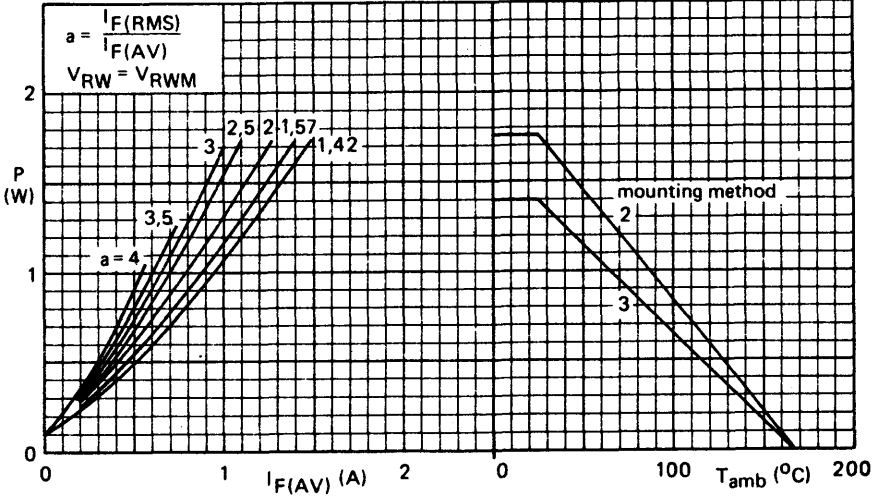

Fig. 7 Interrelation between the steady-state power dissipation excluding power in avalanche region (left-hand graph), and the maximum permissible ambient temperature (no leads of other dissipating components running to the same tie-points) in accordance with the mounting methods mentioned in Figs 3 and 4.

7277554

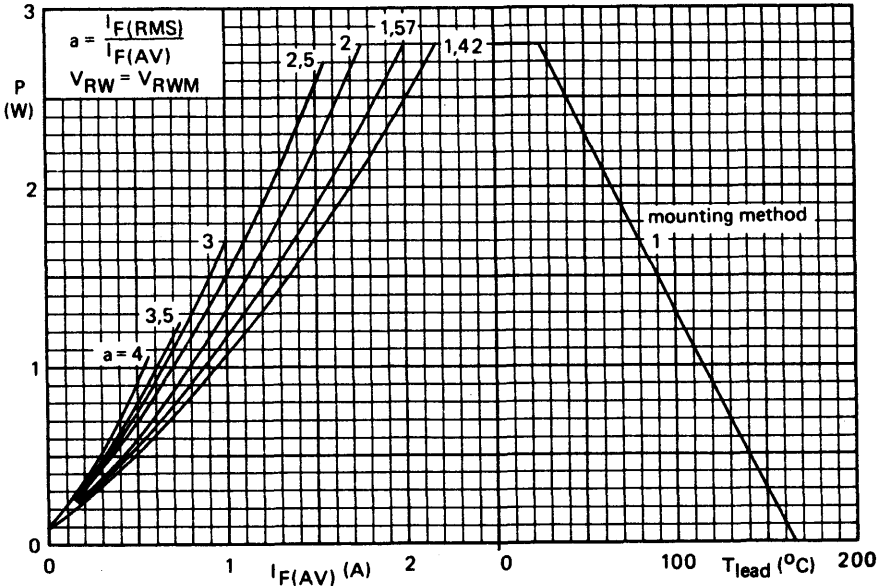

Fig. 8 Interrelation between the steady-state power dissipation excluding power in avalanche region (left-hand graph) and the maximum permissible lead temperature.

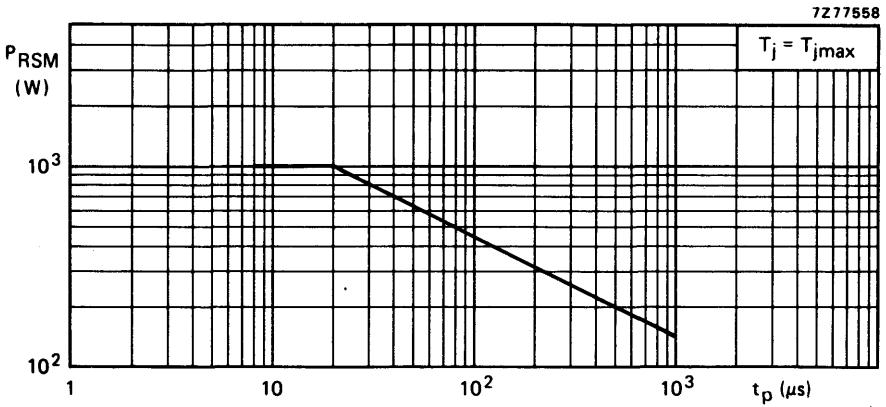

Fig. 9 Maximum permissible non-repetitive peak reverse power dissipation in the avalanche region.

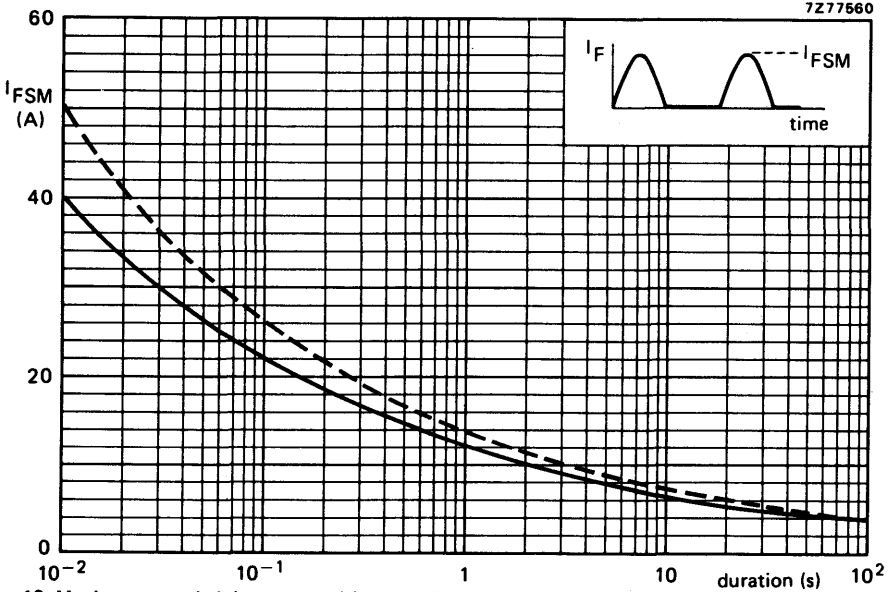
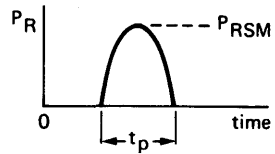

Fig. 10 Maximum permissible non-repetitive peak forward current based on sinusoidal currents ($f = 50 \text{ Hz}$)

- $T_j = T_{j \text{ max}}$ prior to surge; $V_R = 0$
- $T_j = 25 \text{ }^\circ\text{C}$; $V_R = V_{RWM \text{ max}}$

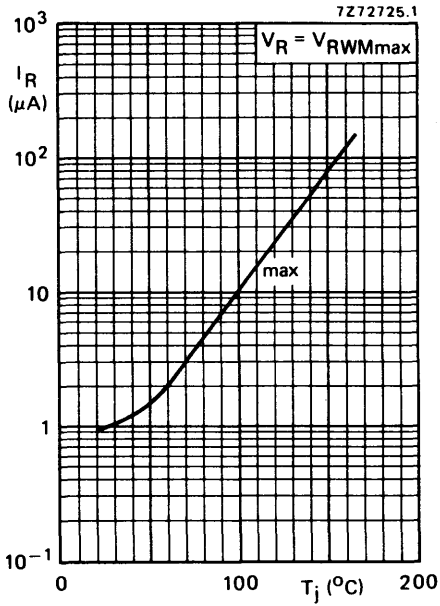

Fig. 11.

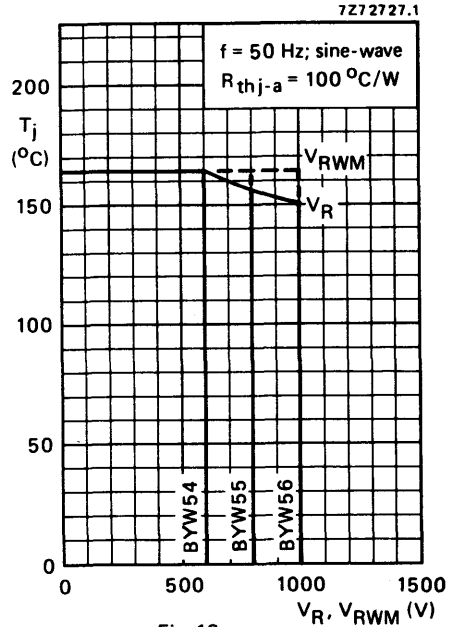

Fig. 12.

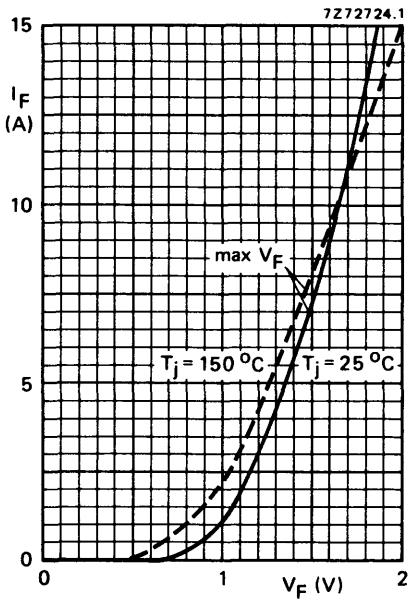

Fig. 13.

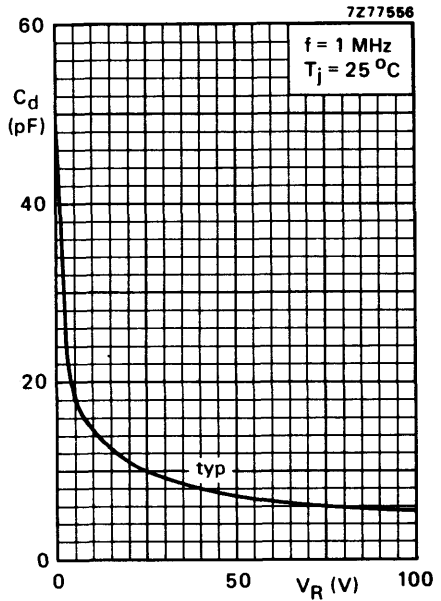

Fig. 14.

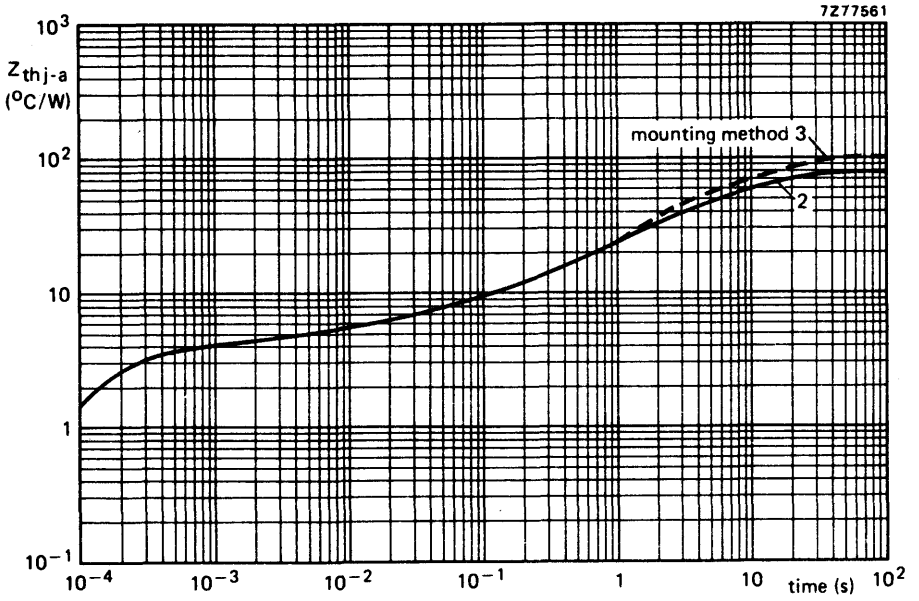

Fig. 15.

OPERATING NOTES

The various components of junction temperature rise above ambient, for mounting with symmetrical lead length, are illustrated below.

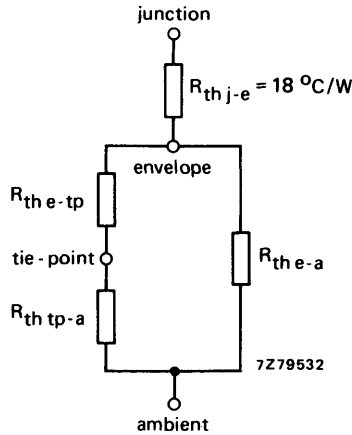

Fig. 16

The thermal resistances between envelope and tie-point, and between envelope and ambient depend on lead length.

lead length	5	10	15	20	25	mm
$R_{th\ e-tp}$	15	30	45	60	75	°C/W
$R_{th\ e-a}$	580	445	350	290	245	°C/W

The thermal resistance between tie-point and ambient depends on the mounting method; for mounting on a 1,5 mm thick epoxy-glass printed-circuit board with a copper-thickness $\geq 40\ \mu\text{m}$, the following values apply:

1. Mounting similar to method given in Fig. 4: $R_{th\ tp-a} = 70\ \text{°C/W}$.
2. Mounted on a printed-circuit board with copper laminate (per lead) of:

$$1\ \text{cm}^2\ R_{th\ tp-a} = 55\ \text{°C/W}$$

$$2,25\ \text{cm}^2\ R_{th\ tp-a} = 45\ \text{°C/W}$$

Note

Any temperature can be calculated by using the dissipation graph (Figs. 7 and 8) and the above thermal model.

AVALANCHE FAST SOFT-RECOVERY RECTIFIER DIODES

Glass passivated rectifier diodes in hermetically sealed axial-leaded glass envelopes. They are intended for television and industrial applications, such as switched-mode power supplies, scan rectifiers, in TV receivers, and also for use in inverter and converter applications. The devices feature non-snap-off (soft-recovery) switching characteristics and are capable of absorbing reverse transient energy (e.g. during flashover in the picture tube).

QUICK REFERENCE DATA

		BYW95A	B	C
Repetitive peak reverse voltage	V_{RRM} max.	200	400	600 V
Continuous reverse voltage	V_R max.	200	400	600 V
Average forward current	$I_F(AV)$ max.	3		A
Non-repetitive peak forward current	I_{FSM} max.	70		A
Non-repetitive peak reverse energy	E_{RSM} max.	10		mJ
Reverse recovery time	t_{rr} <	250		ns

MECHANICAL DATA

Dimensions in mm

Fig. 1 SOD-64.

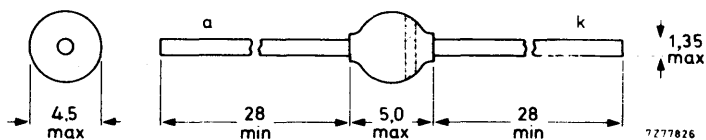

The marking band indicates the cathode.

The diodes are type-branded



RATINGS

Limiting values in accordance with the Absolute Maximum System (IEC 134)

		BYW95A	B	C
Repetitive peak reverse voltage	V_{RRM} max.	200	400	600 V
Continuous reverse voltage	V_R max.	200	400	600 V
Average forward current (averaged over any 20 ms period)				
$T_{tp} = 50\text{ }^\circ\text{C}$; lead length 10 mm	$I_{F(AV)}$ max.		3	A
$T_{amb} = 55\text{ }^\circ\text{C}$; Fig. 2	$I_{F(AV)}$ max.		1,25	A
Repetitive peak forward current	I_{FRM} max.		15	A
Non-repetitive peak forward current ($t = 10\text{ ms}$; half sine-wave) $T_j = T_{j\text{ max}}$ prior to surge; $V_R = V_{RRM\text{ max}}$	I_{FSM} max.		70	A
Non-repetitive peak reverse avalanche energy; $I_R = 400\text{ mA}$; $T_j = T_{j\text{ max}}$ prior to surge; with inductive load switched off	E_{RSM} max.		10	mJ
Storage temperature	T_{stg}	-65 to + 175		$^\circ\text{C}$
Operating junction temperature	T_j max.	165		$^\circ\text{C}$

THERMAL RESISTANCE

Influence of mounting method

1. Thermal resistance from junction to tie-point at a lead length of 10 mm
 $R_{th\ j-tp} = 25\text{ }^\circ\text{C/W}$
2. Thermal resistance from junction to ambient when mounted on a 1,5 mm thick epoxy-glass printed-circuit board; Cu-thickness $\geq 40\text{ }\mu\text{m}$; Fig. 2
 $R_{th\ j-a} = 75\text{ }^\circ\text{C/W}$

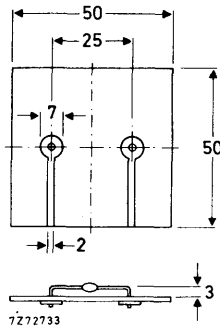

Fig. 2 Mounted on a printed-circuit board.



CHARACTERISTICS

$T_j = 25\text{ }^\circ\text{C}$ unless otherwise specified

Forward voltage

$I_F = 5\text{ A}$

$I_F = 5\text{ A}; T_j = 165\text{ }^\circ\text{C}$

Reverse avalanche breakdown voltage

$I_R = 0,1\text{ mA}$

Reverse current

$V_R = V_{RRMmax}; T_j = 165\text{ }^\circ\text{C}$

Reverse recovery when switched from

$I_F = 1\text{ A}$ to $V_R \geq 30\text{ V}$ with

$-dI_F/dt = 20\text{ A}/\mu\text{s}$

recovered charge

recovery time

Maximum slope of reverse recovery current when switched from $I_F = 1\text{ A}$ to $V_R \geq 30\text{ V}$ with $-dI_F/dt = 1\text{ A}/\mu\text{s}$

	BYW95A	B	C
$V_F <$	1,5	1,5	1,5 V *
$V_F <$	1,25	1,25	1,25 V *
$V_{(BR)R} >$	300	500	700 V
$I_R <$		150	μA
$Q_s <$		250	nC
$t_{rr} <$		250	ns
$ dI_R/dt <$		6	$\text{A}/\mu\text{s}$

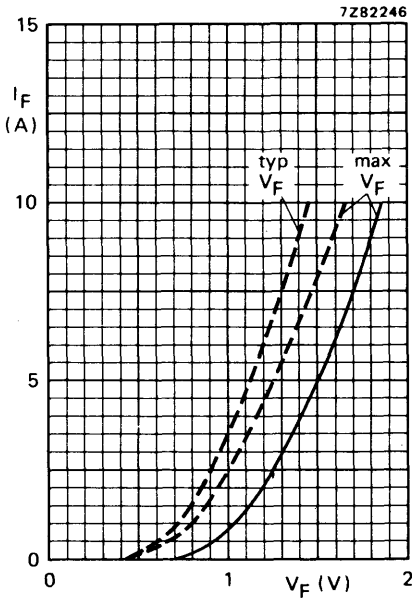

Fig. 3 — $T_j = 25\text{ }^\circ\text{C}$; --- $T_j = 165\text{ }^\circ\text{C}$.

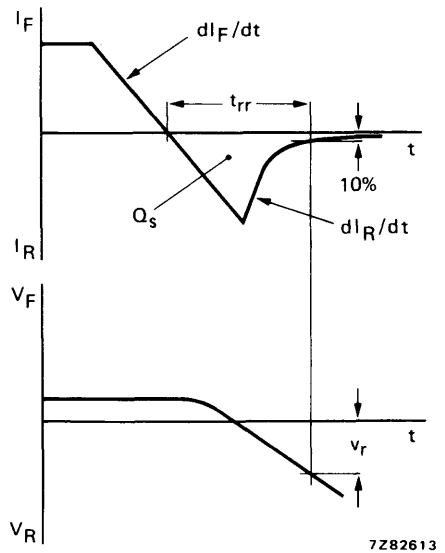

Fig. 4 Definitions.

* Measured under pulse conditions to avoid excessive dissipation.



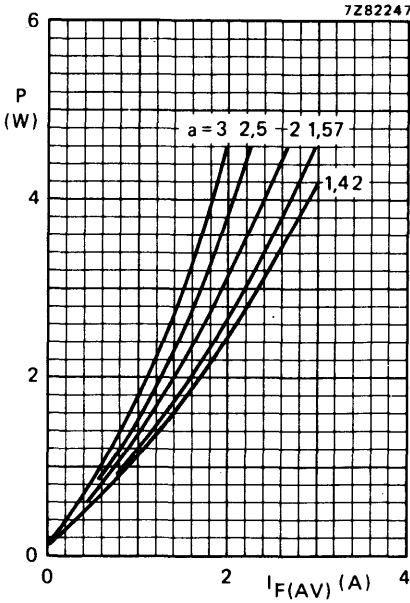

Fig. 5 Steady state power dissipation (forward plus leakage current) excluding switching losses as a function of the average forward current.

The graph is for switched-mode application.

$a = I_{F(RMS)}/I_{F(AV)}; V_R = V_{RRMmax}$

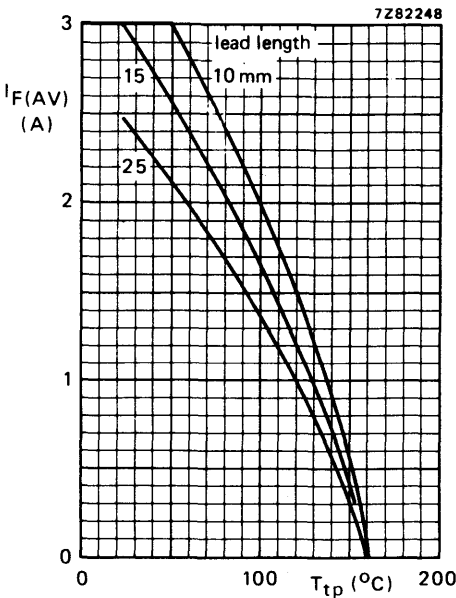
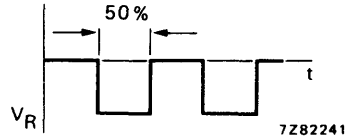

Fig. 6 Maximum average forward current as a function of the tie-point temperature; the curves include losses due to reverse leakage.

The graph is for switched-mode application;

$V_R = V_{RRMmax}; \delta = 50\%; a = 1,57.$



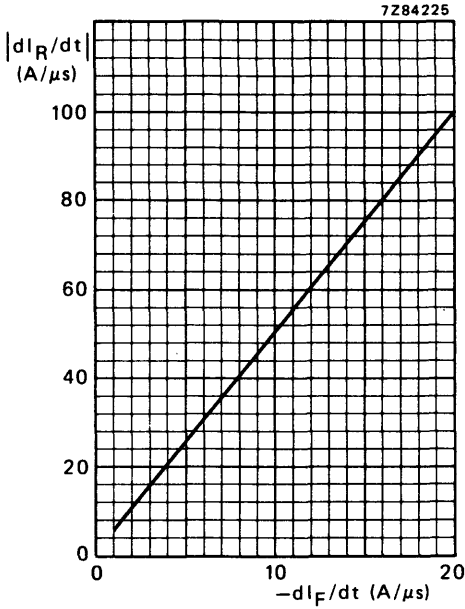

Fig. 7 Maximum slope of reverse recovery current. $T_j = 25^\circ\text{C}$.

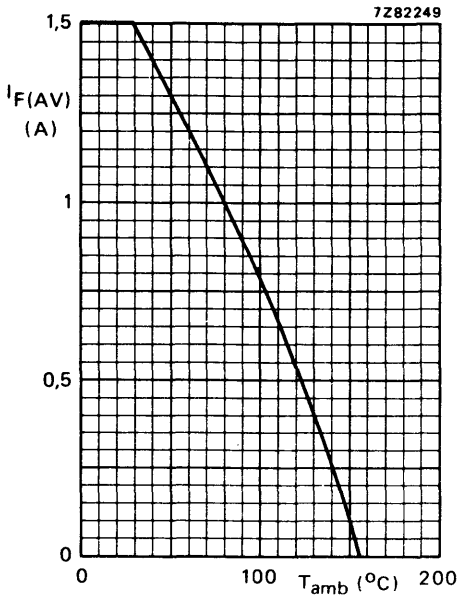

Fig. 8 Maximum average forward current as a function of the ambient temperature; the curve includes losses due to reverse leakage. Mounting method see Fig. 2.

The graph is for switched-mode application; $V_R = V_{RRMmax}$; $\delta = 50\%$; $a = 1,57$.



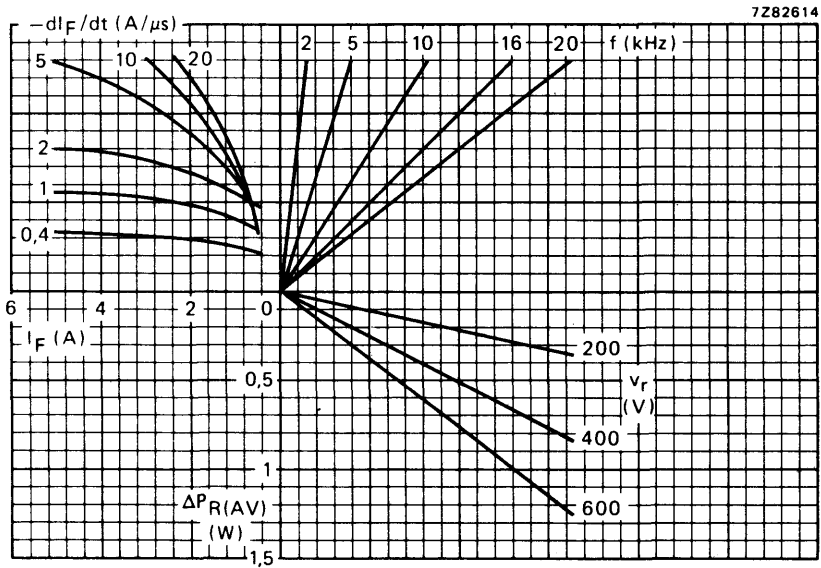

Fig. 9 Nomogram: power loss (ΔP_R (AV)) due to switching only. To be added to steady state power losses (see also Fig. 4).

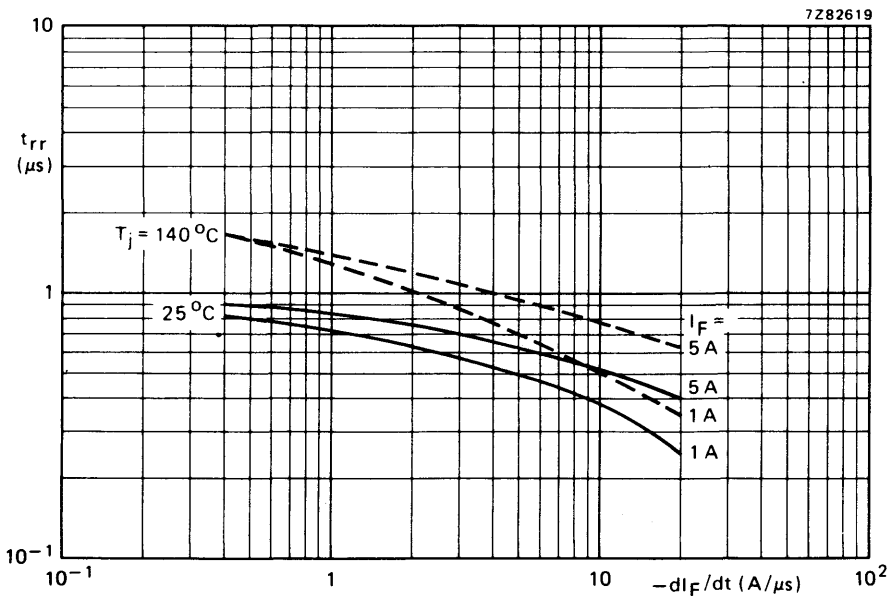

Fig. 10 Maximum values; for definitions see Fig. 4.



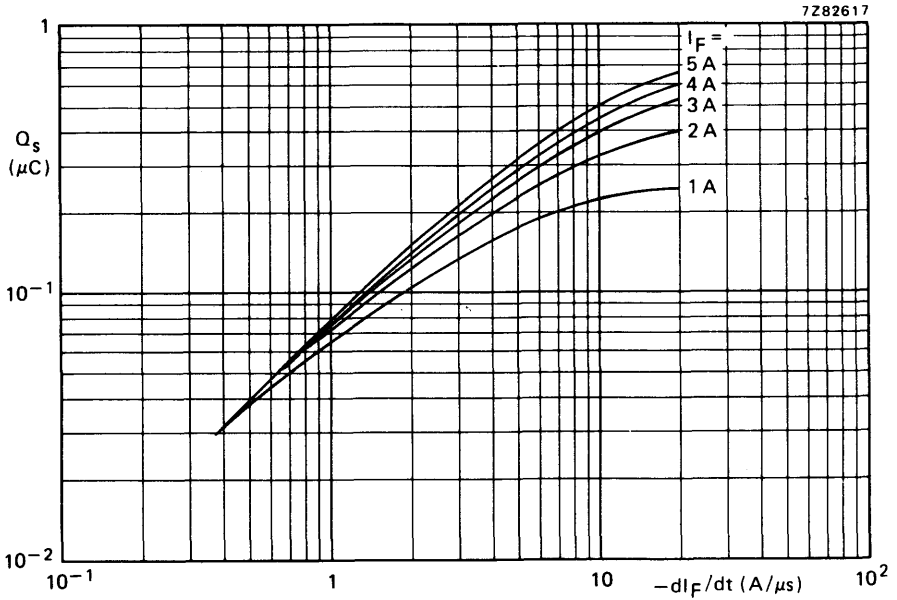

Fig. 11 Maximum values; $T_j = 25^\circ\text{C}$. For definitions see Fig. 4.

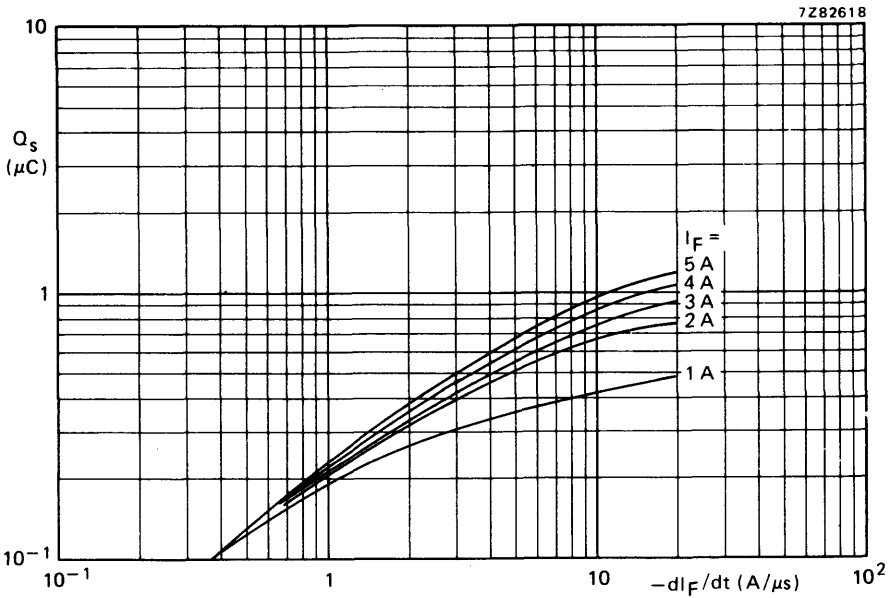

Fig. 12 Maximum values; $T_j = 140^\circ\text{C}$. For definitions see Fig. 4.



OPERATING NOTES

The various components of junction temperature rise above ambient, for mounting with symmetrical lead length, are illustrated below.

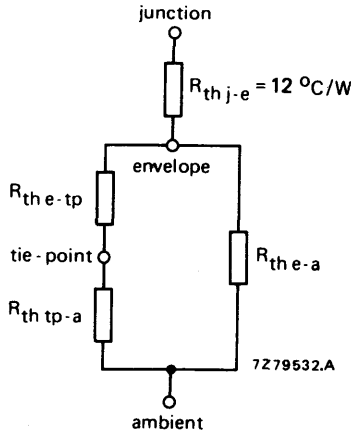

Fig. 13.

The thermal resistances between envelope and tie-point, and between envelope and ambient depend on lead length.

lead length	5	10	15	20	25	mm
$R_{th\ e-tp}$	7	14	21	28	35	°C/W
$R_{th\ e-a}$	410	300	230	185	155	°C/W

The thermal resistance between tie-point and ambient depends on the mounting method; for mounting on a 1,5 mm thick epoxy-glass printed-circuit board with a copper-thickness $\geq 40\ \mu\text{m}$, the following values apply:

1. Mounting similar to method given in Fig. 2: $R_{th\ tp-a} = 70\ \text{°C/W}$.
2. Mounted on a printed-circuit board with a copper laminate (per lead) of:
 - 1 cm² $R_{th\ tp-a} = 55\ \text{°C/W}$
 - 2,25 cm² $R_{th\ tp-a} = 45\ \text{°C/W}$

Note

Any temperature can be calculated by using the dissipation graph (Fig. 5) and the above thermal model.



AVALANCHE FAST SOFT-RECOVERY RECTIFIER DIODES

Glass passivated rectifier diodes in hermetically sealed axial-leaded glass envelopes. They are intended for television and industrial applications, such as switched-mode power supplies, scan rectifiers, in TV receivers, and also for use in inverter and converter applications. The devices feature non-snap-off (soft-recovery) switching characteristics and are capable of absorbing reverse transient energy (e.g. during flashover in the picture tube).

QUICK REFERENCE DATA

			BYW96D	BYW96E	
Repetitive peak reverse voltage	V_{RRM}	max.	800	1000	V
Continuous reverse voltage	V_R	max.	800	1000	V
Average forward current	$I_F(AV)$	max.		3	A
Non-repetitive peak forward current	I_{FSM}	max.		70	A
Non-repetitive peak reverse energy	E_{RSM}	max.		10	mJ
Reverse recovery time	t_{rr}	<		300	ns

MECHANICAL DATA

Dimensions in mm

Fig. 1 SOD-64.

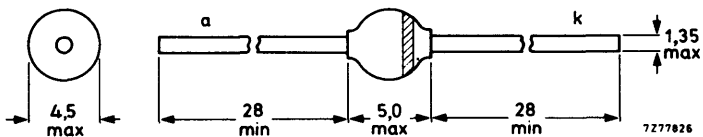

The marking band indicates the cathode.

The diodes are type-branded



RATINGS

Limiting values in accordance with the Absolute Maximum System (IEC 134)

			BYW96D	BYW96E	
Repetitive peak reverse voltage	V_{RRM}	max.	800	1000	V
Continuous reverse voltage	V_R	max.	800	1000	V
Average forward current (averaged over any 20 ms period) $T_{tp} = 50\text{ }^\circ\text{C}$; lead length 10 mm $T_{amb} = 55\text{ }^\circ\text{C}$; Fig. 2	$I_F(AV)$	max.	3		A
	$I_F(AV)$	max.	1,25		A
Repetitive peak forward current	I_{FRM}	max.	15		A
Non-repetitive peak forward current ($t = 10\text{ ms}$; half sine-wave) $T_j = T_{j\text{ max}}$ prior to surge; $V_R = V_{RRM\text{ max}}$	I_{FSM}	max.	70		A
Non-repetitive peak reverse avalanche energy; $I_R = 400\text{ mA}$; $T_j = T_{j\text{ max}}$ prior to surge; with inductive load switched off	E_{RSM}	max.	10		mJ
Storage temperature	T_{stg}		-65 to +175		$^\circ\text{C}$
Operating junction temperature	T_j	max.	165		$^\circ\text{C}$

THERMAL RESISTANCE

Influence of mounting method

1. Thermal resistance from junction to tie-point at a lead length of 10 mm
2. Thermal resistance from junction to ambient when mounted on a 1,5 mm thick epoxy-glass printed-circuit board; Cu-thickness $\geq 40\text{ }\mu\text{m}$; Fig. 2

$R_{th\ j\text{-tp}} = 25\text{ }^\circ\text{C/W}$

$R_{th\ j\text{-a}} = 75\text{ }^\circ\text{C/W}$

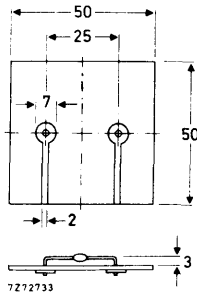

Fig. 2 Mounted on a printed-circuit board.



CHARACTERISTICS

$T_j = 25\text{ }^\circ\text{C}$ unless otherwise specified

Forward voltage

$I_F = 5\text{ A}$

$I_F = 5\text{ A}; T_j = 165\text{ }^\circ\text{C}$

Reverse avalanche breakdown voltage

$I_R = 0,1\text{ mA}$

Reverse current

$V_R = V_{RRMmax}; T_j = 165\text{ }^\circ\text{C}$

Reverse recovery when switched from

$I_F = 1\text{ A}$ to $V_R \geq 30\text{ V}$ with

$-dI_F/dt = 20\text{ A}/\mu\text{s}$

recovered charge

recovery time

Maximum slope of reverse recovery current

when switched from $I_F = 1\text{ A}$ to $V_R \geq 30\text{ V}$

with $-dI_F/dt = 1\text{ A}/\mu\text{s}$

	BYW96D	BYW96E	
--	--------	--------	--

V_F	<	1,5	1,5	V^*
V_F	<	1,25	1,25	V^*
$V_{(BR)R}$	>	900	1100	V
I_R	<	150		μA
Q_s	<	400		nC
t_{rr}	<	300		ns
$ dI_R/dt $	<	5		$\text{A}/\mu\text{s}$

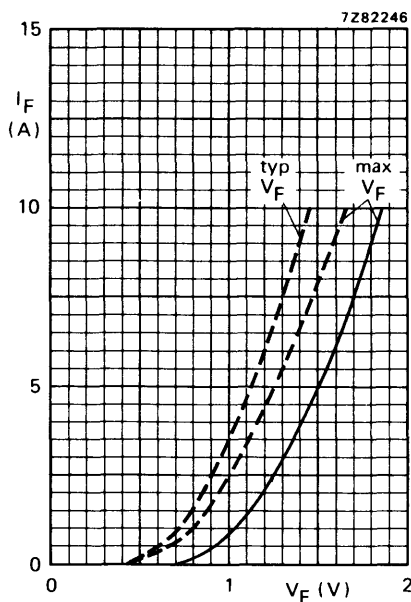

Fig. 3 — $T_j = 25\text{ }^\circ\text{C}$; - - - $T_j = 165\text{ }^\circ\text{C}$.

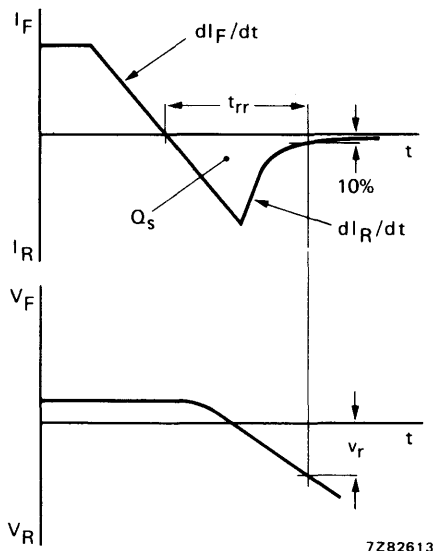

Fig. 4 Definitions.

* Measured under pulse conditions to avoid excessive dissipation.



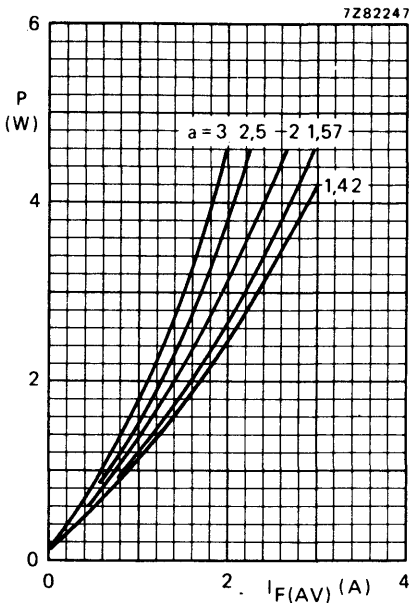

Fig. 5.

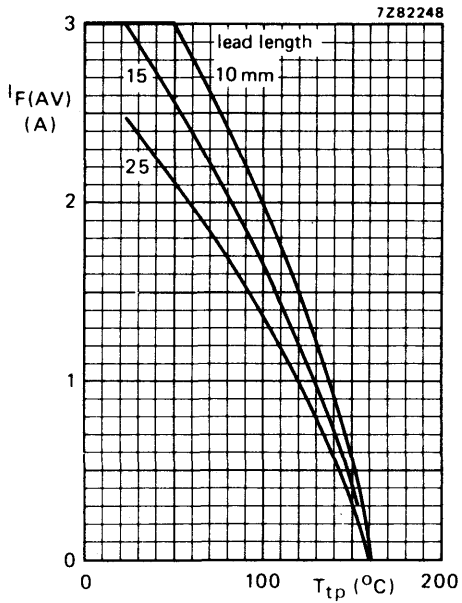

Fig. 6.

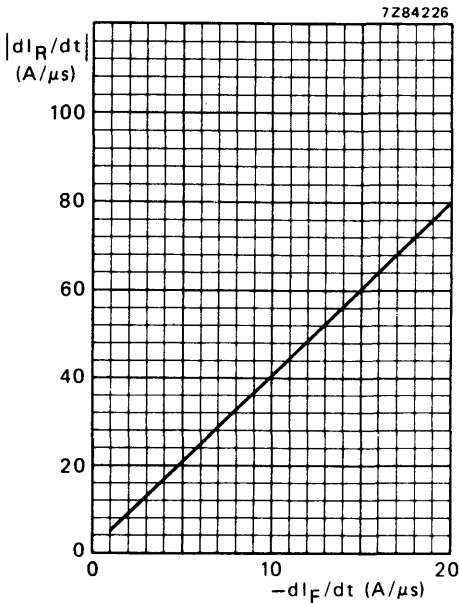

Fig. 7.

Fig. 5 Steady state power dissipation (forward plus leakage current) excluding switching losses as a function of the average forward current. The graph is for switched-mode application.

The graph is for switched-mode application.

$$a = I_F(\text{RMS})/I_F(\text{AV}); V_R = V_{\text{RRMmax}}$$

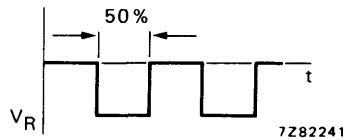

Fig. 6 Maximum average forward current as a function of the tie-point temperature; the curves include losses due to reverse leakage.

The graph is for switched-mode application;

$$V_R = V_{\text{RRMmax}}; \delta = 50\%; a = 1,57.$$

Fig. 7 Maximum slope of reverse recovery current. $T_j = 25^\circ\text{C}$.



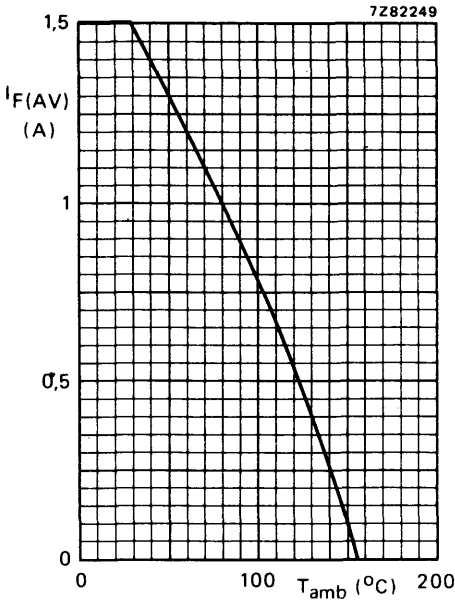

Fig. 8 Maximum average forward current as a function of the ambient temperature; the curve includes losses due to reverse leakage. Mounting method see Fig. 2.

The graph is for switched-mode application; $V_R = V_{RRMmax}$; $\delta = 50\%$; $a = 1,57$.

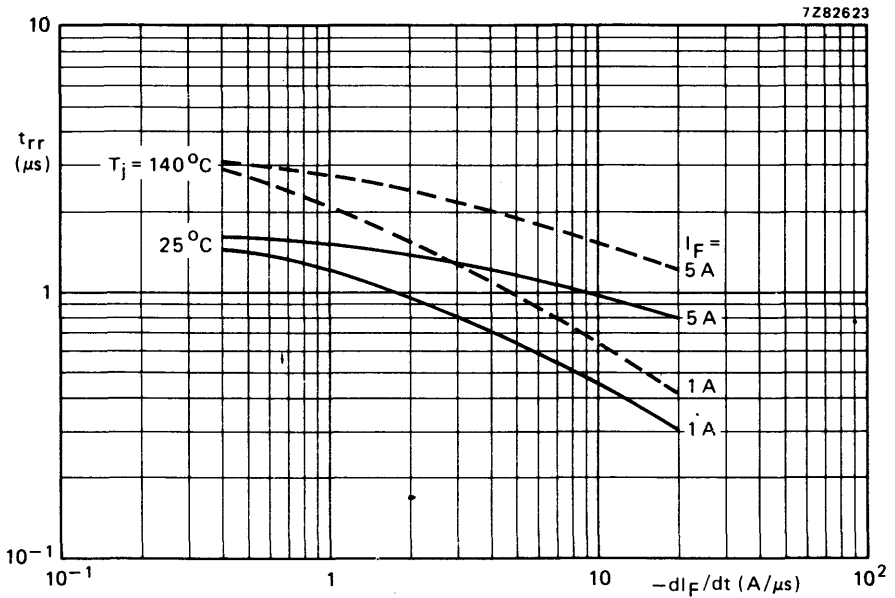

Fig. 9 Maximum values. For definitions see Fig. 4.



7Z82626

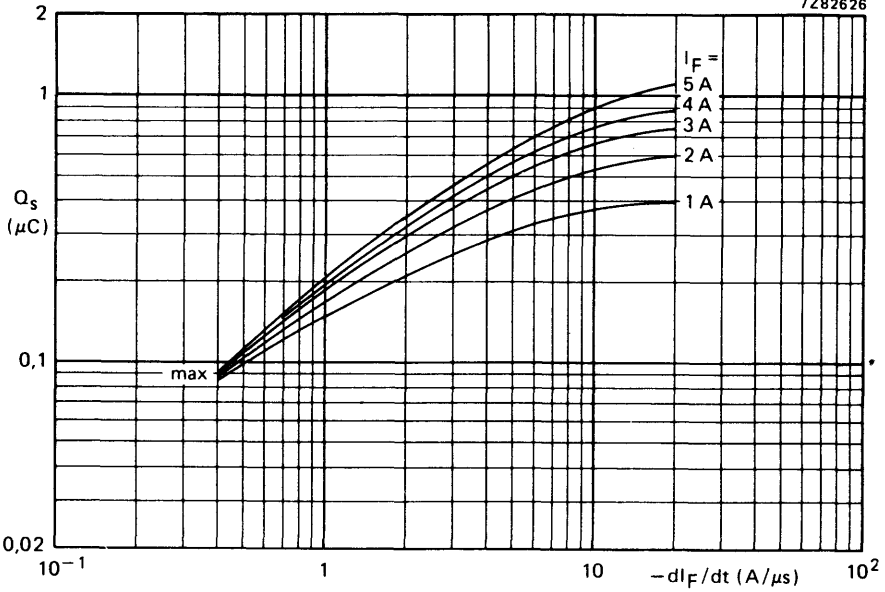

Fig. 10 Maximum values at $T_j = 25^\circ\text{C}$ (see also Fig. 4).

7Z82622

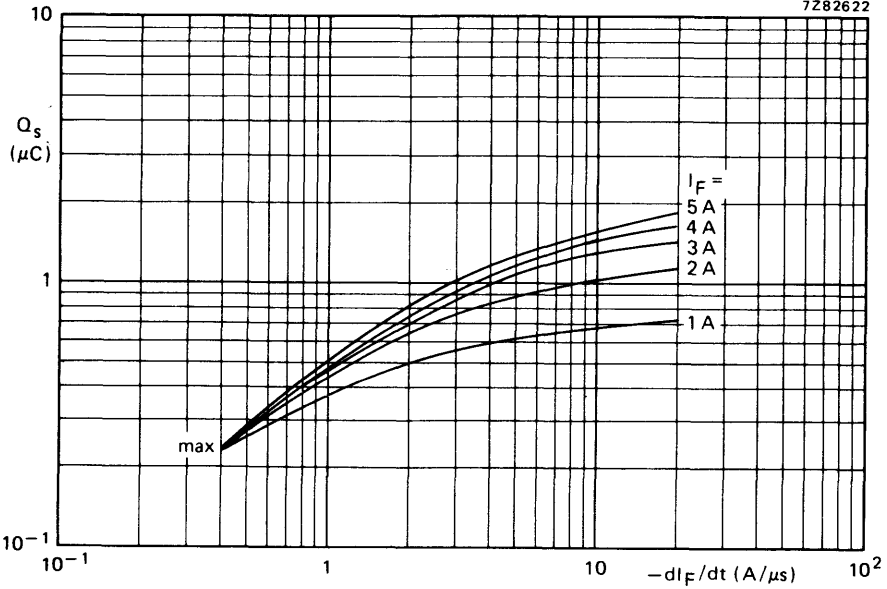

Fig. 11 Maximum values at $T_j = 140^\circ\text{C}$ (see also Fig. 4).



OPERATING NOTES

The various components of junction temperature rise above ambient, for mounting with symmetrical lead length, are illustrated below.

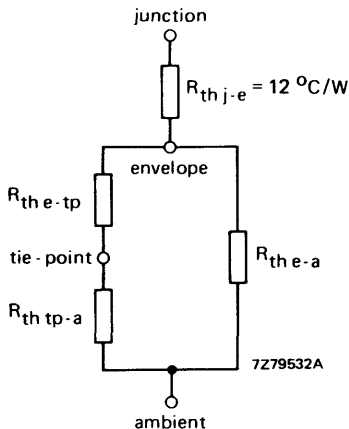

Fig. 12.

The thermal resistances between envelope and tie-point, and between envelope and ambient depend on lead length.

lead length	5	10	15	20	25	mm
$R_{th e-tp}$	7	14	21	28	35	°C/W
$R_{th e-a}$	410	300	230	185	155	°C/W

The thermal resistance between tie-point and ambient depends on the mounting method; for mounting on a 1,5 mm thick epoxy-glass printed-circuit board with a copper-thickness $\geq 40 \mu\text{m}$, the following values apply:

1. Mounting similar to method given in Fig. 2: $R_{th tp-a} = 70 \text{ °C/W}$.
2. Mounted on a printed-circuit board with a copper laminate (per lead) of:
 - 1 cm² $R_{th tp-a} = 55 \text{ °C/W}$
 - 2,25 cm² $R_{th tp-a} = 45 \text{ °C/W}$

Note

Any temperature can be calculated by using the dissipation graph (Fig. 5) and the above thermal model.



SILICON RECTIFIER DIODE

Double-diffused silicon diode in a DO-14 plastic envelope.
It is intended for low current rectifier applications.

QUICK REFERENCE DATA			
Repetitive peak reverse voltage	V_{RRM}	max.	1600 V
Average forward current	$I_{F(AV)}$	max.	0,5 A
Non-repetitive peak forward current	I_{FSM}	max.	15 A

MECHANICAL DATA

Dimensions in mm

DO-14 The diodes are type-branded

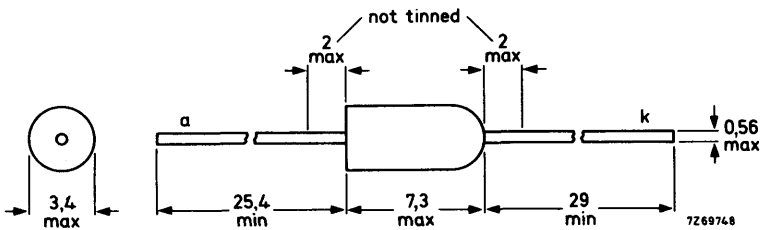

The rounded end indicates the cathode

The sealing of the plastic envelope withstands the accelerated damp heat test of IEC recommendation 68-2 (test D, severity IV, 6 cycles).

MOUNTING METHODS see page 3.



All information applies to frequencies up to 400 Hz.

RATINGS Limiting values in accordance with the Absolute Maximum System (IEC 134)

Voltages

Crest working reverse voltage	V_{RWM}	max.	800 V
Repetitive peak reverse voltage ($\delta \leq 0.01$)	V_{RRM}	max.	1600 V
Non-repetitive peak reverse voltage ($t < 10$ ms)	V_{RSM}	max.	1600 V

Currents

Average forward current (averaged over any 20 ms period)

with R load;	$V_{RWM} = V_{RWMmax}$	$I_{F(AV)}$	max.	0.36 A
	$V_{RWM} = 60$ V	$I_{F(AV)}$	max.	0.5 A
for capacitive load				see page 4

Repetitive peak forward current	I_{FRM}	max.	3 A
---------------------------------	-----------	------	-----

Non-repetitive peak forward current ($t = 10$ ms; half-sine wave) $T_j = 150$ °C prior to surge	I_{FSM}	max.	15 A
---	-----------	------	------

Temperatures

Storage temperature	T_{stg}	-65 to +150	°C
Junction temperature	T_j	max.	150 °C

THERMAL RESISTANCE

See page 3

CHARACTERISTICS

Forward voltage

$I_F = 2$ A; $T_j = 25$ °C	V_F	<	1.6 V 1)
----------------------------	-------	---	----------

Reverse current

$V_R = 800$ V; $T_j = 125$ °C	I_R	<	50 μ A
$V_R = 800$ V; $T_j = 25$ °C	I_R	<	1 μ A

1) Measured under pulse conditions to avoid excessive dissipation.

THERMAL RESISTANCE (influence of mounting method)

The quoted values apply when no other leads run to the tie-points. If leads of other dissipating components share the same tie-points, the thermal resistance will be higher than that quoted.

1. Mounted to solder tags at a
lead-length $a = 10$ mm. $R_{th\ j-a} = 150$ °C/W
2. Mounted to solder tags at $a =$ maximum
lead-length. $R_{th\ j-a} = 200$ °C/W
3. Mounted on printed-wiring with a small
area of copper at any lead-length a .
 $R_{th\ j-a} = 200$ °C/W

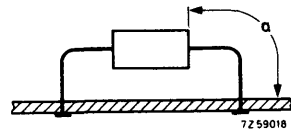
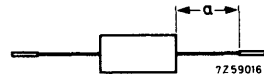
**SOLDERING AND MOUNTING NOTES**

1. Soldered joints must be at least 5 mm from the seal.
2. The maximum permissible temperature of the soldering iron or bath is 300 °C; it must be in contact with the joint for no more than 3 seconds.
3. Avoid hot spots due to handling or mounting; the body of the device must not come into contact with or be exposed to a temperature higher than 150 °C.

EXAMPLE: Rectifier with C-load mounting method 1 (see page 3)

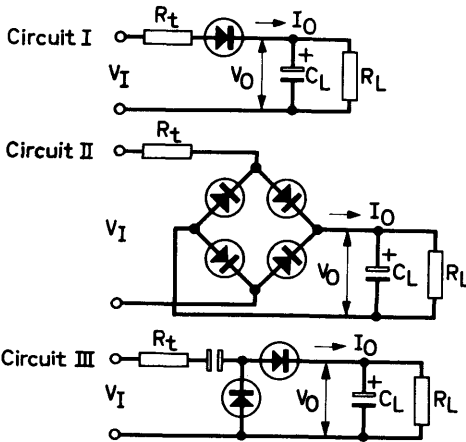
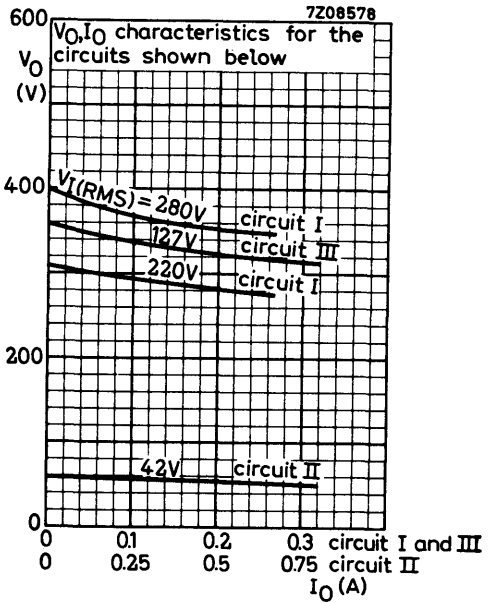
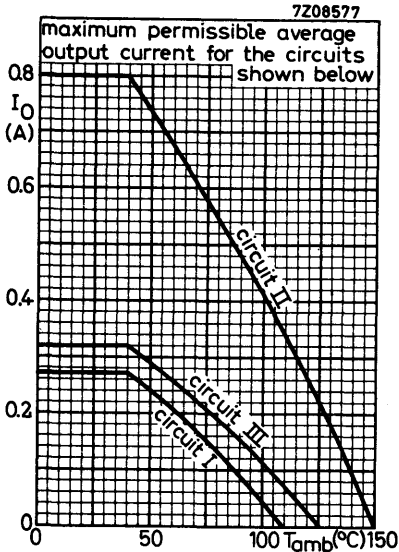

	V_I (RMS)	R_t	C_L
Circuit I	220V	8.2Ω	$100 \mu F$
	280V	15Ω	$100 \mu F$
Circuit II	42V	1.5Ω	$1500 \mu F$
Circuit III	127V	5.6Ω	$200 \mu F$

7208584

7272501

mounting method 1 (see page 3)
max. permissible average forward
current versus ambient temperature

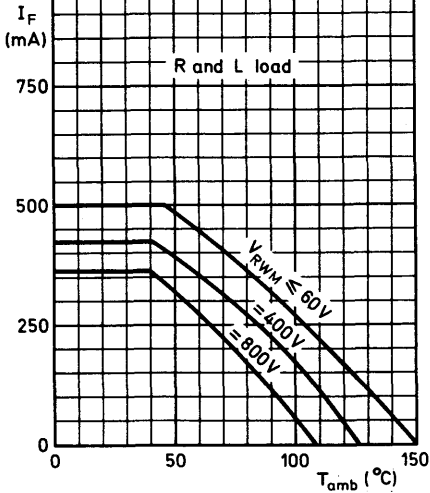

7272502

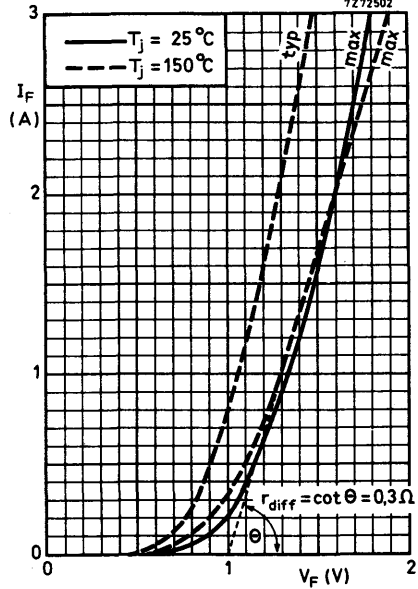

7272500

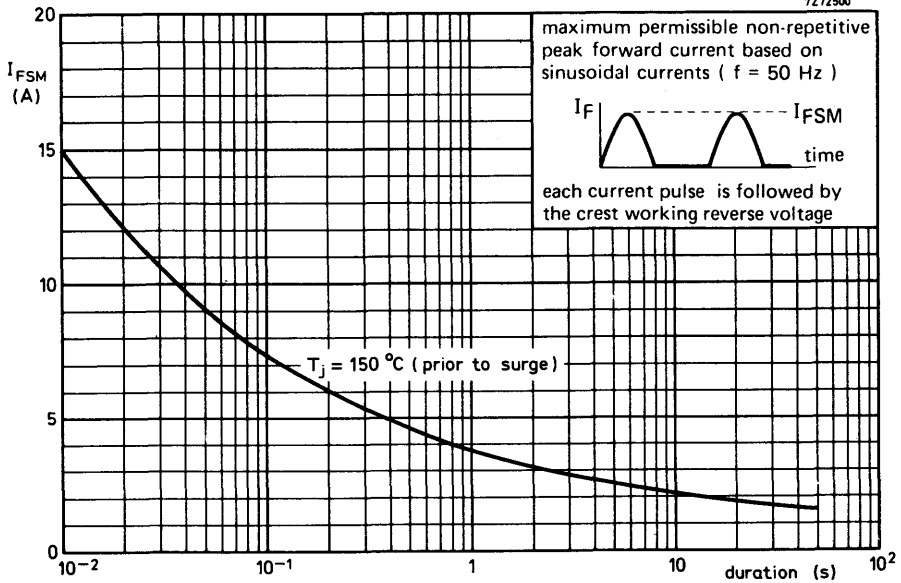

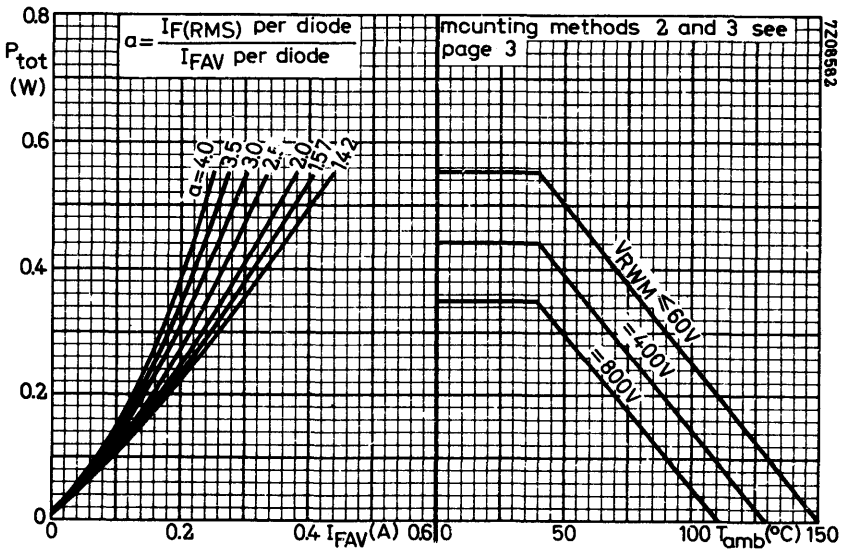
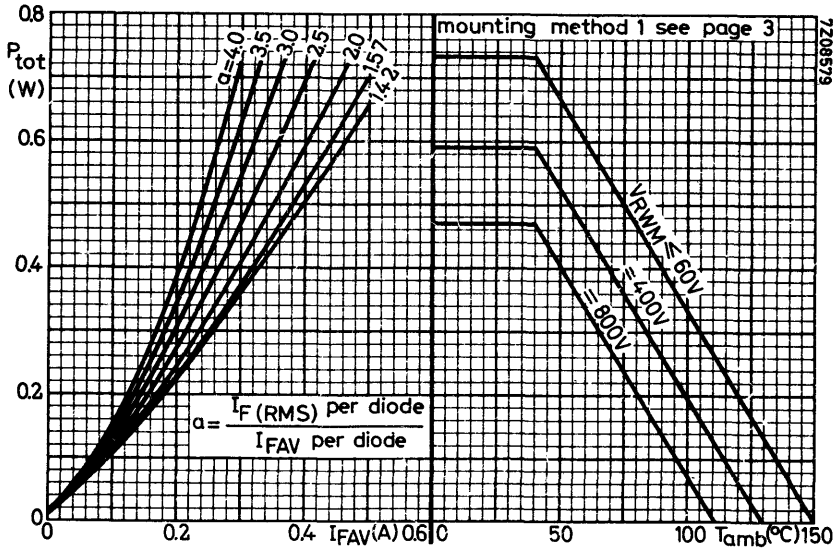

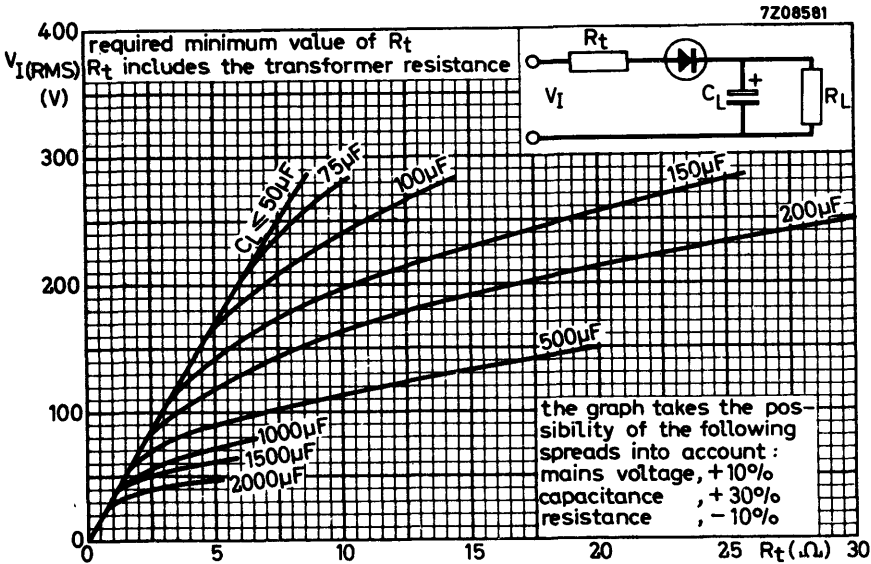

From the left hand graph on page 6 the total power dissipation can be found as a function of the average output current.

The parameter $a = \frac{I_F(\text{RMS}) \text{ per diode}}{I_{\text{FAV}} \text{ per diode}}$ depends on $n\omega R_L C_L$ and $\frac{R_t + R_{\text{diff}}}{nR_L}$ and can be found from existing graphs.

See Application Book: RECTIFIER DIODES

Once the power dissipation is known, the max. permissible ambient temperature follows from the right hand graph.

For the series resistance, added to limit the initial peak rectifier current, the required minimum value can be found from the upper graph.

R_{diff} is shown on page 5 upper figure.

SILICON RECTIFIER DIODES

Diffused silicon rectifier diodes in DO-15 plastic envelopes for general purposes. The series consists of the following types: BYX36-150, BYX36-300, BYX36-600.

		QUICK REFERENCE DATA			
		BYX36-150	300	600	
Crest working reverse voltage	V_{RWM}	max. 100	200	400	V
Repetitive peak reverse voltage	V_{RRM}	max. 150	300	600	V
Average forward current with R load up to $T_{amb} = 45\text{ }^{\circ}\text{C}$	$I_{F(AV)}$	max.	1,0		A
Non-repetitive peak forward current $t = 10\text{ ms}$; $T_j = 125\text{ }^{\circ}\text{C}$ prior to surge	I_{FSM}	max.	30		A
Junction temperature	T_j	max.	125		$^{\circ}\text{C}$

MECHANICAL DATA

Dimensions in mm

DO - 15 (SOD - 40) The diodes are type-branded

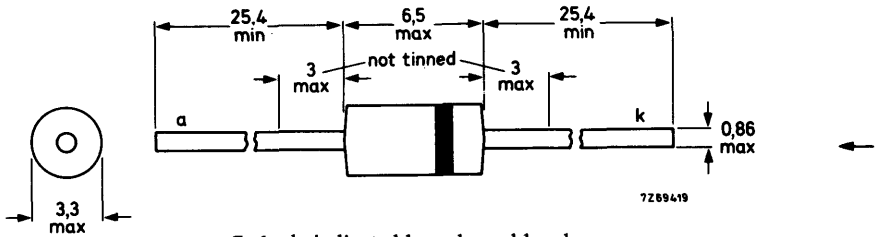

The sealing of the plastic envelope withstands the accelerated damp heat test of IEC recommendation 68-2 (test D, severity IV, 6 cycles).

Successor types are BYW54



FAST SOFT-RECOVERY RECTIFIER DIODES

Silicon double-diffused rectifier diodes in plastic envelopes. They are intended for use in inverter and converter applications, and in switched-mode power supplies, scan rectifiers in television receivers and other h. f. power supplies. The devices feature non-snap-off characteristics.

QUICK REFERENCE DATA					
			BYX55-350	600	
Working reverse voltage	V_{RW}	max.	300	500	V
Repetitive peak reverse voltage	V_{RRM}	max.	350	600	V
Average forward current	$I_{F(AV)}$	max.	1,2		A
Non-repetitive peak forward current t = 10 ms; $T_j = 125^\circ\text{C}$ prior to surge	I_{FSM}	max.	40		A
Junction temperature	T_j	max.	125		$^\circ\text{C}$
Reverse recovery charge when switched from $I_F = 1\text{ A}$ to $V_R \geq 50\text{ V}$ with $-di/dt = 1\text{ A}/\mu\text{s}$; $T_j = 25^\circ\text{C}$	Q_S	<		120	nC

MECHANICAL DATA

Dimensions in mm

SOD - 18 The diodes are type-branded

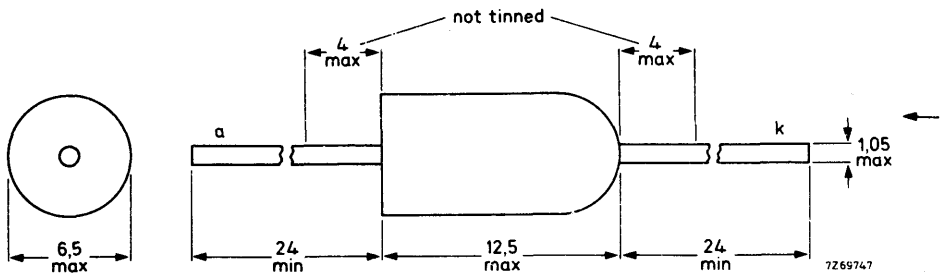

The rounded end indicates the cathode

The sealing of the plastic envelope withstands the accelerated damp heat test of IEC recommendation 68-2 (test D, severity IV, 6 cycles).

For current production only; for new designs successors BYV95 and BYW95 are recommended.



**BYX55
SERIES**

RATINGS Limiting values in accordance with the Absolute Maximum System (IEC134)

Voltages

		BYX55 - 350		-600
Continuous reverse voltage	V_R	max.	300	500 V
Working reverse voltage	V_{RW}	max.	300	500 V
Repetitive peak reverse voltage ($t \leq 10 \mu s$)	V_{RRM}	max.	350	600 V
Non-repetitive peak reverse voltage ($t \leq 10 ms$)	V_{RSM}	max.	350	600 V

Currents

Average forward current (averaged over any 20 ms period), see also pages 4 and 5	$I_{F(AV)}$	max.	1.2 A	
Repetitive peak forward current	I_{FRM}	max.	8 A	
→ Repetitive peak forward current ($\delta \leq 0.04$; $f > 15 kHz$)	I_{FRM}	max.	15 A	
Non-repetitive peak forward current ($t = 10 ms$; half sine wave) $T_j = 125^\circ C$ prior to surge	I_{FSM}	max.	40 A	
Rate of change of commutation current See also nomogram on page 6	$\frac{dI}{dt}$	max.	20 A/ μs	

Temperatures

Storage temperature	T_{stg}	-40 to +125 °C		
Junction temperature	T_j	max.	125 °C	

THERMAL RESISTANCE

See page 3

CHARACTERISTICS

Forward voltage

$I_F = 5 A$; $T_j = 25^\circ C$	V_F	<	1.25 V ¹⁾	
----------------------------------	-------	---	----------------------	--

Reverse current

$V_R = V_{RWmax}$; $T_j = 125^\circ C$	I_R	<	0.75 mA	
$V_R = V_{RWmax}$; $T_j = 25^\circ C$	I_R	<	10 μA	

Capacitance at $f = 1 MHz$

$V_R = 250 V$; $T_j = 25$ to $125^\circ C$	C_d	typ.	8 pF	
---	-------	------	------	--

¹⁾ Measured under pulse conditions to avoid excessive dissipation.

CHARACTERISTICS (continued)

Reverse recovery when switched from

$I_F = 1 \text{ A}$ to $V_R \geq 50 \text{ V}$ with $-di/dt =$
 $T_j = 25 \text{ }^\circ\text{C}$

Recovery charge

Recovery time

Fall time

	1	20	A/ μs
Q_s	< 120	400	nC
t_{rr}	< 750	350	ns
t_f	> 120	100	ns

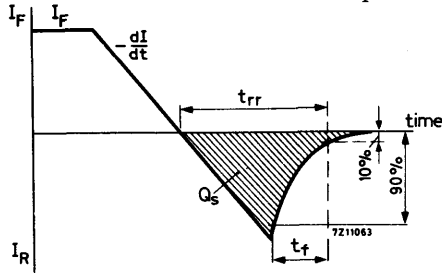

THERMAL RESISTANCE (influence of mounting method)

The quoted values of $R_{th j-a}$ should be used only when no other leads run to the tie-points. If the leads of other dissipating components share the same tie-points, the thermal resistance will be higher than that quoted.

- Mounted on solder tags at a lead-length: $a = 10 \text{ mm}$
 $a = \text{max. lead length}$

$R_{th j-a} = 60 \text{ }^\circ\text{C/W}$
 $R_{th j-a} = 70 \text{ }^\circ\text{C/W}$

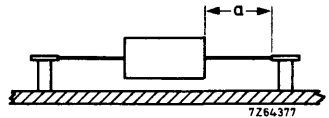

- Mounted on printed-wiring board at $a = \text{maximum lead-length}$ and heatsinks (0, 3 mm Cu) on leads.

Heatsink size 2 cm^2 (per side)

$R_{th j-a} = 60 \text{ }^\circ\text{C/W}$

Heatsink size 1 cm^2 (per side)

$R_{th j-a} = 70 \text{ }^\circ\text{C/W}$

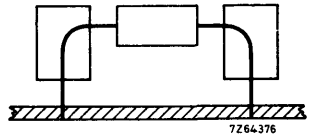

- Mounted on printed-wiring board at $a = \text{maximum lead-length}$.

$R_{th j-a} = 85 \text{ }^\circ\text{C/W}$

- Mounted on printed-wiring board at a lead-length $a = 10 \text{ mm}$.

$R_{th j-a} = 95 \text{ }^\circ\text{C/W}$

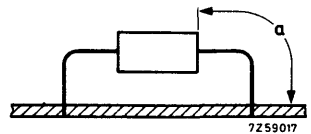

SOLDERING AND MOUNTING NOTES

- Soldered joints must be at least 5 mm from the seal.
- The maximum permissible temperature of the soldering iron or bath is $300 \text{ }^\circ\text{C}$; it must be in contact with the joint for no more than 3 seconds.
- Avoid hot spots due to handling or mounting; the body of the device must not come into contact with or be exposed to a temperature higher than $150 \text{ }^\circ\text{C}$.

BYX55 SERIES

7262352.2

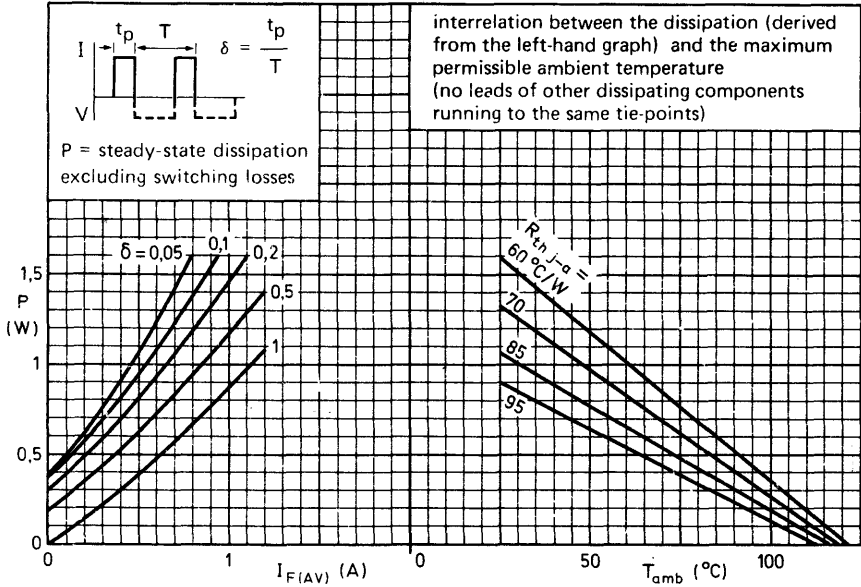

SWITCHED-MODE APPLICATION

7262350.1

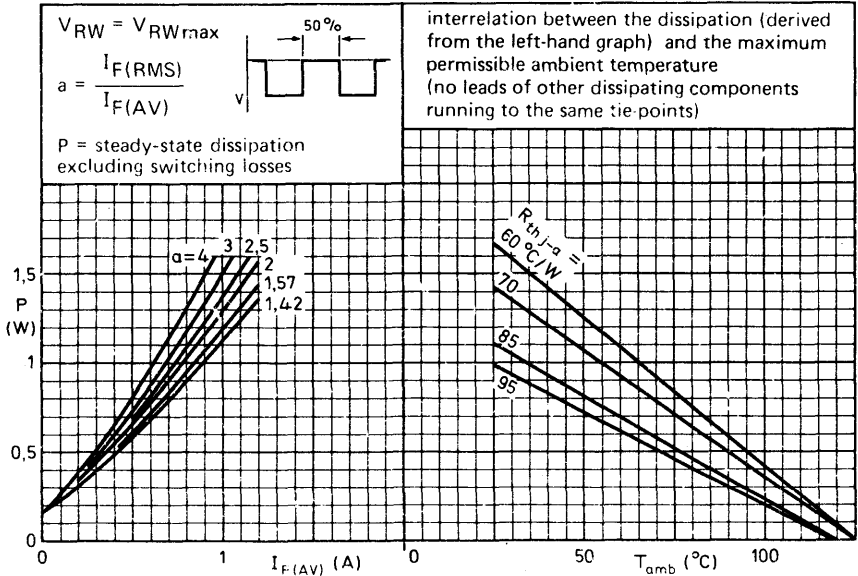

SCAN RECTIFICATION

7262351.1

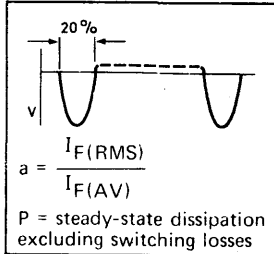

interrelation between the dissipation (derived from the left-hand graph) and the maximum permissible ambient temperature (no leads of other dissipating components running to the same tie-points)

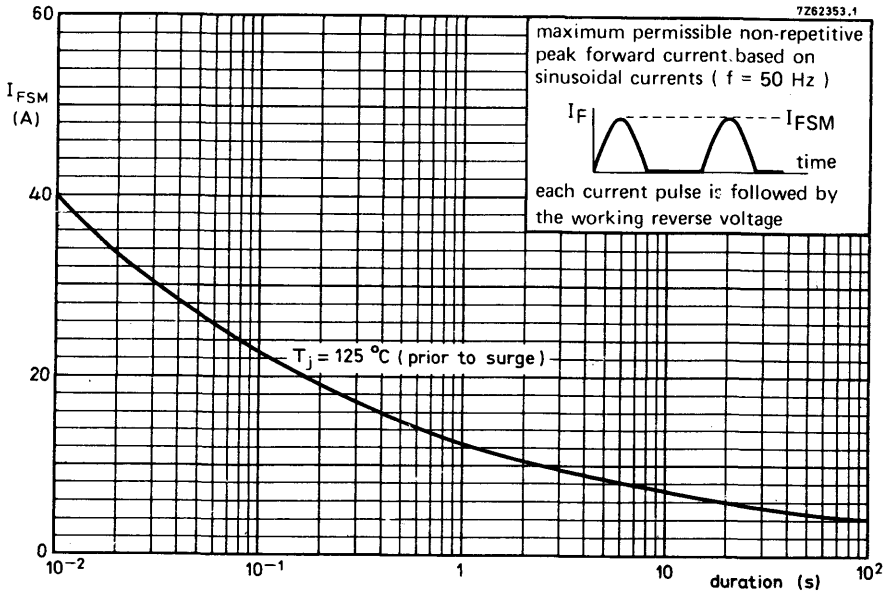
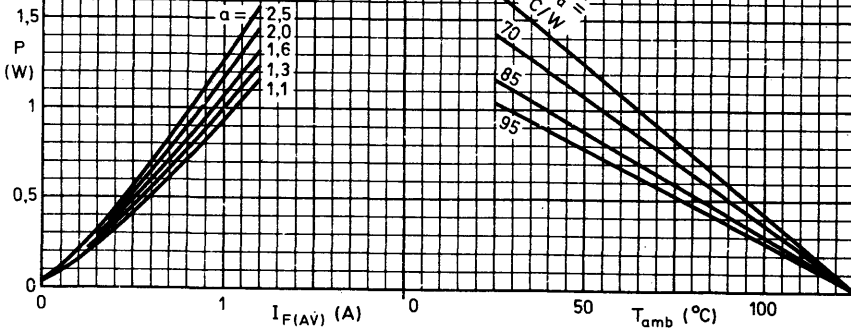

**BYX55
SERIES**

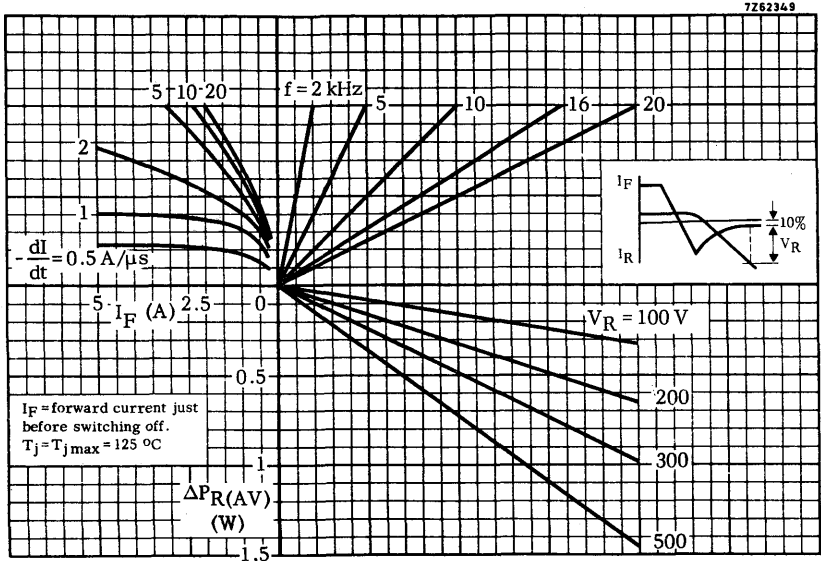

nomogram: power loss $\Delta P_{R(AV)}$ due to switching only (to be added to forward and reverse power losses)

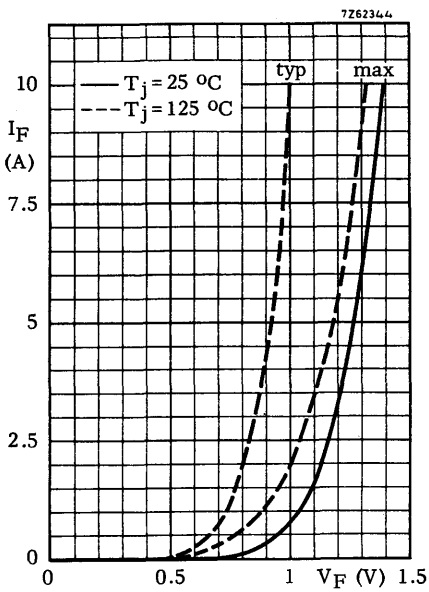

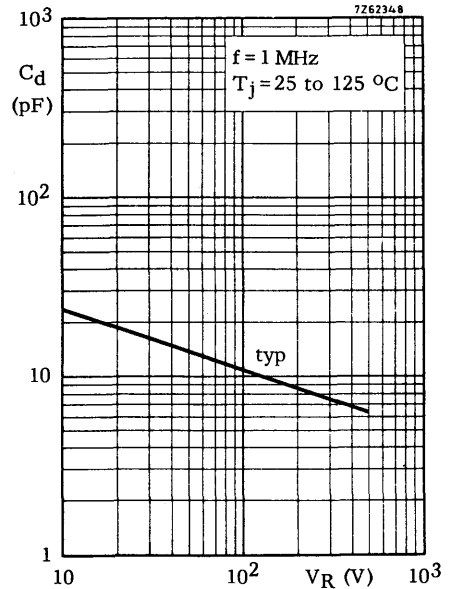
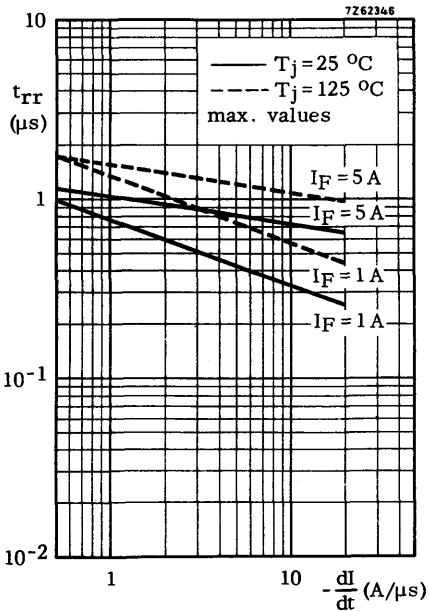
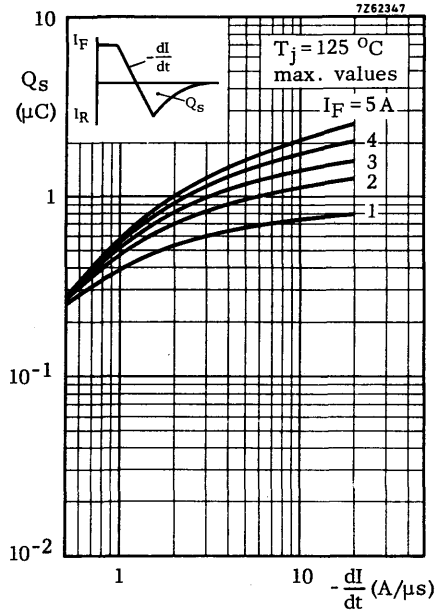
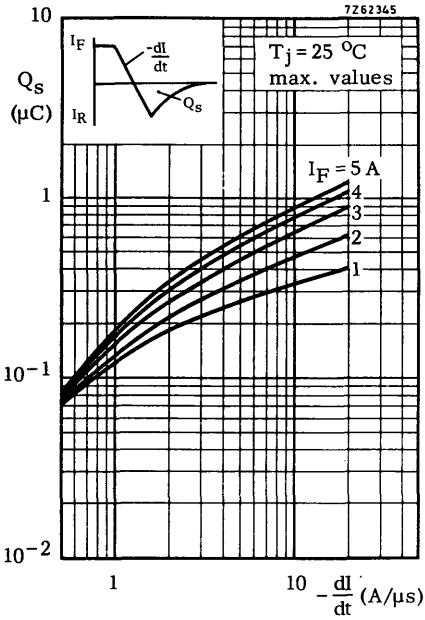

SILICON E.H.T. RECTIFIER DIODE

The BYX90 is a 6 kV silicon diode in a plastic envelope, only intended as subassembly for very high voltage stacks in X-ray equipment (in oil).

QUICK REFERENCE DATA

Crest working reverse voltage	V_{RWM}	max.	6 kV
Repetitive peak reverse voltage	V_{RRM}	max.	7,5 kV
Average forward current up to $T_{oil} = 50\text{ }^{\circ}\text{C}$	$I_{F(AV)}$	max.	200 mA
Non-repetitive peak forward current $t = 10\text{ ms}$; $T_j = 125\text{ }^{\circ}\text{C}$ prior to surge	I_{FSM}	max.	25 A
Junction temperature	T_j	max.	125 $^{\circ}\text{C}$

MECHANICAL DATA

Dimensions in mm

Fig. 1 SOD-18B.

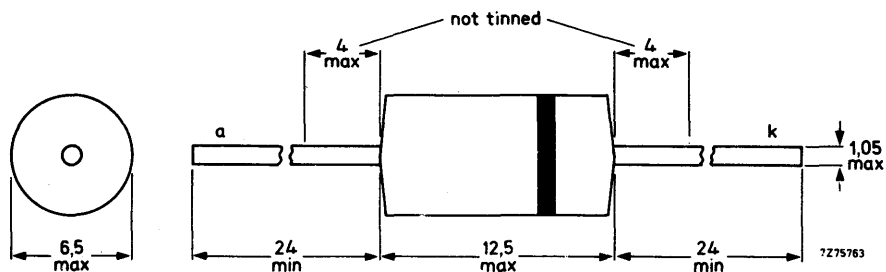

Cathode indicated by coloured band
The diodes are type-branded

All information applies to frequencies from 40 Hz to 400 Hz

RATINGS

Limiting values in accordance with the Absolute Maximum System (IEC 134)

Crest working reverse voltage	V_{RWM}	max.	6 kV
Repetitive peak reverse voltage ($\delta \leq 0,01$)	V_{RRM}	max.	7,5 kV
Non-repetitive peak reverse voltage ($t \leq 10$ ms)	V_{RSM}	max.	8 kV
Average forward current (averaged over any 20 ms period) up to $T_{oil} = 55$ °C (stirring oil) continuous operation	$I_{F(AV)}$	max.	200 mA
Repetitive peak forward current intermittent operation	I_{FRM}	max.	3 A
	see application information Figs 6 and 7		
Non-repetitive peak forward current ($t = 10$ ms; half sine wave) $T_j = 125$ °C prior to surge	I_{FSM}	max.	25 A
Storage temperature	T_{stg}		-40 to + 125 °C
Junction temperature	T_j	max.	125 °C

THERMAL RESISTANCE

From junction to cooling oil (in stirring oil)	$R_{th\ j-o}$	=	30 °C/W
--	---------------	---	---------

CHARACTERISTICS

Forward voltage

$$I_F = 2 \text{ A}; T_j = 25 \text{ °C}$$

$$V_F < 15 \text{ V}$$

Peak reverse current

$$V_R = 6 \text{ kV}; T_j = 100 \text{ °C}$$

$$I_R < 10 \text{ } \mu\text{A}$$

Reverse recovery charge when switched

$$\text{from } I_F = 200 \text{ mA to } V_R \geq 50 \text{ V} \\ \text{with } -dI_F/dt = 200 \text{ mA}/\mu\text{s}; T_j = 25 \text{ °C}$$

$$Q_s < 125 \text{ nC}$$

SOLDERING AND MOUNTING NOTES

1. Soldered joints must be at least 5 mm from the seal.
2. The maximum permissible temperature of the soldering iron or bath is 300 °C; it must not be in contact with the joint for more than 3 seconds.
3. Avoid hot spots due to handling or mounting; the body of the device must not come into contact with or be exposed to a temperature higher than 150 °C.

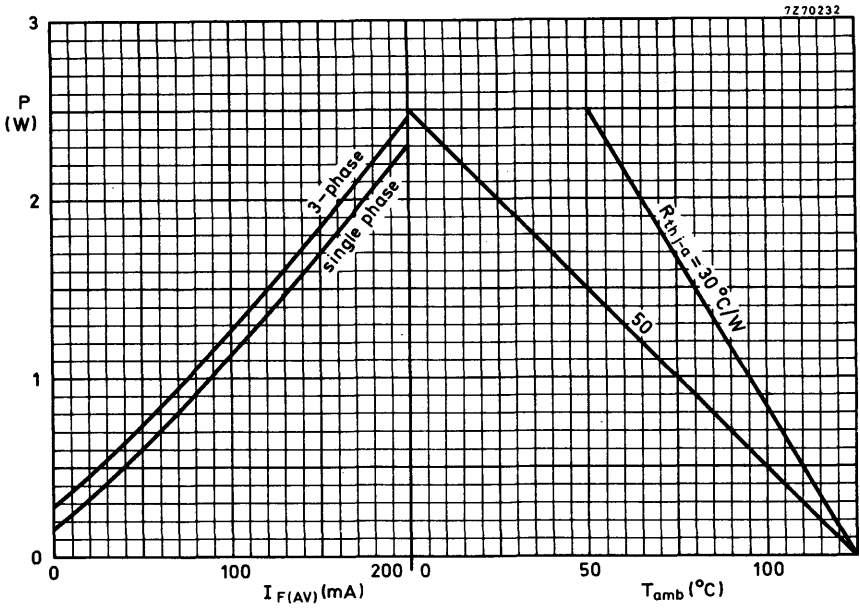

Fig. 2.

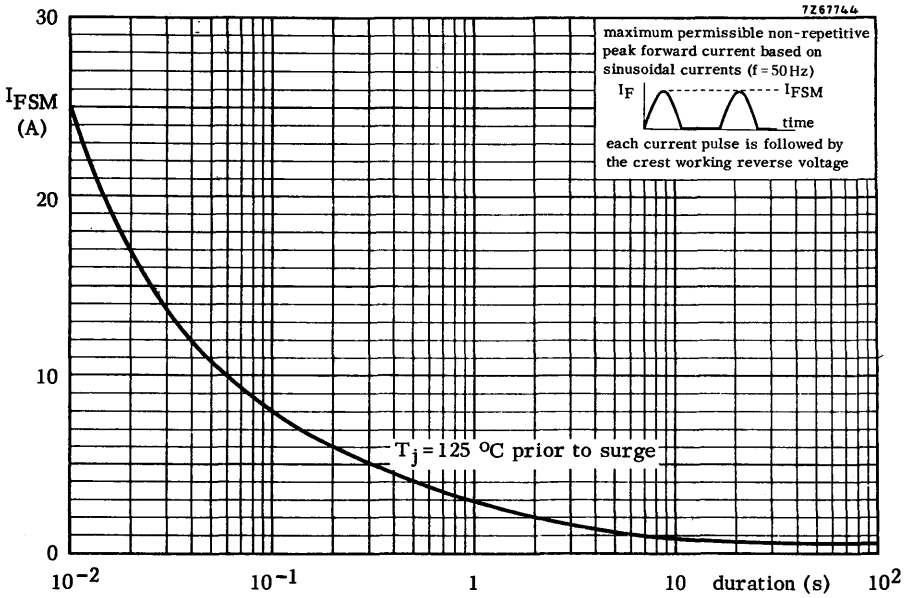

Fig. 3.

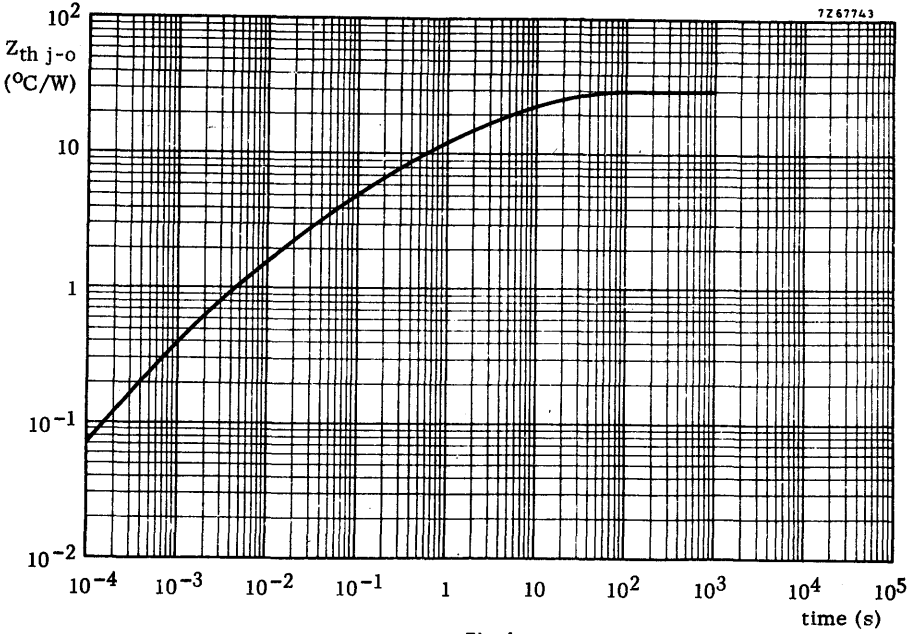

Fig. 4.

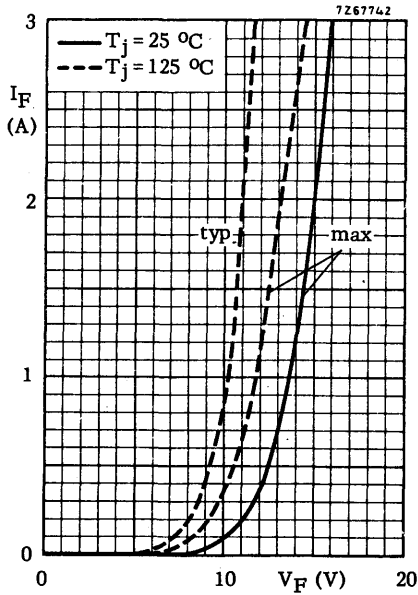

Fig. 5.

APPLICATION INFORMATION

The BYX90 used in very high voltage stacks applied in X-ray equipment.

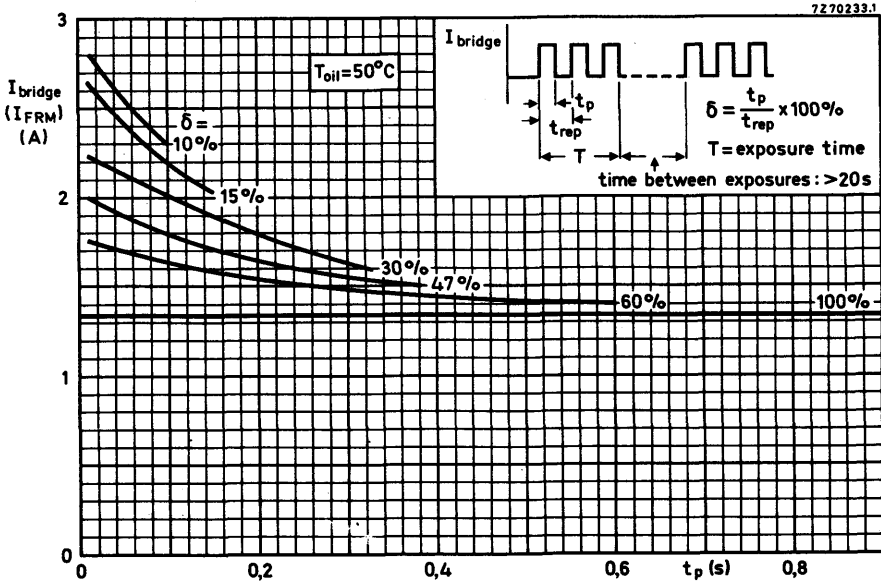

Fig. 6 Maximum current through a 3-phase rectifier bridge as a function of pulse duration. The exposure time $T = 1$ s.

APPLICATION INFORMATION (continued)

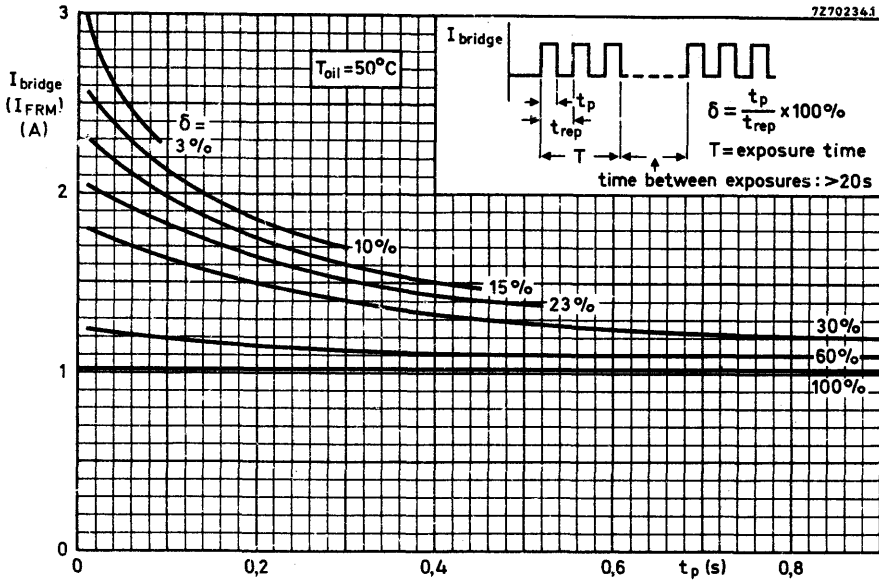

Fig. 7 Maximum current through a 3-phase rectifier bridge as a function of pulse duration. The exposure time $T = 3$ s.

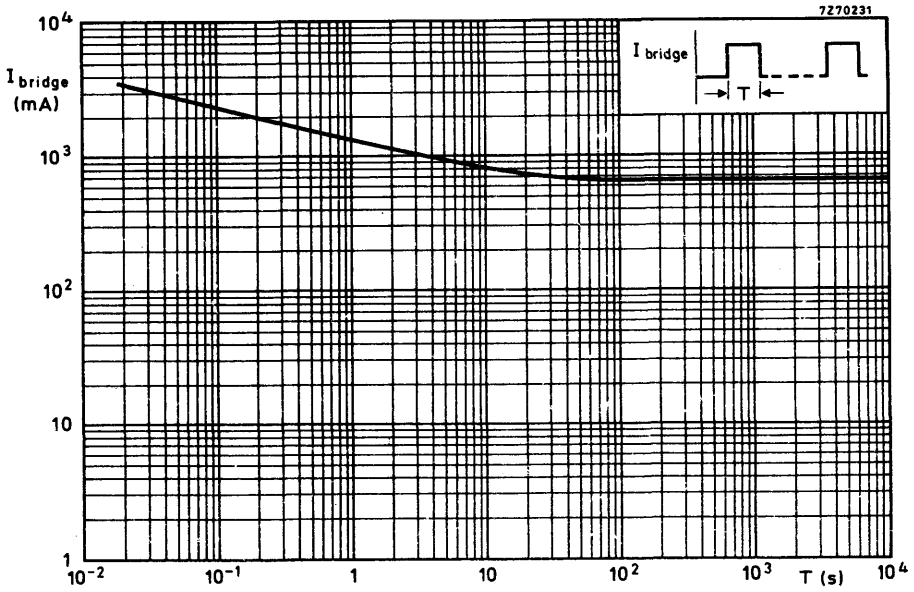

Fig. 8 Maximum permissible output current in a 3-phase rectifier bridge with a minimum time between exposures of 20 s.



SILICON E.H.T. RECTIFIER DIODES

The BYX91 series are silicon high-voltage rectifiers capable of absorbing transients. They are primarily intended for X-ray applications. This series is a direct replacement of the BYX29 series. Each rectifier consists of an appropriate number of diodes encapsulated in a synthetic resin-bonded paper tube.

For cooling and insulation reasons, the devices can only be used when immersed in oil. The series consists of the following types:

BYX91- 90K (replaces BYX29- 75 000); BYX91-150K (replaces BYX29-125 000);
BYX91-120K (replaces BYX29-100 000); BYX91-180K (replaces BYX29-150 000).

QUICK REFERENCE DATA						
		BYX91-90K	120K	150K	180K	
Crest working reverse voltage	V_{RWM}	max. 90	120	150	180	kV
Average forward current	$I_{F(AV)}$	max. 200	200	200	200	mA
Non-repetitive peak forward current; $t = 10$ ms	I_{FSM}	max. 25	25	25	25	A
Junction temperature	T_j	max. 125	125	125	125	°C
Thermal resistance from junction to cooling oil	$R_{th j-o}$	= 2	1,5	1,2	1	°C/W

MECHANICAL DATA

Dimensions in mm

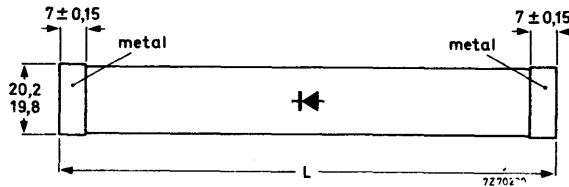

The diodes are type-branded

BYX91- 90K	L: 141 to 143 mm	Weight: 47 g
BYX91-120K	L: 169 to 171 mm	Weight: 54 g
BYX91-150K	L: 229 to 231 mm	Weight: 65 g
BYX91-180K	L: 229 to 231 mm	Weight: 70 g



All information applies to frequencies up to 400 Hz

RATINGS Limiting values in accordance with the Absolute Maximum System (IEC134)

<u>Voltages</u>		BYX91-90K	120K	150K	180K
Crest working reverse voltage	V_{RWM}	max. 90	120	150	180 kV
Crest working reverse voltage; $t \leq 10$ min	V_{RWM}	max. 100	130	165	195 kV
Repetitive peak reverse voltage; $\delta \leq 0,01$	V_{RRM}	max. 115	150	190	225 kV
Non-repetitive peak reverse voltage; $t = 10$ ms	V_{RSM}	max. 120	160	200	240 kV

Currents

Average forward current (averaged over any 20 ms period) at $T_{oil} = 50$ °C

continuous operation	$I_{F(AV)}$	max.	200 mA
intermittent operation ($t \leq 0,1$ s, once every 20 s)	$I_{F(AV)}$	max.	800 mA

Repetitive peak forward current

continuous operation	I_{FRM}	max.	600 mA
intermittent operation ($I_{F(AV)} = 800$ mA; $t \leq 0,1$ s once every 20 s)	I_{FRM}	max.	2400 mA

Non-repetitive peak forward current; $t = 10$ ms

I_{FSM}	max.	25 A
-----------	------	------

Temperatures

Storage temperature	T_{stg}	-30 to +125 °C
Junction temperature	T_j	max. 125 °C

THERMAL RESISTANCE

	BYX91-90K	120K	150K	180K
From junction to cooling oil (stirring oil)	$R_{thj-o} = 2$	1,5	1,2	1 °C/W

CHARACTERISTICS

Forward voltage

	BYX91-90K	120K	150K	180K
$I_F = 2$ A; $T_j = 25$ °C	$V_F < 225$	300	375	450 V

Peak reverse current at $T_j = 125$ °C

$V_{RM} = V_{WRMmax}$ at $t = 10$ min	$I_{RM} < 10$	10	10	10 μ A
---------------------------------------	---------------	----	----	------------

MOUNTING NOTES

1. The rectifier stack shall be used in cooling (insulating) oil.
2. It should be made possible that the oil can circulate freely through the stacks.
3. Horizontal mounting should be avoided.

BYX91 SERIES

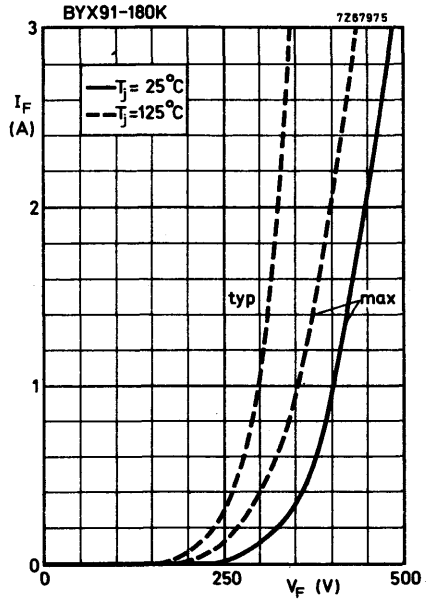
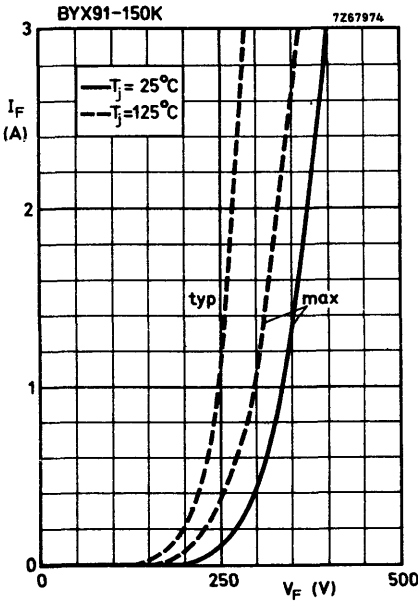
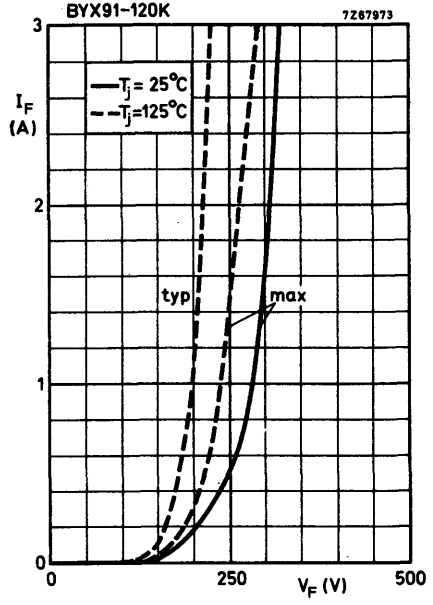
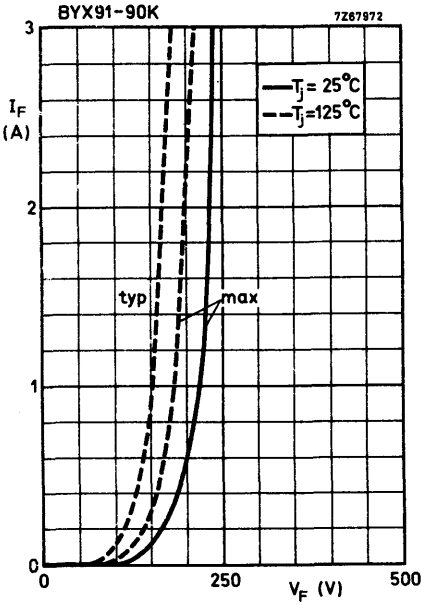

**BYX91
SERIES**

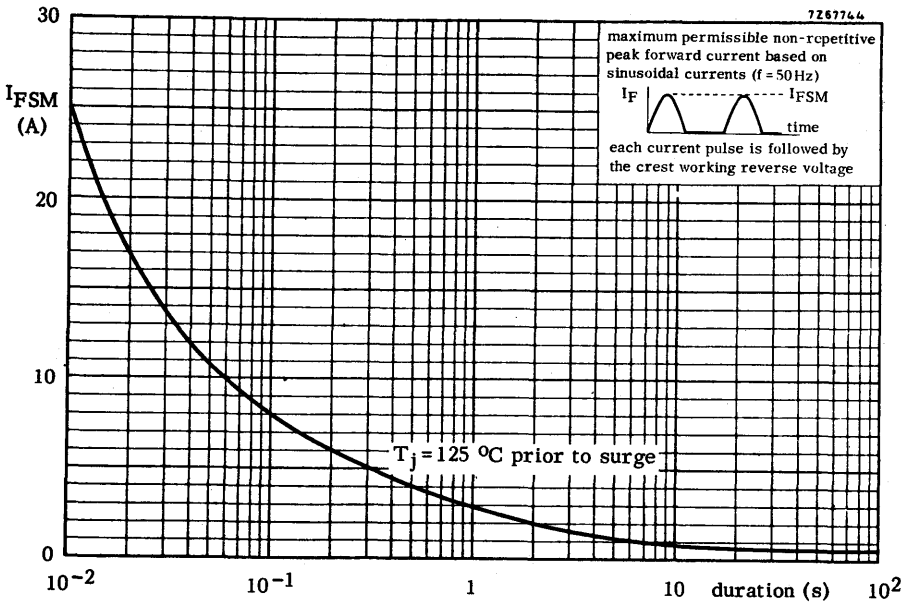
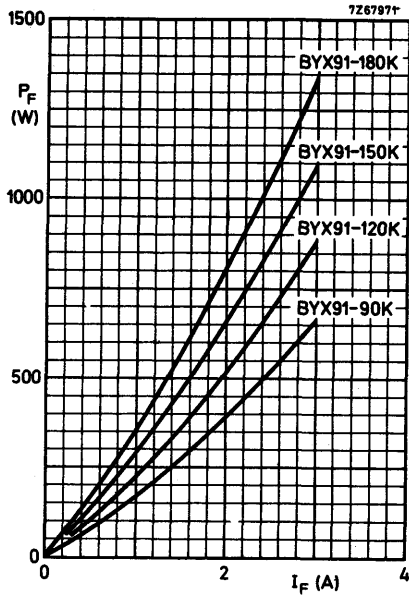

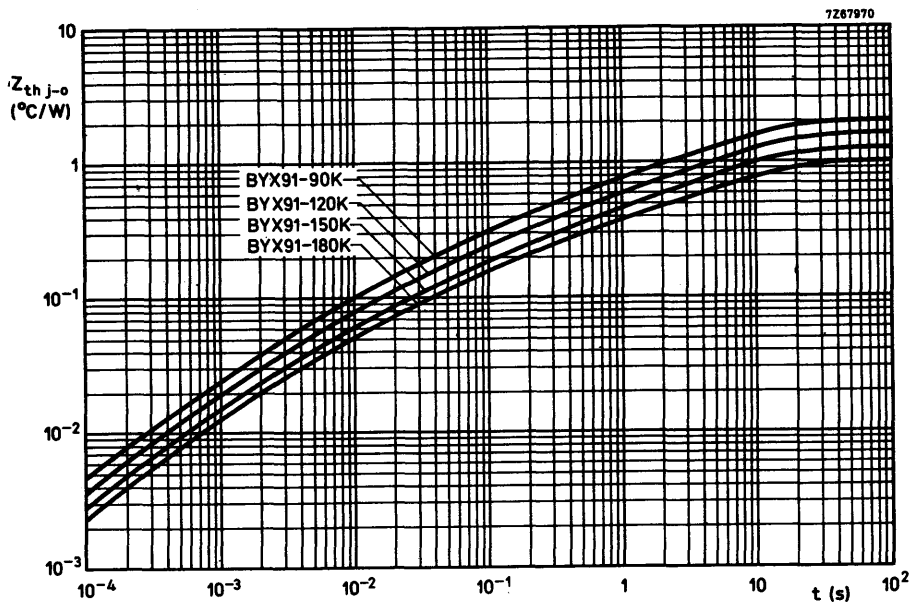



SILICON DIFFUSED RECTIFIER DIODES

1N4001 to 1N4007

A range of plastic encapsulated silicon diffused rectifier diodes for general purpose use.

QUICK REFERENCE DATA							
	1N4001	1N4002	1N4003	1N4004	1N4005	1N4006	1N4007
V_R max.	50	100	200	400	600	800	1000 V
V_{RRM} max.	50	100	200	400	600	800	1000 V
$I_F(AV)$ max. ($T_{amb} = -65$ to $+75^\circ C$)				1.0			
T_j max.				175			
							A
							$^\circ C$

Unless otherwise shown data are applicable to all types in the series

OUTLINE AND DIMENSIONS

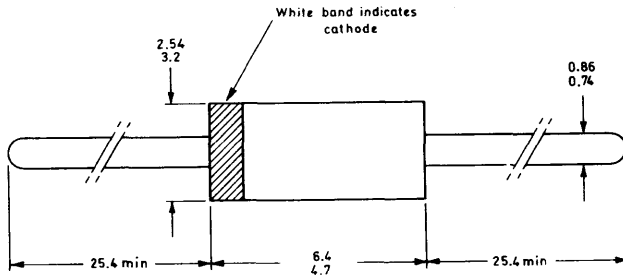

All dimensions in mm

D2523a

The diodes are type branded

Mullard

RATINGS

Limiting values of operation according to the absolute maximum system

Electrical

	1N4001	1N4002	1N4003	1N4004	1N4005	1N4006	1N4007		
V_R max.	50	100	200	400	600	800	1000	V	
V_{RRM} max.	50	100	200	400	600	800	1000	V	
$I_{F(AV)}$ max.	Average half-wave rectified forward current, $T_{amb} \leq 75^\circ\text{C}$					1.0		A	
						= 100°C		0.75	A
I_F max.	D.C. forward current					See graph on page 3			
I_{FRM} max.	Repetitive peak forward current					10		A	
I_{FSM} max.	Non-repetitive peak forward current (half-cycle surge, 60c.p.s.)					30		A	

Temperature

T_{stg}	Storage temperature	-65 to +175	$^\circ\text{C}$
T_j max.	Junction temperature	175	$^\circ\text{C}$

ELECTRICAL CHARACTERISTICS ($T_{amb} = 25^\circ\text{C}$ unless otherwise stated)

V_F	Forward voltage drop $I_F = 1.0\text{A d.c.}$	Max.	1.1	V
$V_{F(AV)}$	Full-cycle average forward voltage drop $I_{F(AV)} = 1.0\text{A}$		0.8	V
I_R	Reverse current $V_R = \text{max.}, T_{amb} = 25^\circ\text{C}$		10	μA
	$T_{amb} = 100^\circ\text{C}$		50	μA
$I_{R(AV)}$	Full-cycle average reverse current $V_{RRM} = \text{max.}, T_{amb} = 75^\circ\text{C}$		30	μA

SOLDERING RECOMMENDATIONS

At a maximum iron temperature of 300°C , the maximum permissible soldering time is 3 seconds, provided the soldering spot is at least 5mm from the seal.

DIP SOLDERING

At a maximum solder temperature of 300°C , the maximum permissible soldering time is 3 seconds, the soldering spot being not less than 5mm from the seal.

Note: If the diode is in contact with the printed board the maximum permissible temperature of the point is 175°C .

SILICON DIFFUSED RECTIFIER DIODES

1N4001 to 1N4007

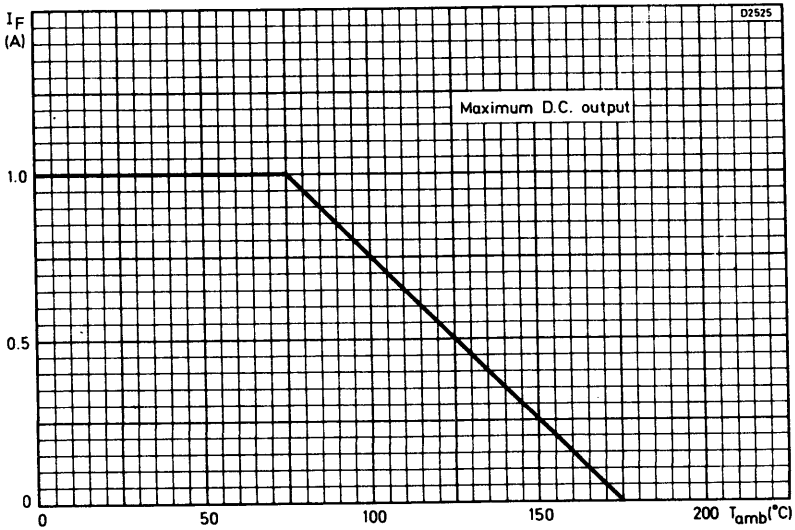
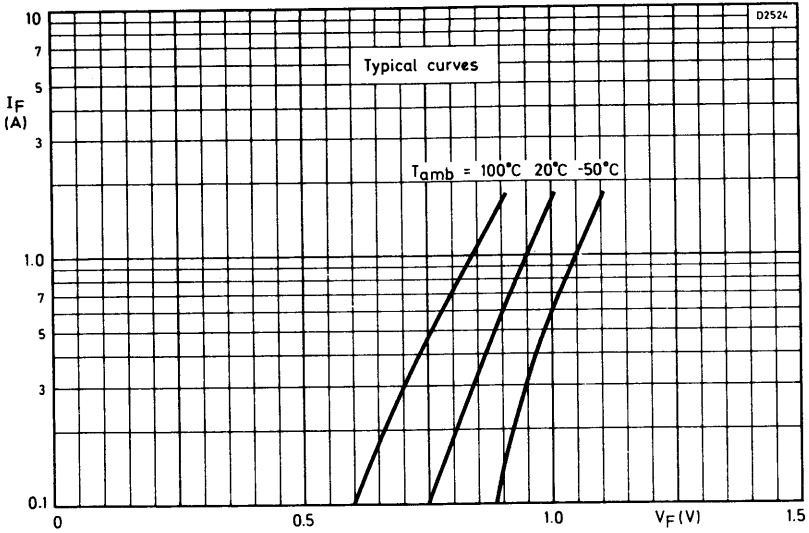

Mullard



GERMANIUM DIODES

**Point contact
Gold bonded**

F 



POINT CONTACT DIODE

Germanium diode in all-glass DO-7 envelope primarily intended for use in a.m. detector and ratio detector circuits.

QUICK REFERENCE DATA

Continuous reverse voltage	V_R	max.	30 V
Repetitive peak reverse voltage	V_{RRM}	max.	45 V
Forward current (d.c.)	I_F	max.	35 mA
Repetitive peak forward current	I_{FRM}	max.	100 mA
Operating ambient temperature	T_{amb}	max.	60 °C
Forward voltage at $I_F = 10$ mA	V_F	<	2,2 V

MECHANICAL DATA

Dimensions in mm.

Fig. 1 DO-7.

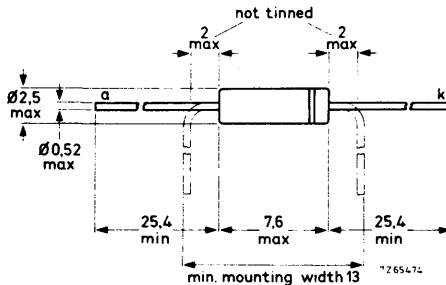

The diodes may be supplied either type-branded or with a broad *white* cathode band.

Available for current production only; not recommended for new designs.



RATINGS

Limiting values in accordance with the Absolute Maximum System (IEC 134)

Continuous reverse voltage	V_R	max.	30 V
Repetitive peak reverse voltage	V_{RRM}	max.	45 V
Forward current (d.c.)	I_F	max.	35 mA
Average rectified forward current (averaged over any 50 ms period)	$I_{F(AV)}$	max.	35 mA
Repetitive peak forward current	I_{FRM}	max.	100 mA
Non-repetitive peak forward current ($t < 1$ s)	I_{FSM}	max.	200 mA
Storage temperature	T_{stg}		-65 to +75 °C
Operating ambient temperature	T_{amb}	max.	60 °C

THERMAL RESISTANCE

From junction to ambient in free air

$$R_{th\ j-a} = 0,65 \text{ } ^\circ\text{C/mW}$$

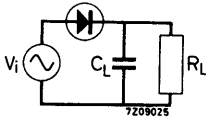
Dynamic characteristics

	1	3	3	V
V_{im}	0,47	10,7	38,15	MHz
f	50	330	33	pF
C_L	1,0	0,033	0,082	MΩ
R_L	85	85	85	%
η	370	15	30	kΩ
R_d				

CHARACTERISTICS

Forward voltage at $T_{amb} = 25\text{ }^{\circ}\text{C}$ $I_F = 0,1\text{ mA}$

V_F	typ.	0,23 V
	<	0,30 V

 $I_F = 1\text{ mA}$

V_F	typ.	0,56 V
	<	0,88 V

 $I_F = 10\text{ mA}$

V_F	typ.	1,5 V
	<	2,2 V

 $I_F = 30\text{ mA}^*$

V_F	typ.	2,8 V
	<	4,0 V

Forward voltage at $T_{amb} = 60\text{ }^{\circ}\text{C}$ $I_F = 0,1\text{ mA}$

V_F	typ.	0,16 V
	<	0,25 V

 $I_F = 1\text{ mA}$

V_F	typ.	0,50 V
	<	0,80 V

 $I_F = 10\text{ mA}$

V_F	typ.	1,4 V
	<	2,1 V

 $I_F = 30\text{ mA}^*$

V_F	typ.	2,6 V
	<	3,8 V

Reverse current at $T_{amb} = 25\text{ }^{\circ}\text{C}$ $V_R = 0,1\text{ V}$

I_R	typ.	0,35 μA
	<	1,0 μA

 $V_R = 1,5\text{ V}$

I_R	typ.	0,8 μA
	<	2,8 μA

 $V_R = 10\text{ V}$

I_R	typ.	4,5 μA
	<	18 μA

 $V_R = 30\text{ V}$

I_R	typ.	35 μA
	<	150 μA

 $V_R = 45\text{ V}$

I_R	typ.	90 μA
	<	350 μA

Reverse current at $T_{amb} = 60\text{ }^{\circ}\text{C}$ $V_R = 0,1\text{ V}$

I_R	typ.	4,5 μA
	<	12 μA

 $V_R = 1,5\text{ V}$

I_R	typ.	6 μA
	<	25 μA

 $V_R = 10\text{ V}$

I_R	typ.	16 μA
	<	60 μA

 $V_R = 30\text{ V}$

I_R	typ.	60 μA
	<	300 μA

 $V_R = 45\text{ V}$

I_R	typ.	170 μA
	<	500 μA

* Measured under pulsed conditions to prevent excessive dissipation.

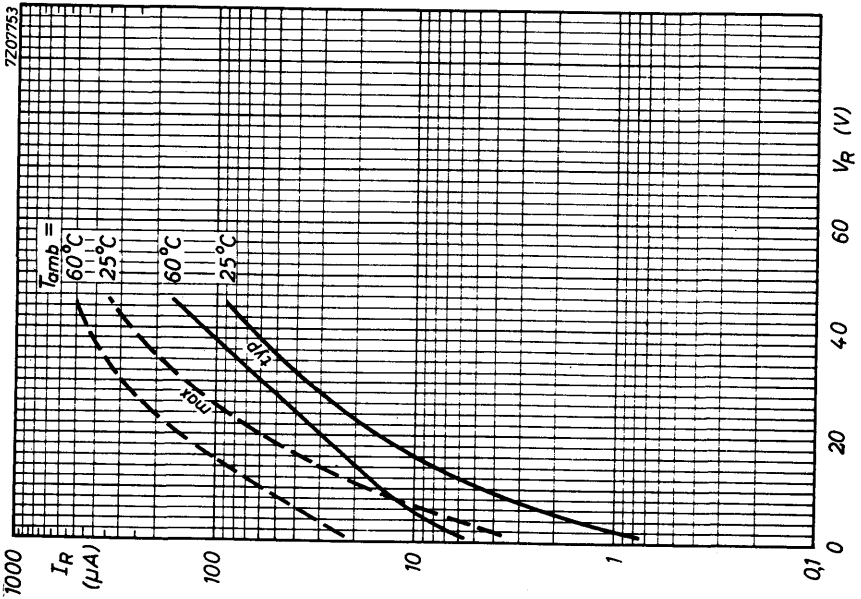
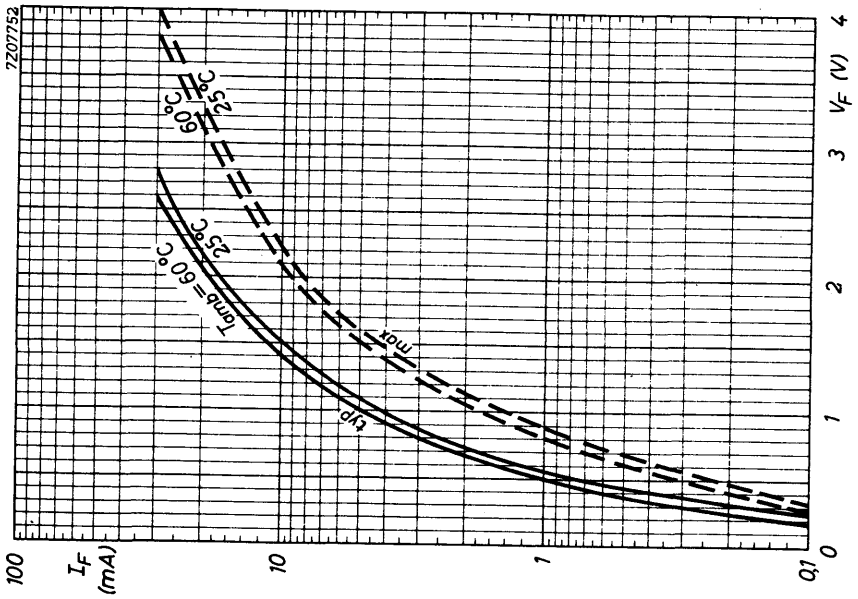

POINT CONTACT DIODE

Germanium diode in all-glass DO-7 envelope for use as video detector and for general purposes.

QUICK REFERENCE DATA

Continuous reverse voltage	V_R	max.	20 V
Repetitive peak reverse voltage	V_{RRM}	max.	30 V
Forward current (d.c.)	I_F	max.	8 mA
Repetitive peak forward current	I_{FRM}	max.	45 mA
Operating ambient temperature	T_{amb}	max.	75 °C
Forward voltage at $I_F = 30$ mA	V_F	<	3,2 V

MECHANICAL DATA

Dimensions in mm

Fig. 1 DO-7.

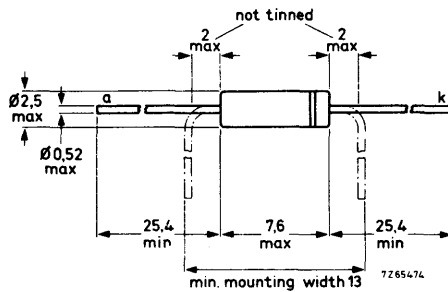

The diodes may be supplied either type-branded or with a broad *black* cathode band.

Available for current production only; not recommended for new designs.



RATINGS

Limiting values in accordance with the Absolute Maximum System (IEC 134)

Average reverse voltage (averaged over any 50 ms period)	V_R	max.	20 V
Repetitive peak reverse voltage	V_{RRM}	max.	30 V
Non-repetitive peak reverse voltage	V_{RSM}	max.	40 V
Average forward current (averaged over any 50 ms period)	$I_F(AV)$	max.	10 mA
Repetitive peak forward current	I_{FRM}	max.	45 mA
Non-repetitive peak forward current ($t < 1$ s)	I_{FSM}	max.	200 mA
Storage temperature	T_{stg}		-65 to + 90 °C
Operating ambient temperature	T_{amb}		-55 to + 75 °C

CHARACTERISTICS

Forward voltage

$I_F = 0,1$ mA

	$T_{amb} = 25$ °C	60 °C
V_F	typ. 0,18 0,1 to 0,25	typ. 0,12 V < 0,20 V
V_F	typ. 1,0 0,5 to 1,5	typ. 0,95 V 0,4 to 1,4 V
V_F	typ. 2,0 1,1 to 3,2	typ. 1,95 V 1,0 to 3,1 V

$I_F = 10$ mA

$I_F = 30$ mA

Reverse current

$V_R = 1,5$ V

$V_R = 10$ V

$V_R = 20$ V

$V_R = 30$ V

I_R	typ. 2,4 < 10	typ. 11 μ A < 40 μ A
I_R	typ. 20 < 135	typ. 45 μ A < 270 μ A
I_R	typ. 90 < 450	typ. 140 μ A < 650 μ A
I_R	typ. 300 < 1100	typ. 400 μ A < 1500 μ A

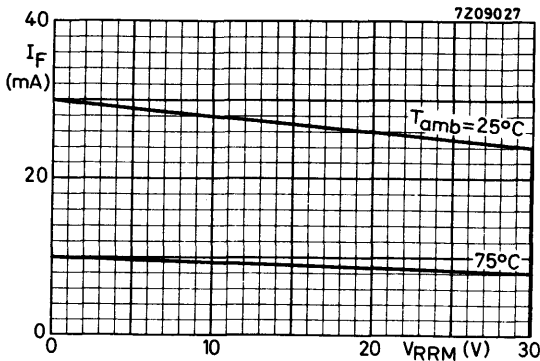
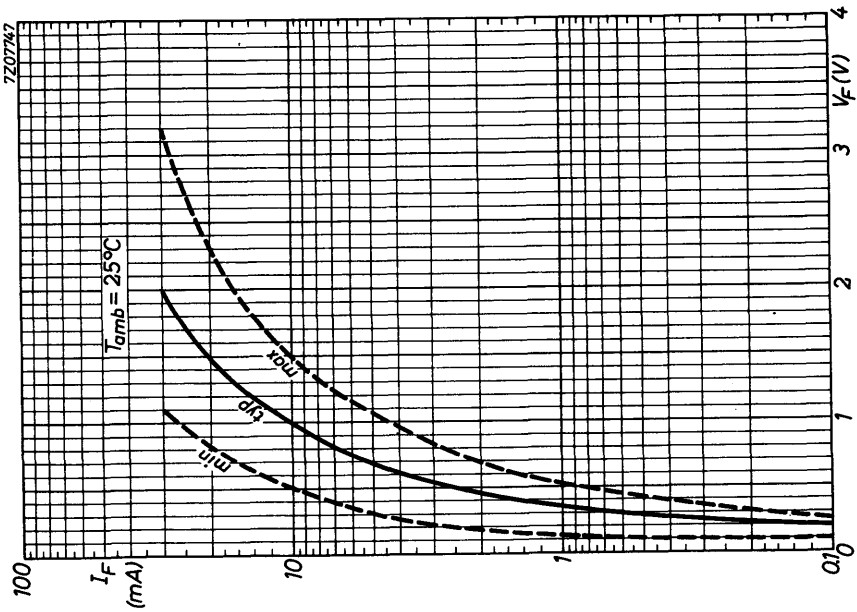
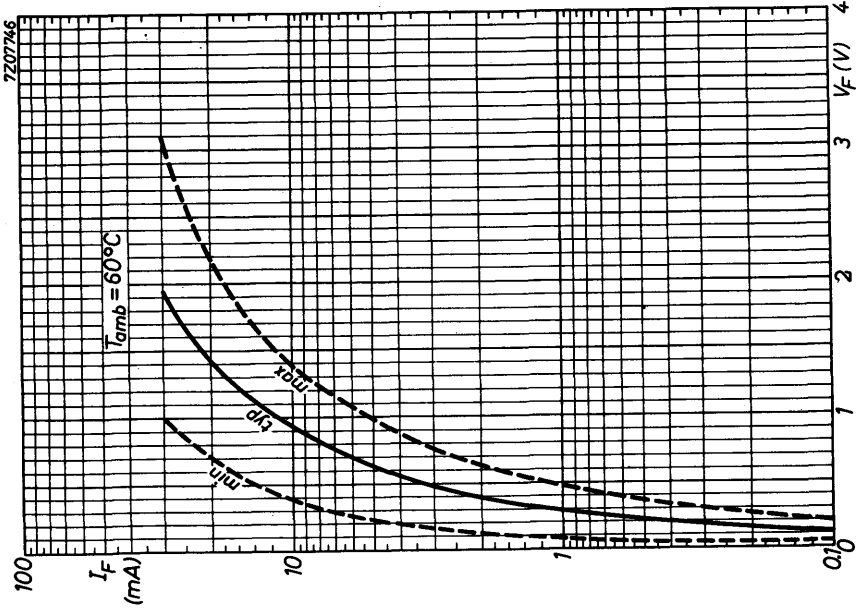
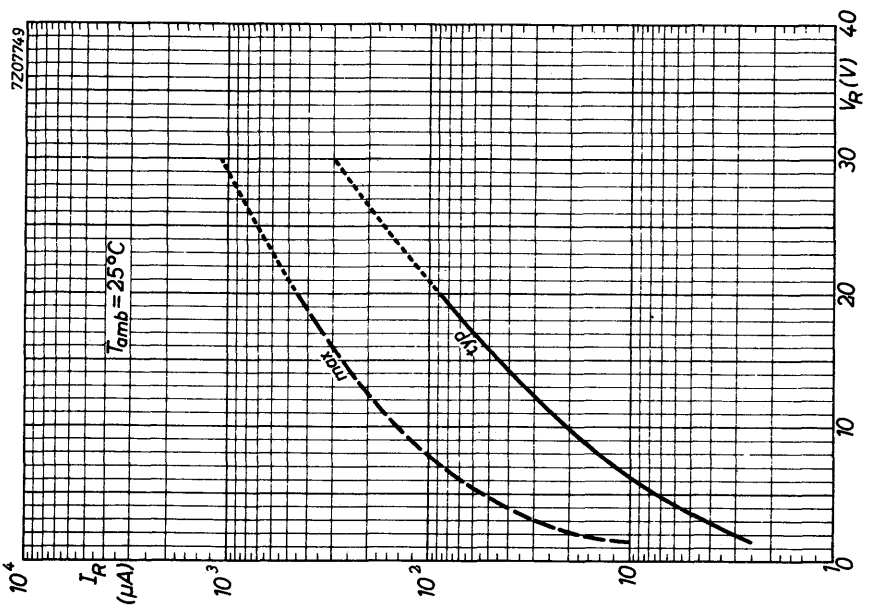
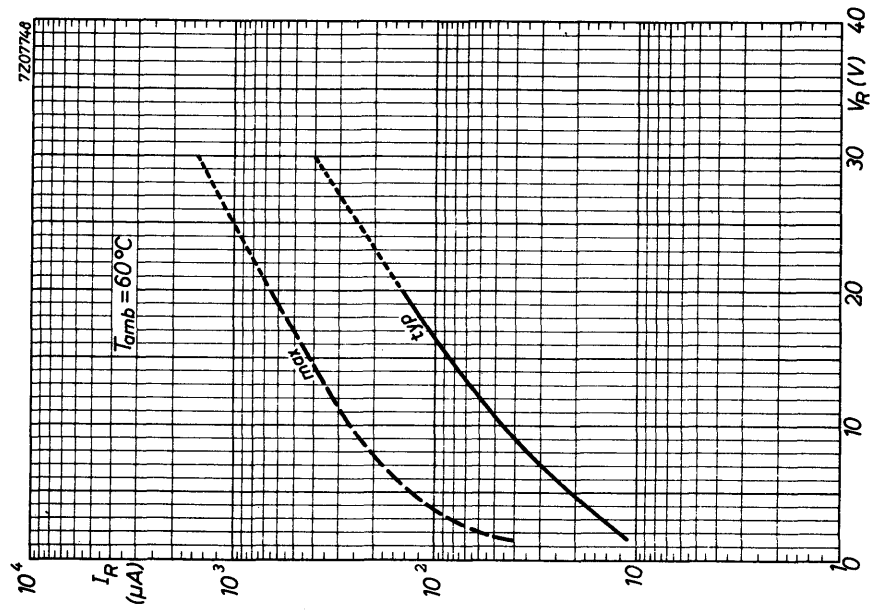
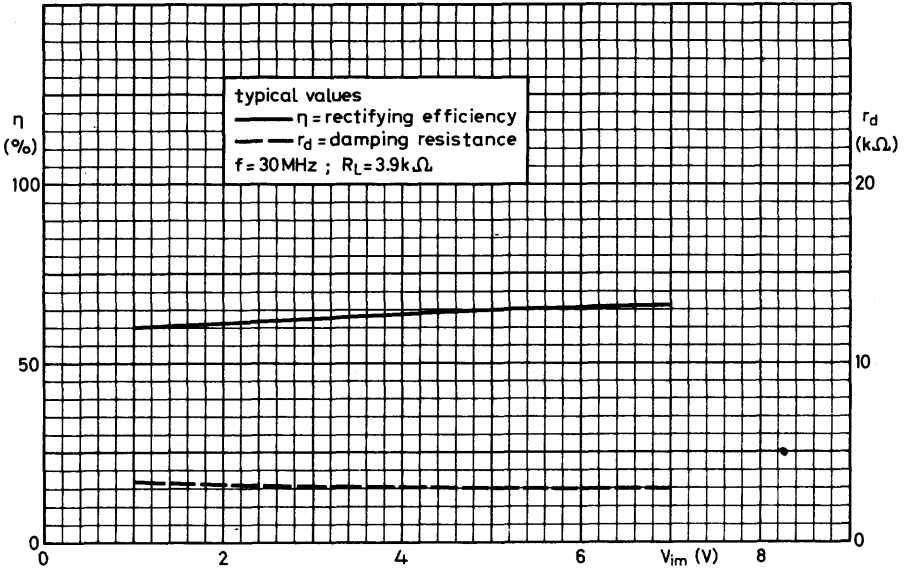

Fig. 2 Derating curve.





7210603



Dynamic characteristics

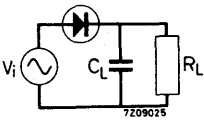

f	30	40	40	40	MHz
$V_{in(pk)}$	5,0	5,0	1,4	0,5	V
R_L	3,9	3,0	3,0	3,0	k Ω
C_L	10	10	10	10	pF
η	60	63	54	34	%
R_d	2,9	2,4	2,8	3,7	k Ω

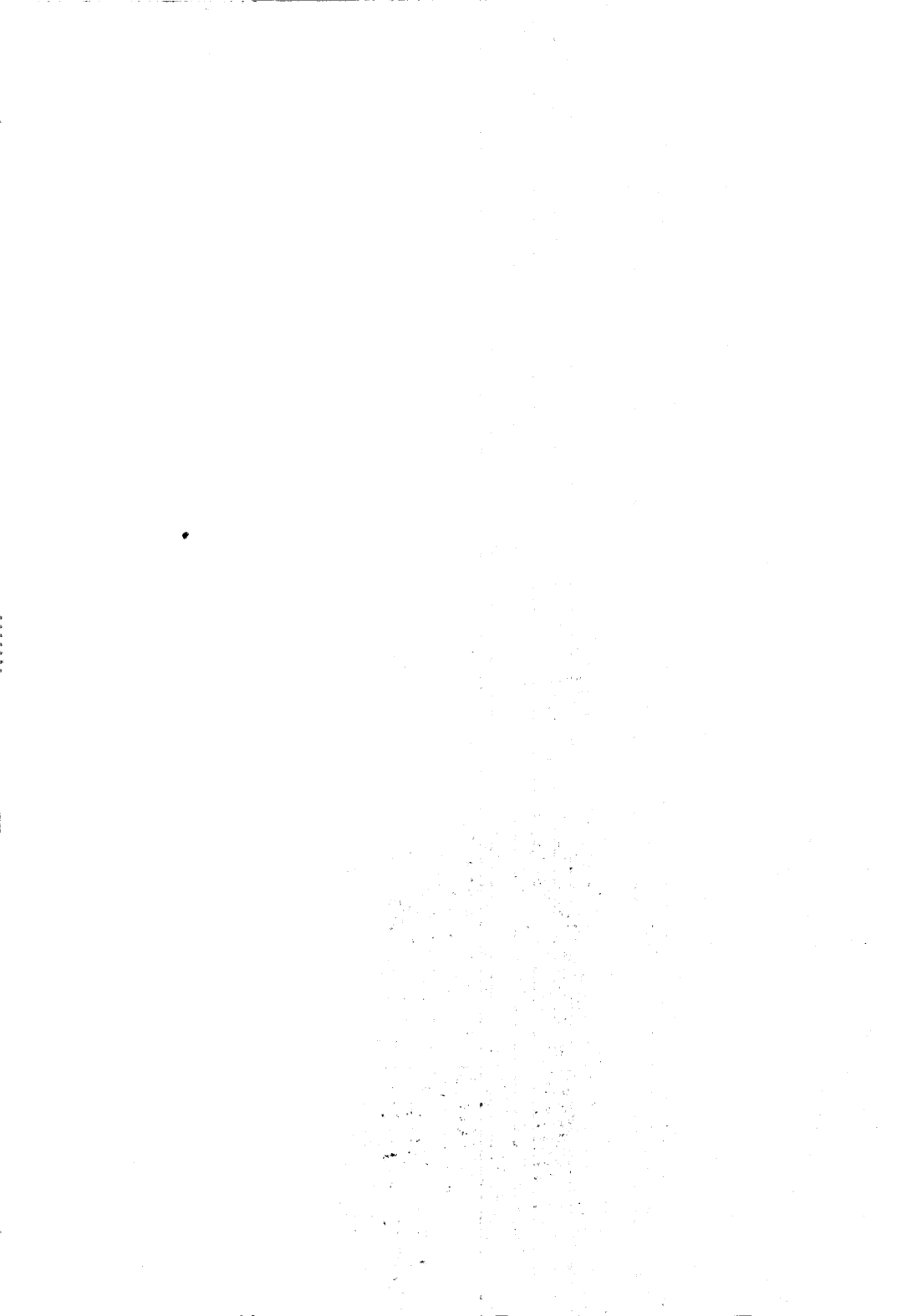

POINT CONTACT DIODE

Germanium diode in all-glass DO-7 envelope intended for general purposes.

QUICK REFERENCE DATA

Continuous reverse voltage	V_R	max.	90 V
Repetitive peak reverse voltage	V_{RRM}	max.	115 V
Forward current (d.c.)	I_F	max.	50 mA
Repetitive peak forward current	I_{FRM}	max.	150 mA
Operating ambient temperature	T_{amb}	max.	75 °C
Forward voltage at $I_F = 30$ mA	V_F	<	3,3 V

MECHANICAL DATA

Dimensions in mm

Fig. 1 DO-7.

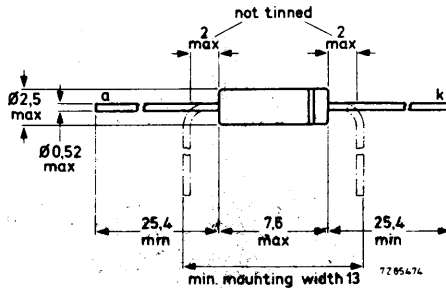

The diodes may be supplied either type-branded or with a broad *red* cathode band.

Available for current production only; not recommended for new designs.



Mullard

RATINGS

Limiting values in accordance with the Absolute Maximum System (IEC 134)

Average reverse voltage (averaged over any 50 ms period)	V_R	max. 90 V
Repetitive peak reverse voltage	V_{RRM}	max. 115 V
Average forward current (averaged over any 50 ms period)	$I_{F(AV)}$	max. 50 mA
Repetitive peak forward current	I_{FRM}	max. 150 mA
Non-repetitive peak forward current ($t < 1$ s)	I_{FSM}	max. 500 mA
Storage temperature	T_{stg}	-65 to +75 °C
Ambient temperature	T_{amb}	-55 to +75 °C

THERMAL RESISTANCE

From junction to ambient in free air

$R_{thj-a} = 0,55 \text{ } ^\circ\text{C/mW}$

CHARACTERISTICS

Forward voltage

$I_F = 0,1 \text{ mA}$

$I_F = 10 \text{ mA}$

$I_F = 30 \text{ mA}$

Reverse current

$V_R = 1,5 \text{ V}$

$V_R = 10 \text{ V}$

$V_R = 75 \text{ V}$

$V_R = 100 \text{ V}$

	$T_{amb} = 25 \text{ } ^\circ\text{C}$	$T_{amb} = 60 \text{ } ^\circ\text{C}$
V_F	typ. 0,18 0,1 to 0,25	typ. 0,1 V 0,05 to 0,2 V
V_F	typ. 1,2 0,65 to 1,9	typ. 1,05 V 0,55 to 1,8 V
V_F	typ. 2,1 1,0 to 3,3	typ. 1,9 V 0,9 to 3,15 V
I_R	typ. 1,5 0,3 to 7	typ. 15 μA 6 to 45 μA
I_R	typ. 4 0,5 to 11	typ. 20 μA 9 to 60 μA
I_R	typ. 40 5,5 to 180	typ. 115 μA 35 to 260 μA
I_R	typ. 75 10 to 275	typ. 190 μA 60 to 450 μA

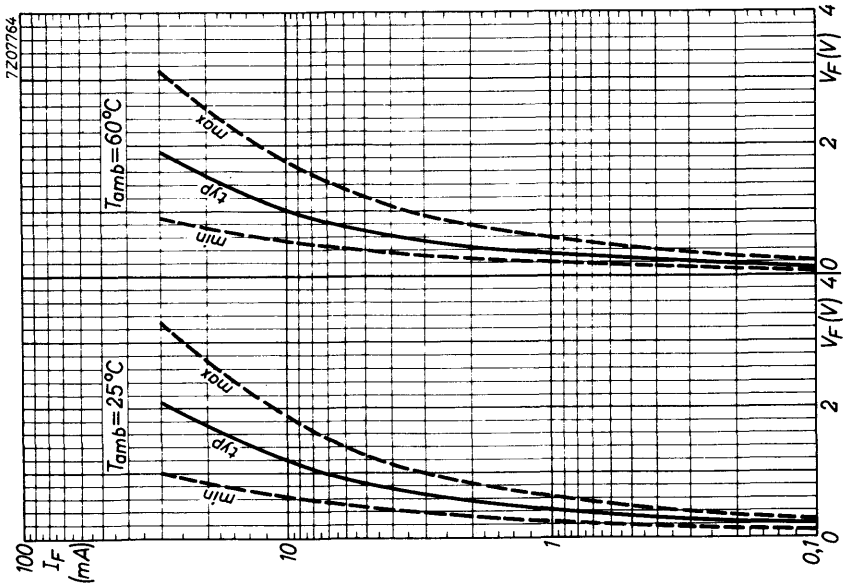
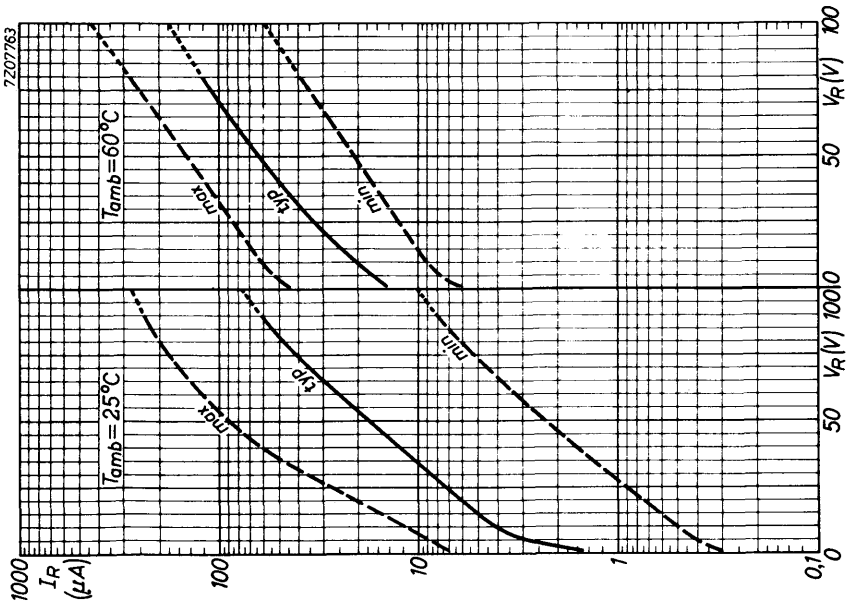

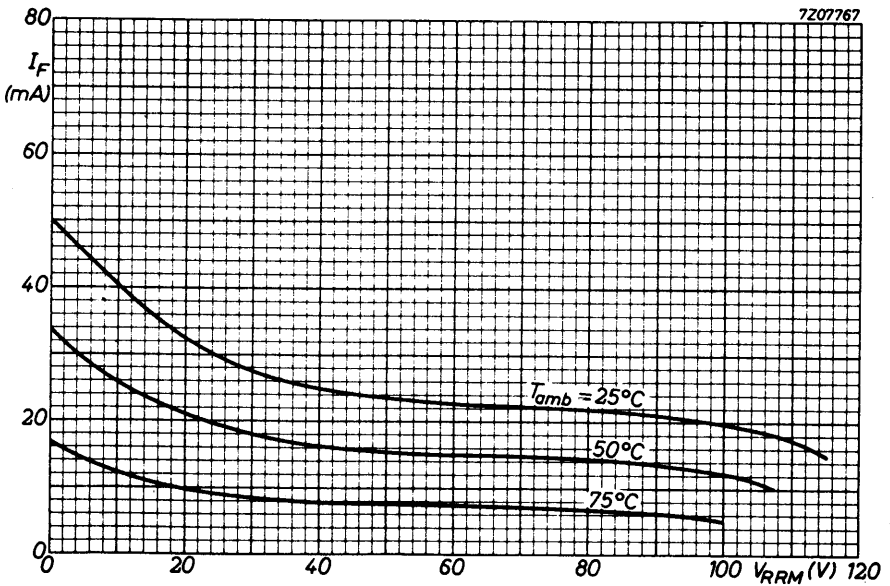
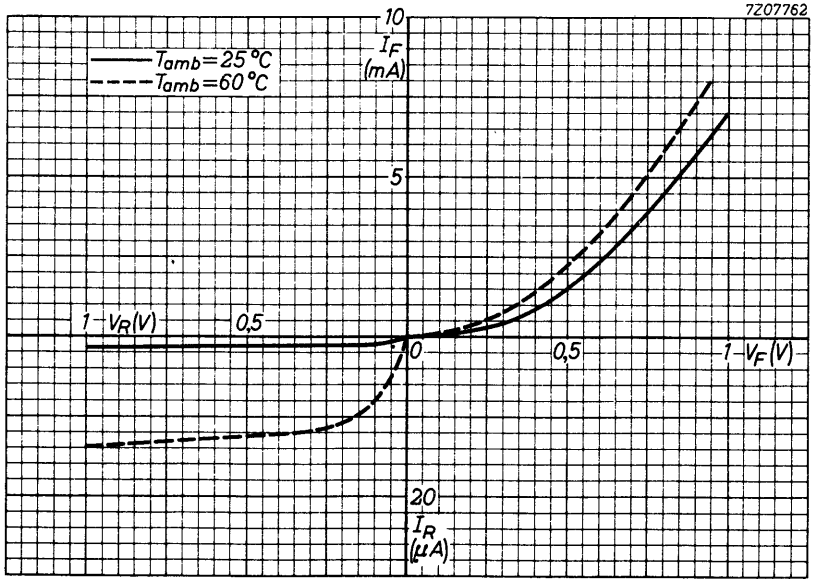

POINT CONTACT DIODE

Germanium diode in all-glass DO-7 envelope intended for general purposes.

QUICK REFERENCE DATA

Continuous reverse voltage	V_R	max.	90 V
Repetitive peak reverse voltage	V_{RRM}	max.	115 V
Forward current (d.c.)	I_F	max.	50 mA
Repetitive peak forward current	I_{FRM}	max.	150 mA
Operating ambient temperature	T_{amb}	max.	75 °C
Forward voltage at $I_F = 30$ mA	V_F	<	2,6 V

MECHANICAL DATA

Dimensions in mm

Fig. 1 DO-7.

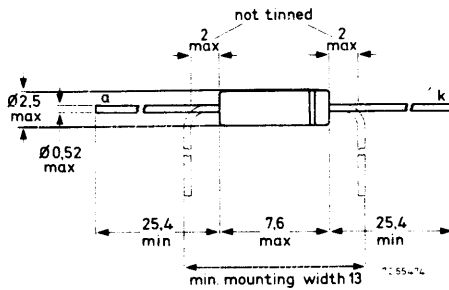

The diodes may be supplied either type-branded or with a broad *green* cathode band.

Available for current production only; not recommended for new designs.



RATINGS

Limiting values in accordance with the Absolute Maximum System (IEC 134)

Average reverse voltage (averaged over any 50 ms period)	V_R	max.	90 V
Repetitive peak reverse voltage	V_{RRM}	max.	115 V
Average forward current (averaged over any 50 ms period)	$I_F(AV)$	max.	50 mA
Repetitive peak forward current	I_{FRM}	max.	150 mA
Non-repetitive peak forward current ($t < 1$ s)	I_{FSM}	max.	500 mA
Storage temperature	T_{stg}		-65 to + 75 °C
Ambient temperature	T_{amb}		-55 to + 75 °C

THERMAL RESISTANCE

From junction to ambient in free air	$R_{th\ j-a}$	=	0,55 °C/mW
--------------------------------------	---------------	---	------------

CHARACTERISTICS

Forward voltage

$I_F = 0,1$ mA

$I_F = 10$ mA

$I_F = 30$ mA

Reverse current

$V_R = 1,5$ V

$V_R = 10$ V

$V_R = 75$ V

$V_R = 100$ V

	$T_{amb} = 25$ °C	$T_{amb} = 60$ °C
V_F	typ. 0,18 0,1 to 0,25	typ. 0,1 V 0,05 to 0,2 V
V_F	typ. 1,05 0,65 to 1,5	typ. 0,95 V 0,55 to 1,4 V
V_F	typ. 1,85 1,0 to 2,6	typ. 1,75 V 0,9 to 2,5 V
I_R	typ. 1,2 0,4 to 4,5	typ. 12 μ A 5,5 to 26 μ A
I_R	typ. 2,5 0,8 to 7	typ. 17 μ A 8 to 40 μ A
I_R	typ. 35 5,7 to 110	typ. 100 μ A 20 to 250 μ A
I_R	typ. 80 10 to 250	typ. 200 μ A 30 to 430 μ A

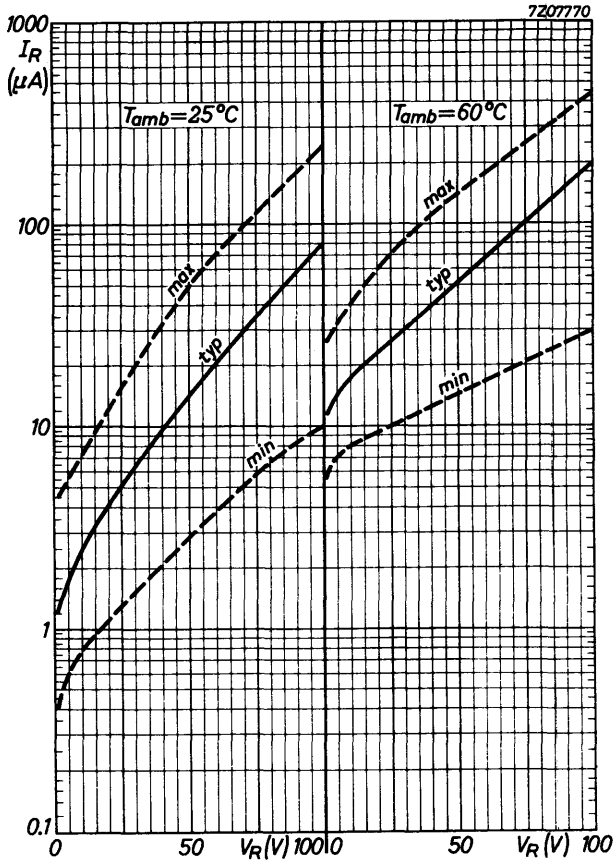

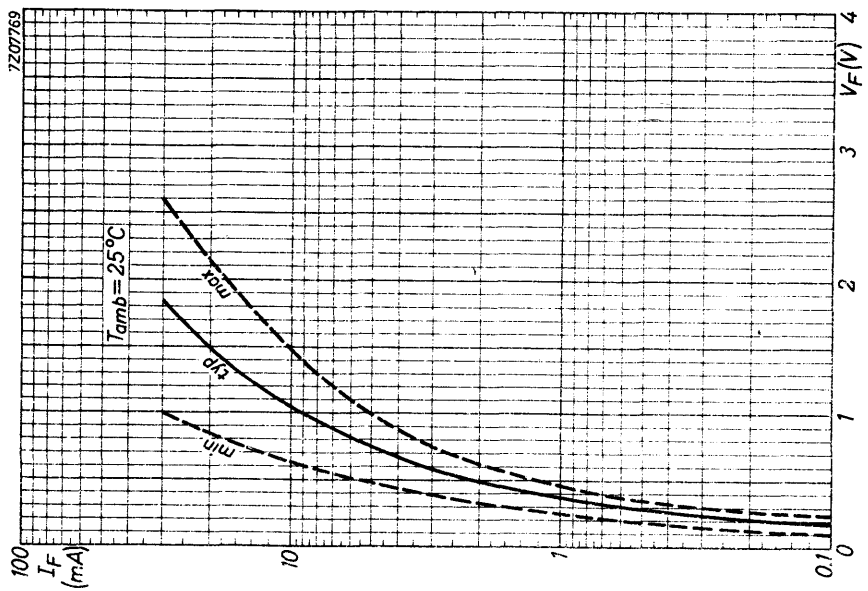
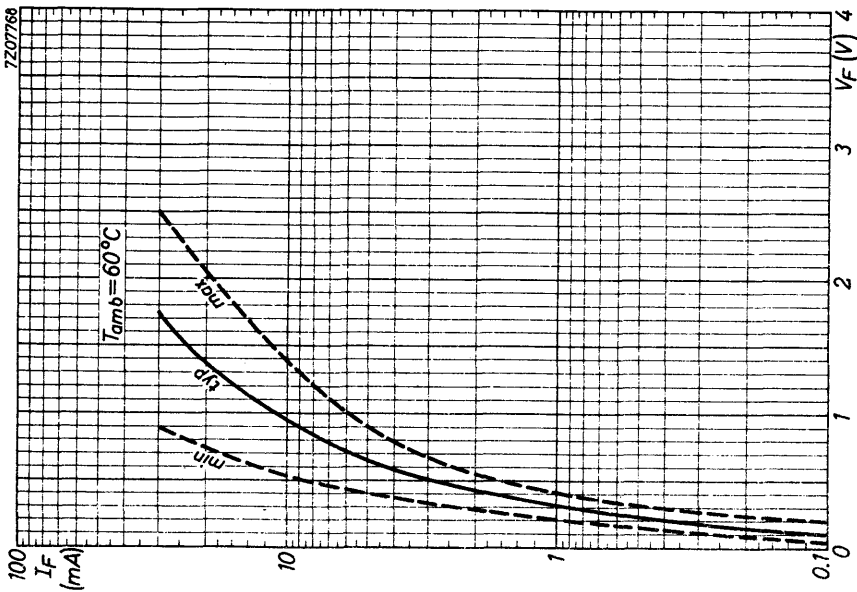

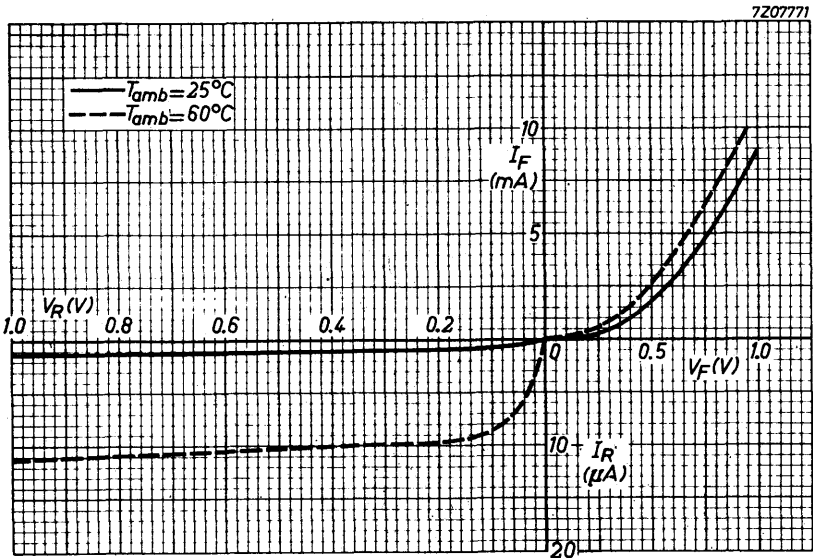

Fig. 5.

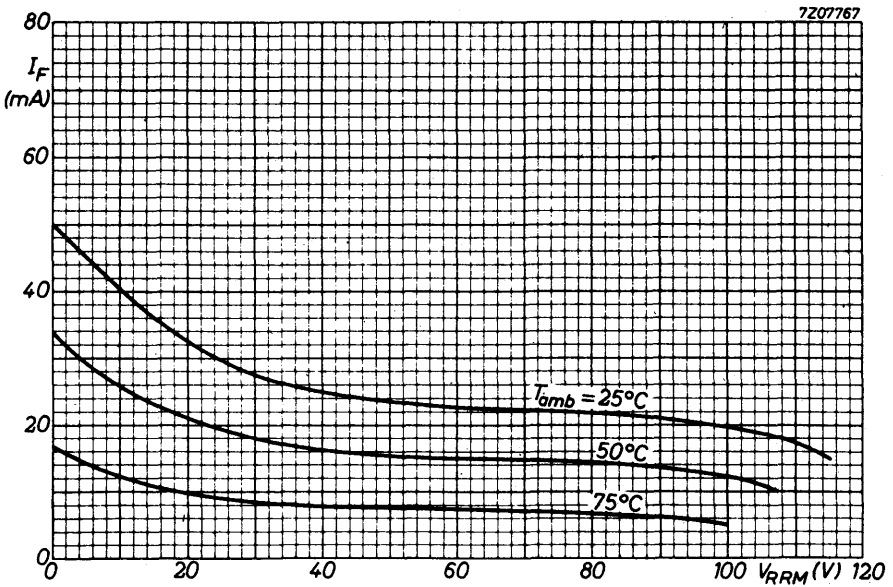

Fig. 6.

GOLD-BONDED DIODE

Gold-bonded germanium diode in all-glass construction for use in high-speed switching applications.

QUICK REFERENCE DATA

Continuous reverse voltage	V_R	max.	8 V
Average forward current	$I_{F(AV)}$	max.	20 mA
Repetitive peak forward current	I_{FRM}	max.	50 mA
Junction temperature	T_j	max.	85 °C
Forward voltage at $I_F = 30$ mA	V_F	<	1 V
Recovery charge when switched from $I_F = 10$ mA to $V_R = 5$ V	Q_s	<	30 pC

MECHANICAL DATA

Dimensions in mm

Fig. 1 DO-7.

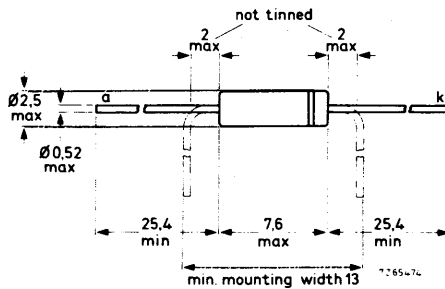

The diode is type-branded; the cathode being indicated by a coloured band.

Available for current production only; not recommended for new designs.



RATINGS

Limiting values in accordance with the **Absolute Maximum System** (IEC 134)

Continuous reverse voltage	V_R	max.	8 V
Average rectified forward current (averaged over any 50 ms period)	$I_F(AV)$	max.	30 mA
$T_{amb} = 25\text{ }^\circ\text{C}$	$I_F(AV)$	max.	20 mA
$T_{amb} = 60\text{ }^\circ\text{C}$			
Non-repetitive peak forward current ($t < 5\text{ ms}$)	I_{FSM}	max.	100 mA
$T_{amb} = 25\text{ }^\circ\text{C}$	I_{FSM}	max.	50 mA
$T_{amb} = 60\text{ }^\circ\text{C}$			
Storage temperature	T_{stg}		-65 to +75 $^\circ\text{C}$
Junction temperature	T_j	max.	75 $^\circ\text{C}$

THERMAL RESISTANCE

from junction to ambient in free air $R_{thj-a} = 0,55\text{ }^\circ\text{C/mW}$

CHARACTERISTICS

 $T_j = 25\text{ }^\circ\text{C}$, unless otherwise specified

		typ.	max.
Forward voltage	V_F	27	32 mV
$I_F = 0,1\text{ mA}$	V_F	500	600 mV
$I_F = 10\text{ mA}$	V_F	0,6	1,0 V
$I_F = 30\text{ mA}$			
Reverse current	I_R	5	25 μA
$V_R = 3\text{ V}$	I_R	30	85 μA
$V_R = 3\text{ V}; T_j = 60\text{ }^\circ\text{C}$	I_R	30	150 μA
$V_R = 8\text{ V}$	I_R	190	- μA
$V_R = 8\text{ V}; T_j = 60\text{ }^\circ\text{C}$			
Diode capacitance	C_d	3,3	- pF
$V_R = 1\text{ V}$	C_d	1,3	2 pF
$V_R = 3\text{ V}$			
Forward recovery voltage (see Fig. 4) measured at 10 mm from seal at $I_F = 20\text{ mA}; t_r = 5\text{ ns}$	V_{FR}	0,7	1,5 V
Recovery charge (see Fig. 2) when switched from $I_F = 10\text{ mA}$ to $V_R = 5\text{ V}; R_r = 500\text{ }\Omega; t_f \leq 5\text{ ns}$	Q_s	20	30 pC

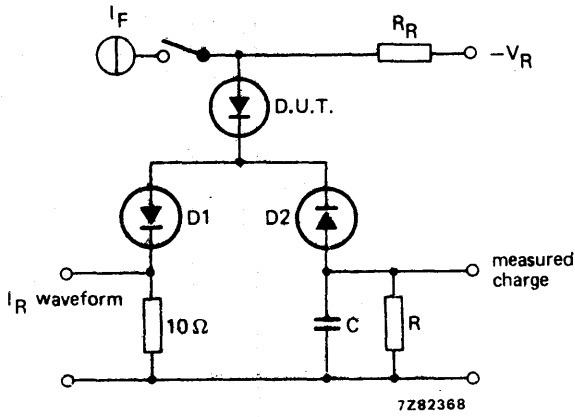

Fig. 2 Test circuit.

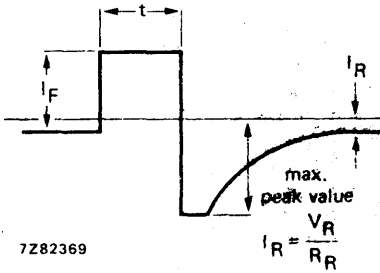

Fig. 3 Output waveform.

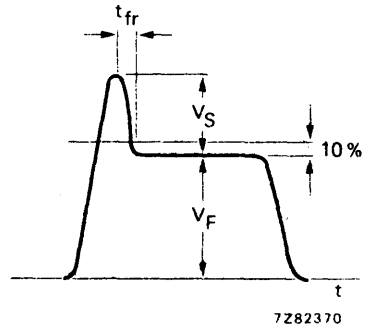

Fig. 4 Waveform.

Soldering instructions

Diodes may be soldered directly into the circuit but the heat conducted to the junction should be kept to a minimum by use of a thermal shunt.

Diodes may be dip-soldered at a solder temperature of 240 °C for a maximum of 10 seconds up to a point 5 mm from the seal.

Care should be taken not to bend the leads nearer than 1,5 mm from the seal.

Diodes are inherently sensitive to incident illumination, care should be taken to ensure that the external coating is not damaged.

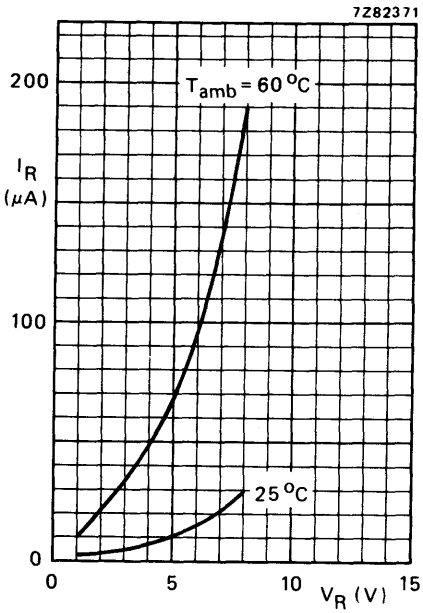

Fig. 5 Typical reverse current as a function of the reverse voltage.

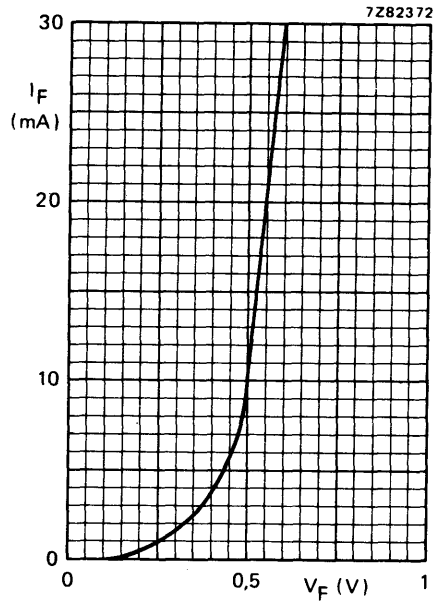

Fig. 6 Typical forward current as a function of the forward voltage.

GOLD BONDED DIODES

Germanium diodes in all-glass DO-7 envelope, intended for switching applications and general purposes.

QUICK REFERENCE DATA

		AAZ15	AAZ17
Continuous reverse voltage	V_R max.	75	50 V
Repetitive peak reverse voltage	V_{RRM} max.	100	75 V
Forward current (d.c.)	I_F max.	140	140 mA
Repetitive peak forward current	I_{FRM} max.	250	250 mA
Junction temperature	T_j max.	85	85 °C
Forward voltage at $I_F = 250$ mA	$V_F <$	1,1	1,1 V
Recovery charge when switched from $I_F = 10$ mA to $V_R = 10$ V	$Q_s <$	1800	900 pC

MECHANICAL DATA

Dimensions in mm

Fig. 1 DO-7.

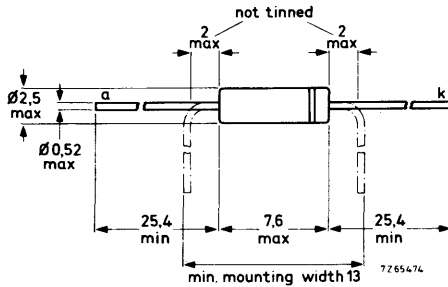

The diodes are type branded; the cathode being indicated by a coloured band.

Available for current production only; not recommended for new designs.



RATINGS Limiting values in accordance with the Absolute Maximum System (IEC134)

Voltages

		AAZ15	AAZ17
Continuous reverse voltage	V_R	max. 75	50 V
Repetitive peak reverse voltage	V_{RRM}	max. 100	75 V
Non-repetitive peak reverse voltage ($t < 1$ s)	V_{RSM}	max. 115	75 V

Currents

Forward current (d.c.)	I_F	max.	140 mA
Average rectified forward current (averaged over any 20 ms period)	$I_{F(AV)}$	max.	140 mA
Repetitive peak forward current	I_{FRM}	max.	250 mA
Non-repetitive peak forward current ($t < 1$ s)	I_{FSM}	max.	500 mA

Temperatures

Storage temperature	T_{stg}	-65 to +85	°C
Junction temperature	T_j	max. 85	°C

THERMAL RESISTANCE

From junction to ambient in free air	$R_{th j-a}$	=	0.55 °C/mW
--------------------------------------	--------------	---	------------

CHARACTERISTICS

Forward voltage at $T_j = 25\text{ }^\circ\text{C}$

$I_F = 0,1\text{ mA}$	$V_F < 0,20\text{ V}$
$I_F = 10\text{ mA}$	$V_F < 0,45\text{ V}$
$I_F = 250\text{ mA}$	$V_F < 1,10\text{ V}$

Forward voltage at $T_j = 60\text{ }^\circ\text{C}$

$I_F = 0,1\text{ mA}$	$V_F < 0,15\text{ V}$
$I_F = 10\text{ mA}$	$V_F < 0,40\text{ V}$
$I_F = 250\text{ mA}$	$V_F < 1,07\text{ V}$

Reverse current at $T_j = 25\text{ }^\circ\text{C}$

	AAZ15	AAZ17
$V_R = 1,5\text{ V}$	$I_R < 2,5$	$2,5\text{ }\mu\text{A}$
$V_R = 10\text{ V}$	$I_R < 4$	$15\text{ }\mu\text{A}$
$V_R = 50\text{ V}$	$I_R < 15$	$150\text{ }\mu\text{A}$
$V_R = 75\text{ V}$	$I_R < 25$	$300\text{ }\mu\text{A}$
$V_R = 100\text{ V}$	$I_R < 100$	$-\text{ }\mu\text{A}$

Reverse current at $T_j = 60\text{ }^\circ\text{C}$

$V_R = 1,5\text{ V}$	$I_R < 30$	$30\text{ }\mu\text{A}$
$V_R = 10\text{ V}$	$I_R < 40$	$60\text{ }\mu\text{A}$
$V_R = 50\text{ V}$	$I_R < 80$	$300\text{ }\mu\text{A}$
$V_R = 75\text{ V}$	$I_R < 120$	$500\text{ }\mu\text{A}$
$V_R = 100\text{ V}$	$I_R < 300$	$-\text{ }\mu\text{A}$

Diode capacitance at $T_j = 25\text{ }^\circ\text{C}$

$V_R = 1\text{ V}; f = 1\text{ MHz}$	$C_d < 2$	2 pF
--------------------------------------	-----------	---------------

CHARACTERISTICS (continued)

$T_j = 25\text{ }^\circ\text{C}$

Reverse recovery time when switched from

$I_F = 10\text{ mA}$ to $I_R = 10\text{ mA}$; $R_L = 100\text{ }\Omega$;

measured at $I_R = 1\text{ mA}$

AAZ15	t_{RR}	typ.	350	ns
AAZ17	t_{RR}	<	350	ns

Test circuit and waveforms :

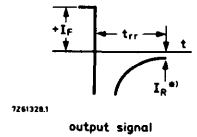
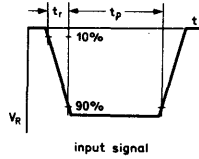
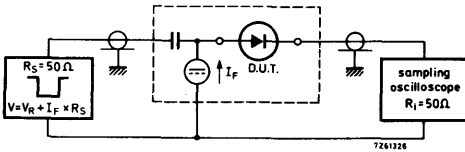

Input signal : Rise time of the reverse pulse
Reverse pulse duration
Duty factor

$t_r = 0,6\text{ ns}$

*) $I_R = 1\text{ mA}$

$t_p = 500\text{ ns}$

$\delta = 0,05$

Oscilloscope : Rise time

$t_r = 0,35\text{ ns}$

Circuit capacitance $C \leq 1\text{ pF}$ ($C =$ oscilloscope input capacitance + parasitic capacitance)

Recovery charge when switched from

$I_F = 10\text{ mA}$ to $V_R = 10\text{ V}$; $R_L = 1\text{ k}\Omega$

AAZ15	Q_S	<	1800	pC
AAZ17	Q_S	<	900	pC

Test circuit and waveform :

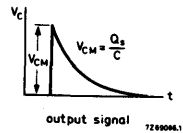
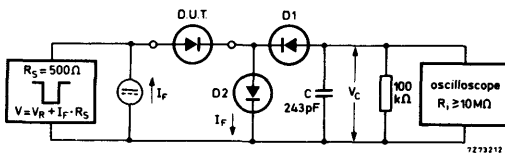

$D1 = D2 = \text{BAW62}$

Input signal : Rise time of the reverse pulse

$t_r = 2\text{ ns}$

Reverse pulse duration

$t_p = 400\text{ ns}$

Duty factor

$\delta = 0,02$

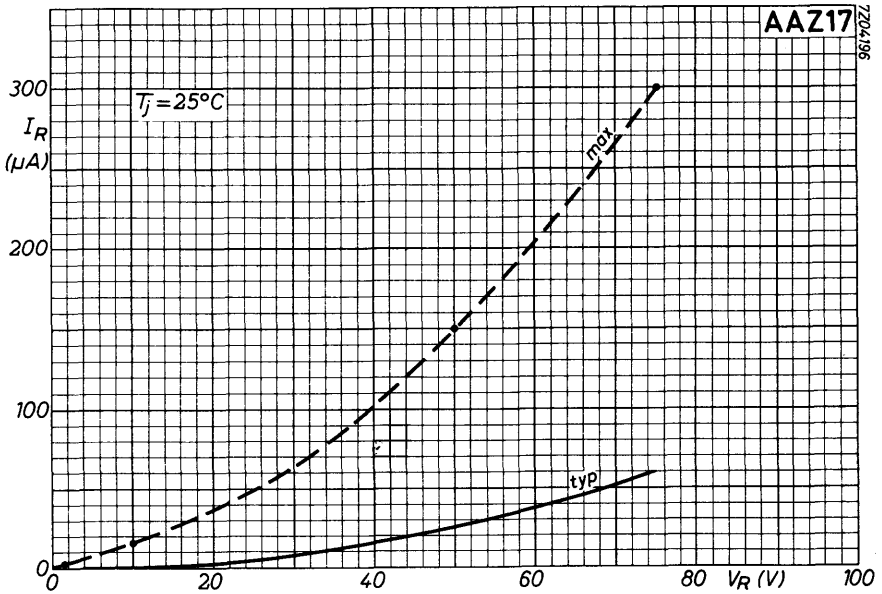
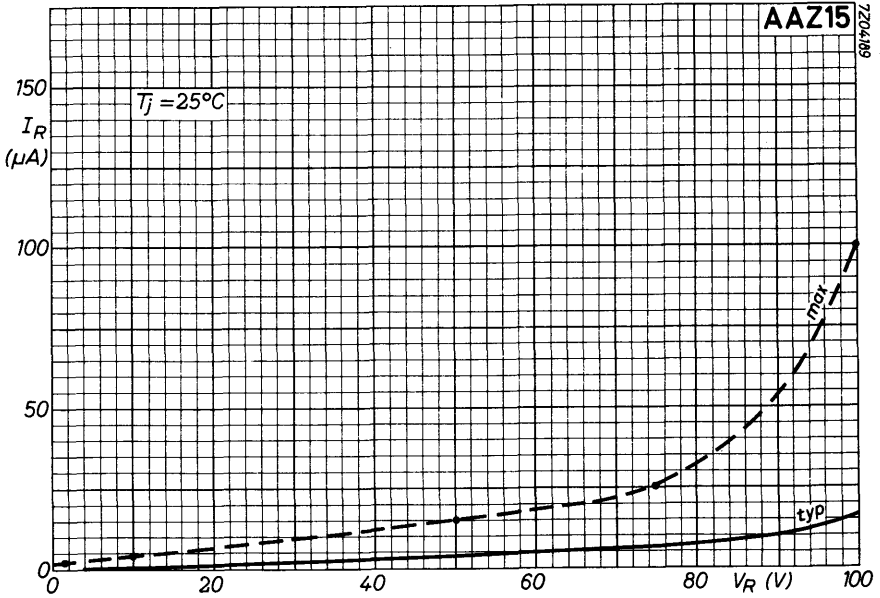

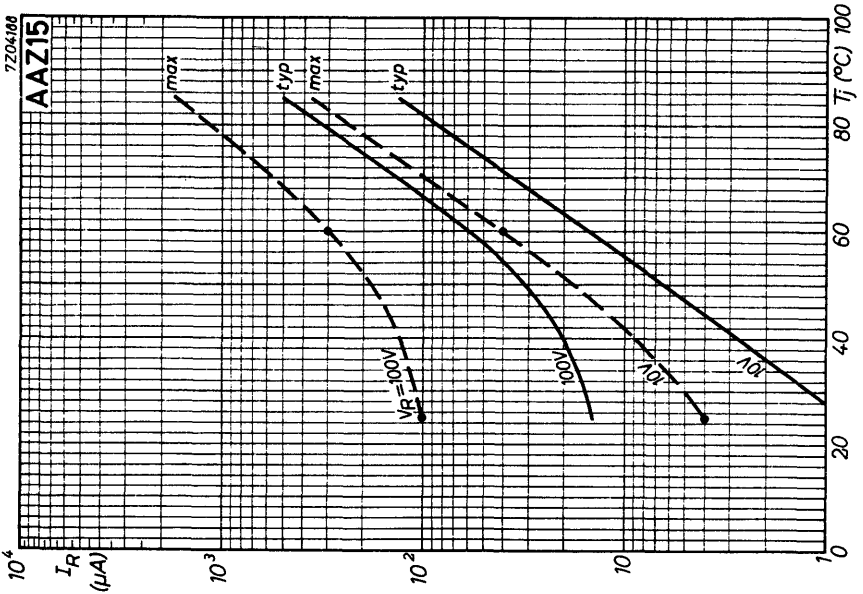
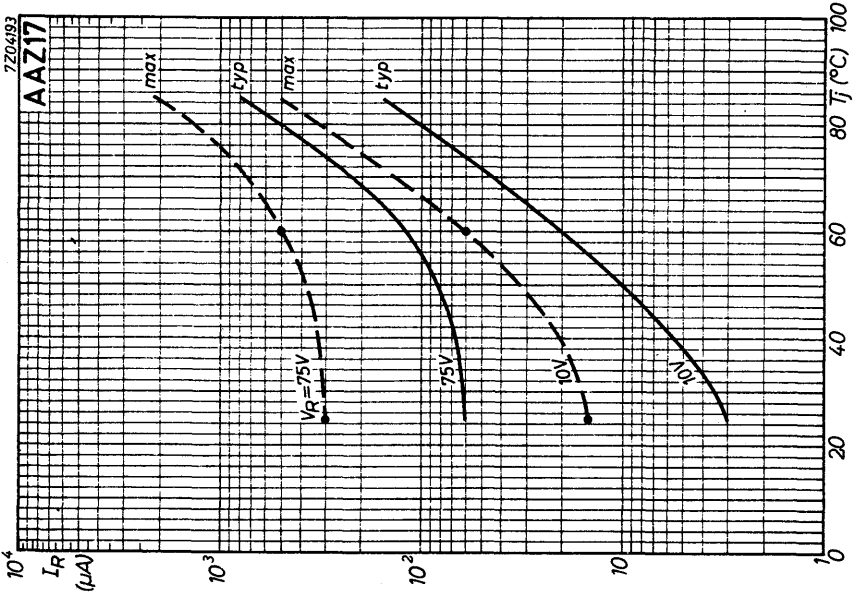

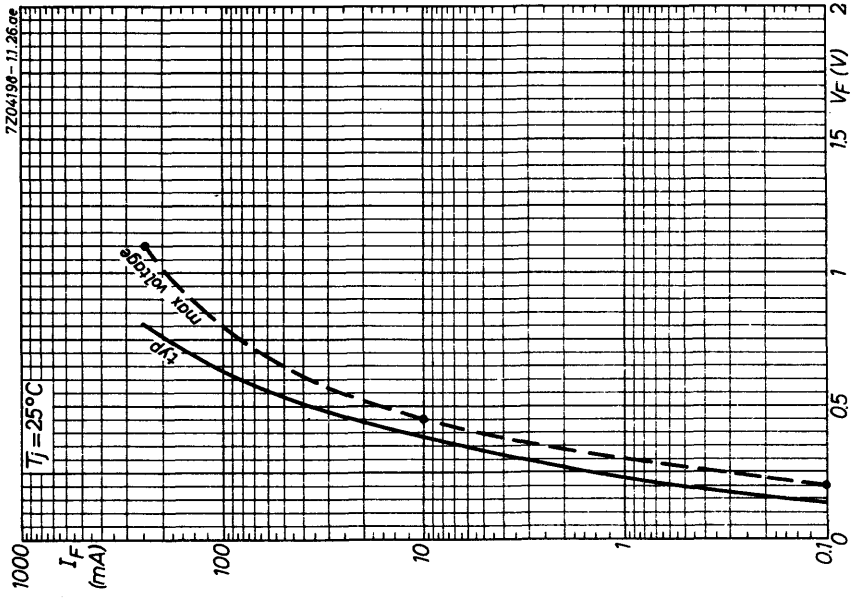

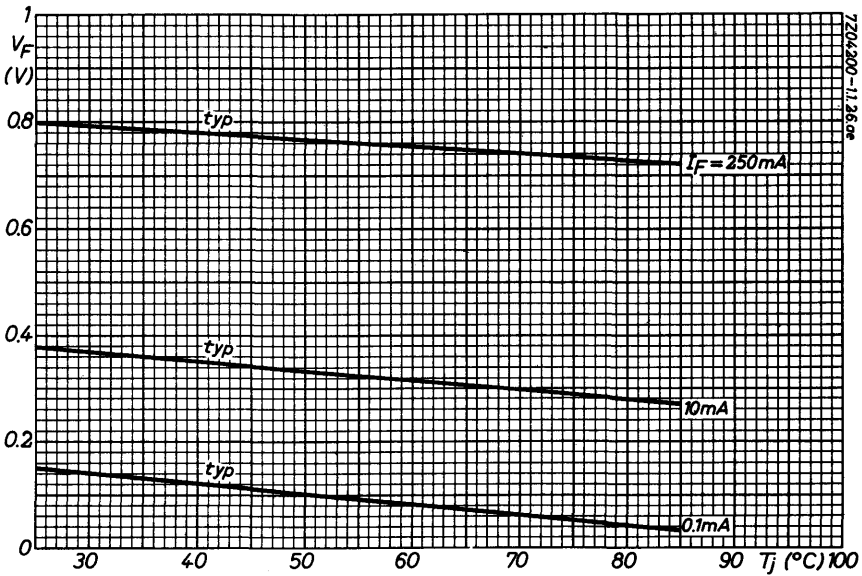
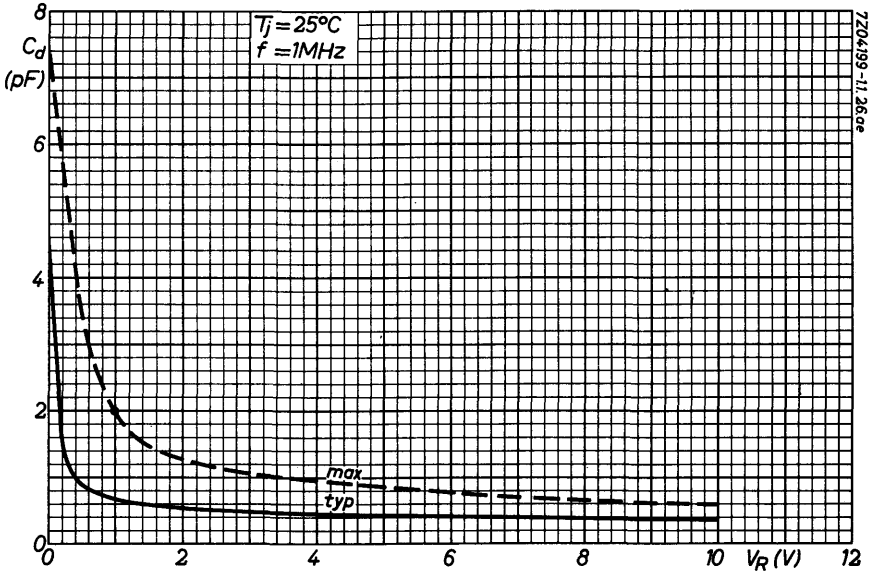

7204190.1

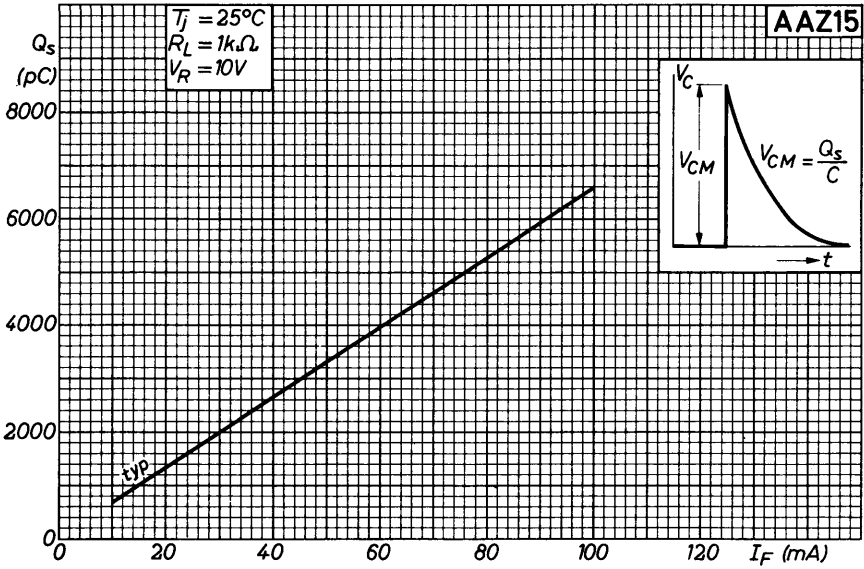

7204197.1

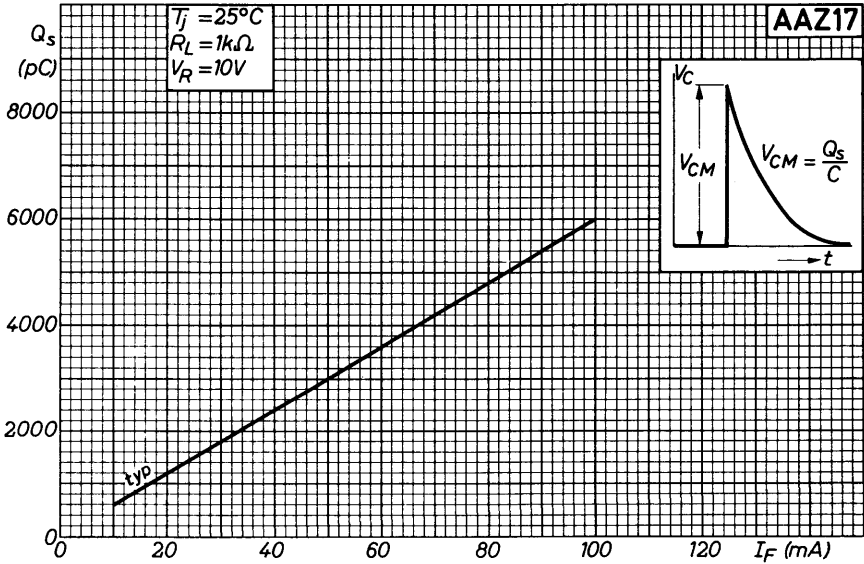

AAZ15
AAZ17

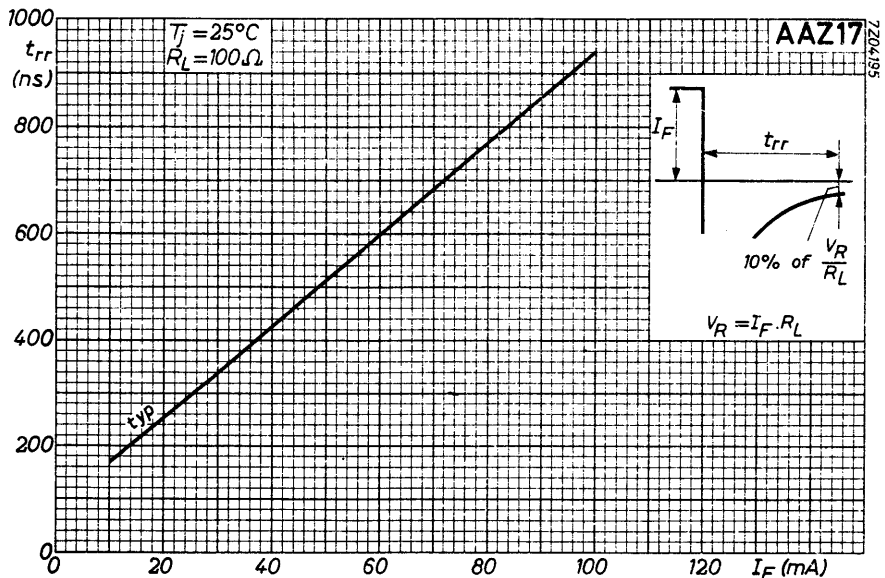
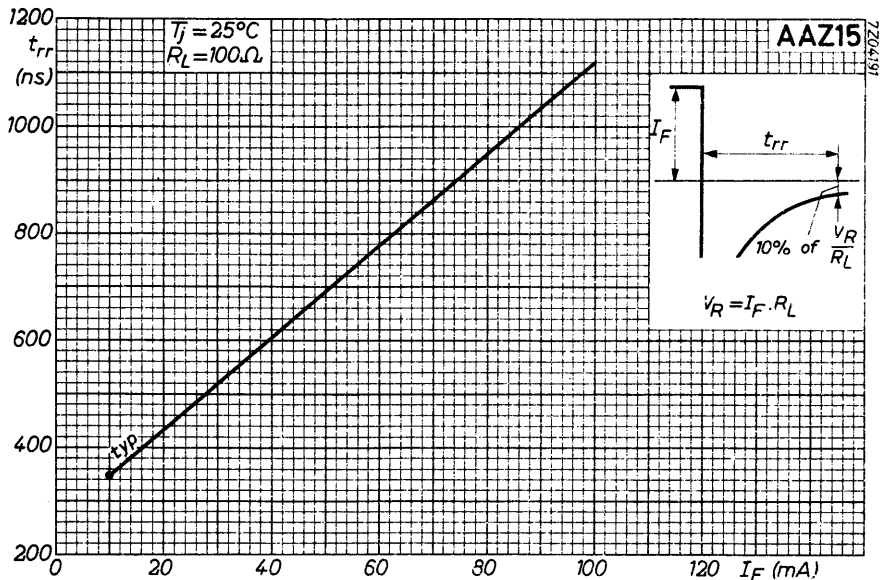

7204192.1

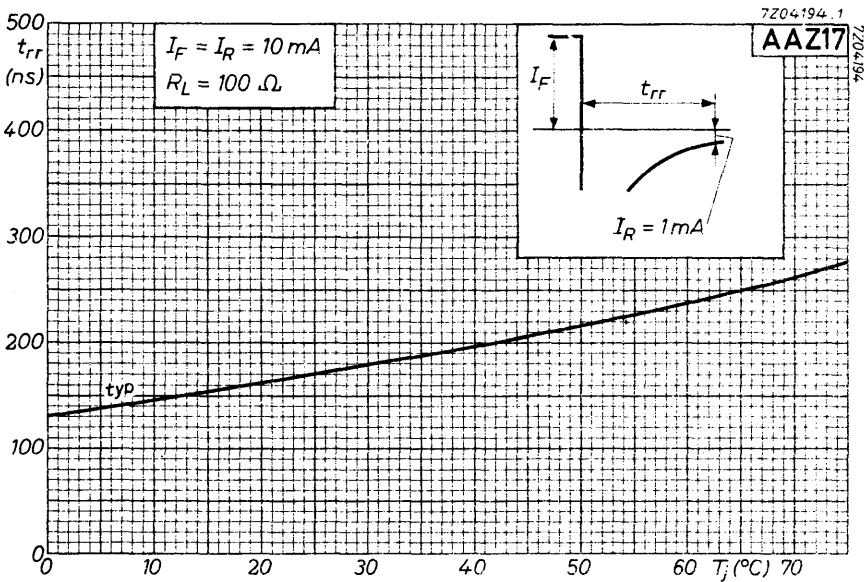
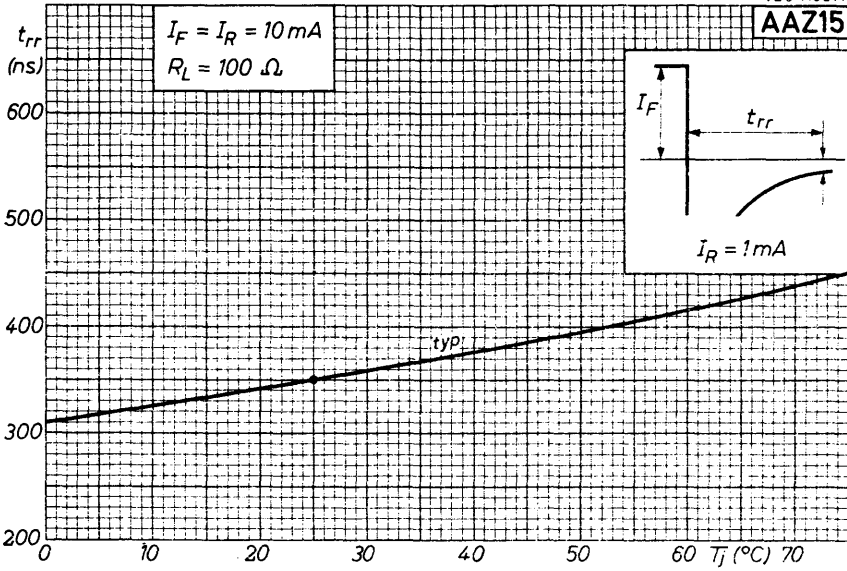

GOLD BONDED DIODE

Germanium diode in all-glass DO-7 envelope, intended for switching applications and general purposes.

QUICK REFERENCE DATA

Continuous reverse voltage	V_R	max.	25 V
Repetitive peak reverse voltage	V_{RRM}	max.	25 V
Forward current (d.c.)	I_F	max.	110 mA
Repetitive peak forward current	I_{FRM}	max.	150 mA
Junction temperature	T_j	max.	75 °C
Forward voltage at $I_F = 150$ mA	V_F	<	1,1 V
Recovery charge when switched from $I_F = 10$ mA to $V_R = 10$ V	Q_S	<	600 pC

MECHANICAL DATA

Dimensions in mm

Fig. 1 DO-7.

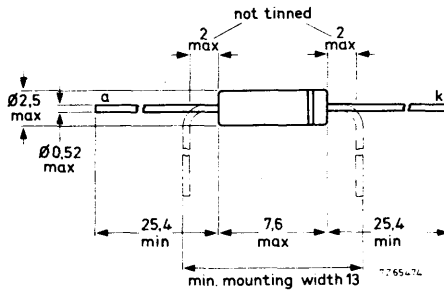

The diodes are type-branded; the cathode being indicated by a coloured band.

Available for current production only; not recommended for new designs.



RATINGS Limiting values in accordance with the Absolute Maximum System (IEC134)

Voltages

Continuous reverse voltage	V_R	max.	25 V
Repetitive peak reverse voltage	V_{RRM}	max.	25 V
Non-repetitive peak reverse voltage ($t < 1$ s)	V_{RSM}	max.	30 V

Currents

Forward current (d.c.)	I_F	max.	110 mA
Average rectified forward current (averaged over any 20 ms period)	$I_{F(AV)}$	max.	110 mA
Repetitive peak forward current	I_{FRM}	max.	150 mA
Non-repetitive peak forward current ($t < 1$ s)	I_{FSM}	max.	200 mA

Temperatures

Storage temperature	T_{stg}	-65 to +75	$^{\circ}C$
Junction temperature	T_j	max.	75 $^{\circ}C$

THERMAL RESISTANCE

From junction to ambient in free air	$R_{th\ j-a}$	=	0.55 $^{\circ}C/mW$
--------------------------------------	---------------	---	---------------------

CHARACTERISTICS

Forward voltage at $T_j = 25\text{ }^\circ\text{C}$

$I_F = 0,1\text{ mA}$	$V_F < 0,20\text{ V}$
$I_F = 1,0\text{ mA}$	$V_F < 0,31\text{ V}$
$I_F = 10\text{ mA}$	$V_F < 0,45\text{ V}$
$I_F = 30\text{ mA}$	$V_F < 0,65\text{ V}$
$I_F = 150\text{ mA}$	$V_F < 1,10\text{ V}$

Forward voltage at $T_j = 60\text{ }^\circ\text{C}$

$I_F = 0,1\text{ mA}$	$V_F < 0,14\text{ V}$
$I_F = 1,0\text{ mA}$	$V_F < 0,28\text{ V}$
$I_F = 10\text{ mA}$	$V_F < 0,43\text{ V}$
$I_F = 30\text{ mA}$	$V_F < 0,62\text{ V}$
$I_F = 150\text{ mA}$	$V_F < 1,10\text{ V}$

Reverse current at $T_j = 25\text{ }^\circ\text{C}$

$V_R = 1,5\text{ V}$	$I_R < 3,5\text{ }\mu\text{A}$
$V_R = 10\text{ V}$	$I_R < 15\text{ }\mu\text{A}$
$V_R = 20\text{ V}$	$I_R < 50\text{ }\mu\text{A}$
$V_R = 25\text{ V}$	$I_R < 100\text{ }\mu\text{A}$

Reverse current at $T_j = 60\text{ }^\circ\text{C}$

$V_R = 1,5\text{ V}$	$I_R < 20\text{ }\mu\text{A}$
$V_R = 10\text{ V}$	$I_R < 40\text{ }\mu\text{A}$
$V_R = 20\text{ V}$	$I_R < 90\text{ }\mu\text{A}$
$V_R = 25\text{ V}$	$I_R < 160\text{ }\mu\text{A}$

Diode capacitance at $T_j = 25\text{ }^\circ\text{C}$

$V_R = 1\text{ V}; f = 1\text{ MHz}$	$C_d < 3,5\text{ pF}$
--------------------------------------	-----------------------



CHARACTERISTICS (continued)

$T_j = 25\text{ }^\circ\text{C}$

Reverse recovery time when switched from

$I_F = 10\text{ mA}$ to $I_R = 10\text{ mA}$; $R_L = 100\text{ }\Omega$;
measured at $I_R = 1\text{ mA}$

$t_{rr} < 70\text{ ns}$

Test circuit and waveforms :

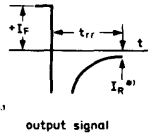
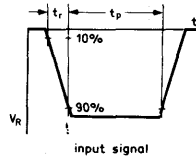
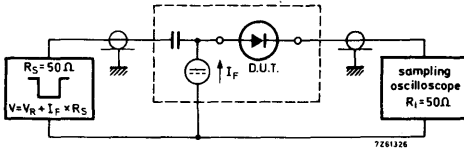

Input signal : Rise time of the reverse pulse
Reverse pulse duration
Duty factor

$t_r = 0,6\text{ ns}$
 $t_p = 100\text{ ns}$
 $\delta = 0,05$

*) $I_R = 1\text{ mA}$

Oscilloscope : Rise time

$t_r = 0,35\text{ ns}$

Circuit capacitance $C \leq 1\text{ pF}$ ($C =$ oscilloscope input capacitance + parasitic capacitance)

Recovery charge when switched from

$I_F = 10\text{ mA}$ to $V_R = 10\text{ V}$; $R_L = 1\text{ k}\Omega$

$Q_S < 600\text{ pC}$

Test circuit and waveform :

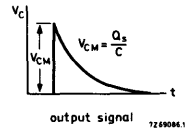
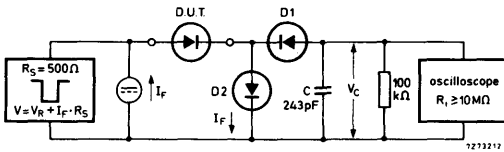

$D1 = D2 = \text{BAW62}$

Input signal : Rise time of the reverse pulse
Reverse pulse duration
Duty factor

$t_r = 2\text{ ns}$
 $t_p = 400\text{ ns}$
 $\delta = 0,02$

TUNER DIODES

G 



SILICON PLANAR DIODE

The BA182 is a switching diode in a plastic envelope. It is intended for band switching in v.h.f. television tuners.

QUICK REFERENCE DATA			
Continuous reverse voltage	V_R	max.	35 V
Forward current (d. c.)	I_F	max.	100 mA
Junction temperature	T_j	max.	100 °C
Diode capacitance at $f = 1$ MHz $V_R = 20$ V	C_d	typ. <	0,8 pF 1,0 pF
Series resistance at $f = 200$ MHz $I_F = 5$ mA	r_D	typ. <	0,5 Ω 0,7 Ω

MECHANICAL DATA

Dimensions in mm

SOD-23

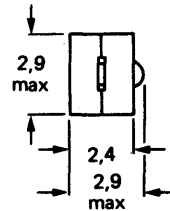
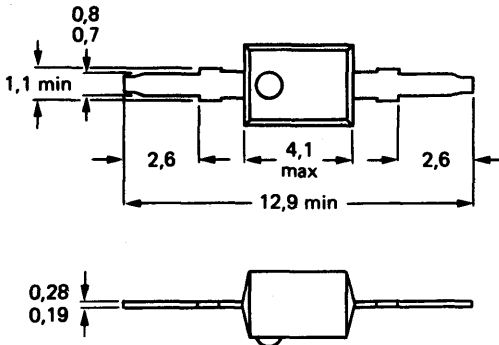

7Z61372.3

The blue band indicates the cathode

The sealing of the plastic envelope withstands the accelerated damp heat test of IEC recommendation 68 - 2 (test D, severity IV, 6 cycles).

Available for current production only, not recommended for new designs.



RATINGS (Limiting values) ¹⁾

Voltage

Continuous reverse voltage V_R max. 35 V

Current

Forward current (d.c.) I_F max. 100 mA

Temperatures

Storage temperature T_{stg} -55 to +100 °C

Junction temperature T_j max. 100 °C

THERMAL RESISTANCE

From junction to ambient in free air $R_{th\ j-a}$ = 0.4 °C/mW

CHARACTERISTICS

Forward voltage at $I_F = 100$ mA V_F < 1.2 V

Reverse current

$V_R = 20$ V I_R < 100 nA

$V_R = 20$ V; $T_j = 60$ °C I_R < 1 μA

Diode capacitance at $f = 1$ MHz

$V_R = 20$ V C_d typ. 0.8 pF

< 1 pF

Series resistance at $f = 200$ MHz

$I_F = 5$ mA r_D typ. 0.5 Ω

< 0.7 Ω

¹⁾ Limiting values according to the Absolute Maximum System as defined in IEC publication 134.

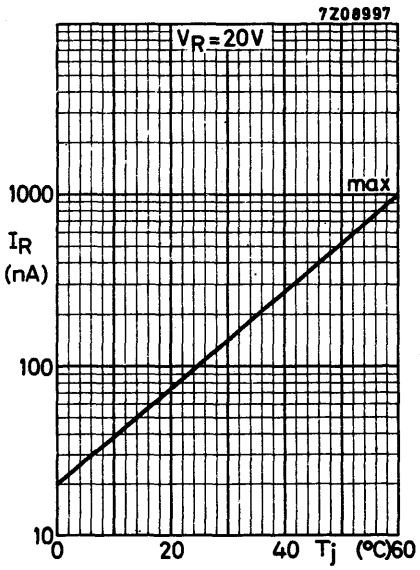
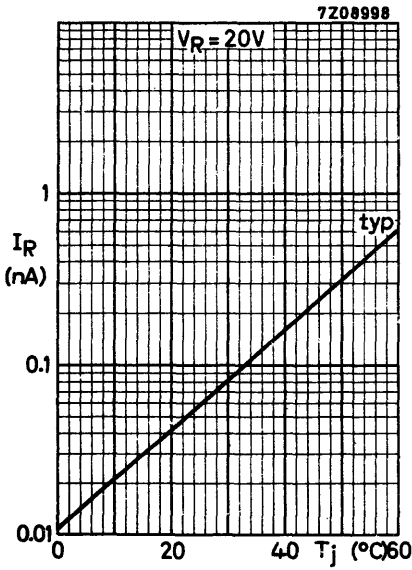
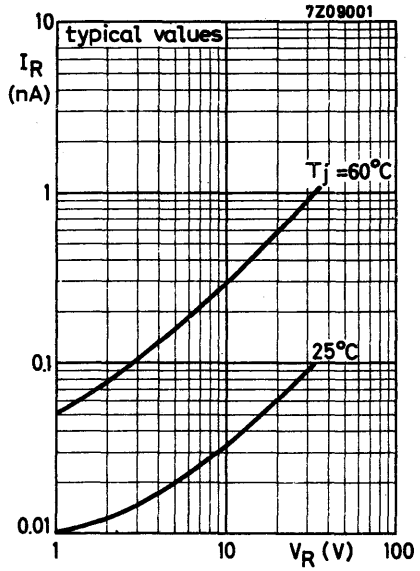
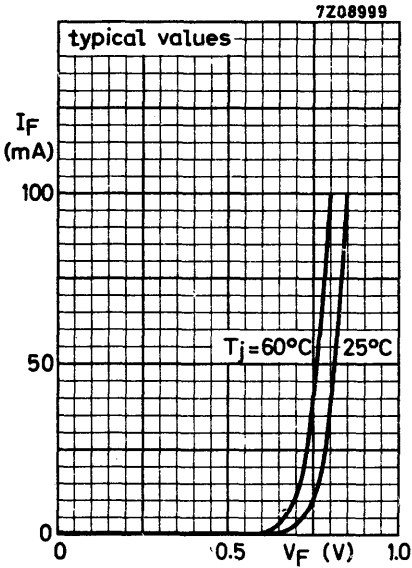

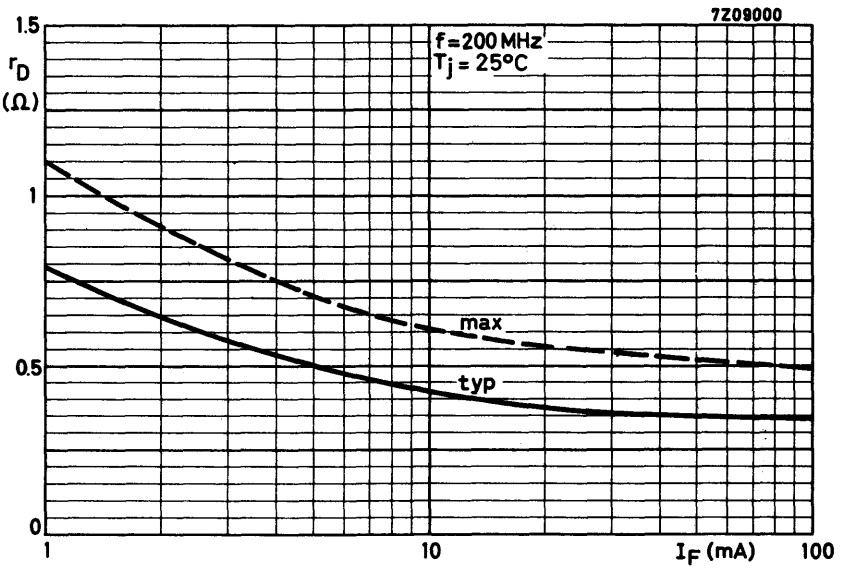
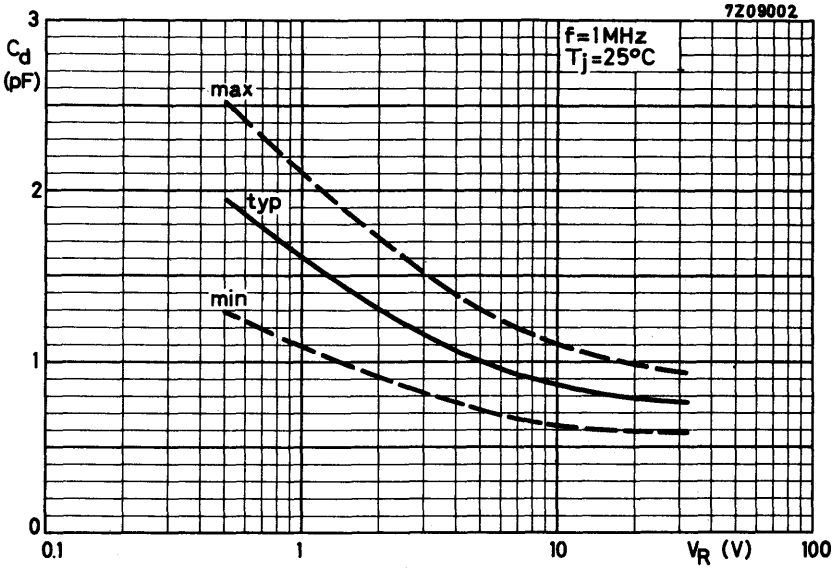

SILICON A.M. BAND SWITCHING DIODE

The BA223 is a switching diode in whiskerless glass DO-35 construction. It is intended for band switching in a.m. radio receivers.

QUICK REFERENCE DATA

Continuous reverse voltage	V_R	max.	20 V
Forward current (d.c.)	I_F	max.	50 mA
Junction temperature	T_j	max.	150 °C
Diode capacitance at $f = 1$ MHz $V_R = 6$ V	C_d	<	3,5 pF
Series resistance at $f = 1$ MHz $I_F = 10$ mA	r_D	<	1,5 Ω

MECHANICAL DATA

Dimensions in mm

Fig. 1 DO-35 (SOD-27).

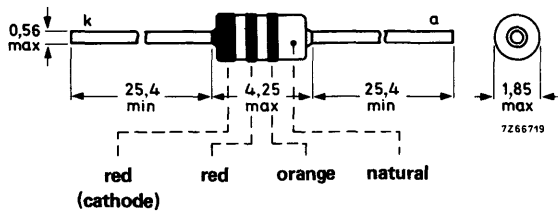

The diodes may be either type-branded or colour-coded.

RATINGS

Limiting values in accordance with the Absolute Maximum System (IEC 134)

Continuous reverse voltage	V_R	max.	20 V
Forward current (d.c.)	I_F	max.	50 mA
Storage temperature	T_{stg}		-55 to +150 °C
Junction temperature	T_j	max.	150 °C

THERMAL RESISTANCE

From junction to ambient in free air	$R_{th\ j-a}$	=	0,5 °C/mW
--------------------------------------	---------------	---	-----------

CHARACTERISTICS $T_j = 25\text{ °C}$ unless otherwise specified

Forward voltage $I_F = 50\text{ mA}$	V_F	<	1,0 V
Reverse current $V_R = 20\text{ V}$	I_R	<	100 nA
$V_R = 20\text{ V}; T_j = 125\text{ °C}$	I_R	<	20 μA
Diode capacitance at $f = 1\text{ MHz}$ $V_R = 6\text{ V}$	C_d	<	3,5 pF
Series resistance at $f = 1\text{ MHz}$ $I_F = 10\text{ mA}$	r_D	<	1,5 Ω



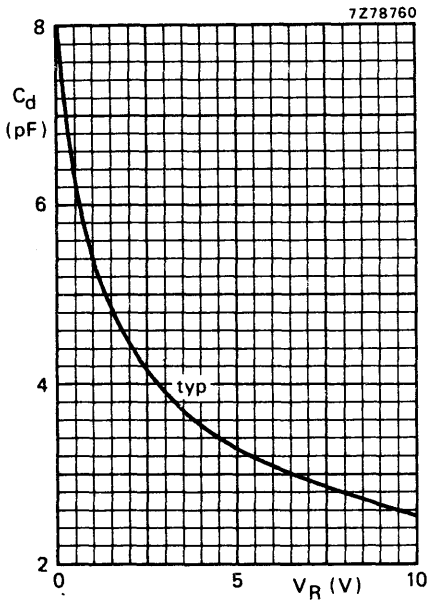

Fig. 2 $f = 1$ MHz; $T_j = 25$ °C.

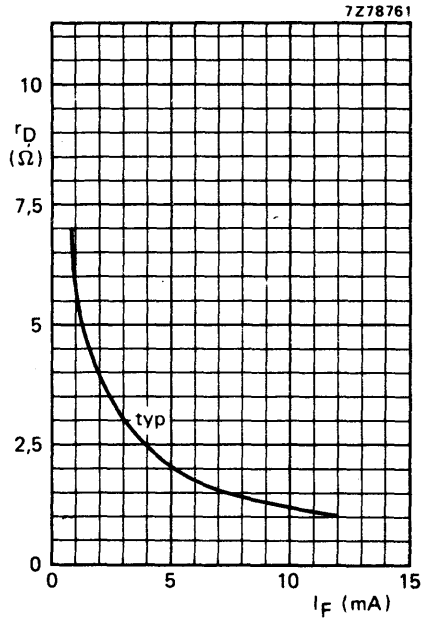

Fig. 3 $f = 1$ MHz; $T_j = 25$ °C.

SILICON PLANAR DIODES

Switching diodes in a DO-35 envelope, intended for band switching in v. h. f. television tuners.

QUICK REFERENCE DATA				
Continuous reverse voltage	V_R	max.	20	V
Forward current (d. c.)	I_F	max.	100	mA
Junction temperature	T_j	max.	150	°C
Diode capacitance at $f = 1$ to 100 MHz $V_R = 15$ V	C_d	typ.	1,1	pF
		<	2	pF
Series resistance at $f = 200$ MHz $I_F = 10$ mA	r_D	typ	0,7	Ω
		<	1	Ω
			BA243	BA244
			0,4	0,5
			Ω	Ω

MECHANICAL DATA

Dimensions in mm

DO-35

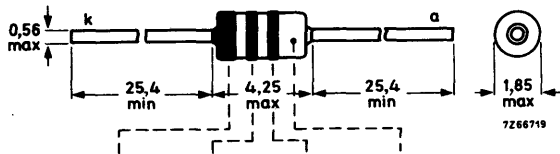

BA243: red yellow orange natural
 (cathode)

BA244: red yellow yellow natural
 (cathode)

The diodes may be either type-branded or colour-coded.

RATINGS Limiting values in accordance with the Absolute Maximum System (IEC 134)

Voltage

Continuous reverse voltage V_R max. 20 V

Current

Forward current (d. c.) I_F max. 100 mA

Temperatures

Storage temperature T_{stg} -55 to +150 °C

Junction temperature T_j max. 150 °C

THERMAL RESISTANCE

From junction to ambient in free air $R_{th\ j-a}$ = 0,6 °C/mW

CHARACTERISTICS

$T_j = 25$ °C unless otherwise specified

Forward voltage at $I_F = 100$ mA V_F < 1 V

Reverse current at $V_R = 15$ V I_R < 100 nA

$V_R = 15$ V; $T_{amb} = 60$ °C I_R < 1 μA

Diode capacitance at $f = 1$ to 100 MHz

$V_R = 15$ V C_d typ. 1,1 pF
< 2 pF

Relative capacitance variation

due to reverse voltage variation
at $V_R = 7$ to 20 V; $f = 1$ to 100 MHz
related to $V_R = 7$ V

$\frac{\Delta C_d}{C_d \cdot \Delta V_R}$ typ. 1 %/V

Series resistance at $f = 200$ MHz

$I_F = 10$ mA

	BA243	BA244
r_D typ.	0,7	0,4 Ω
<	1	0,5 Ω

Relative series resistance variation

due to forward current variation
at $I_F = 2$ to 40 mA; $f = 200$ MHz
related to $I_F = 2$ mA

$\frac{\Delta r_D}{r_D \cdot \Delta I_F}$ typ. 2 %/mA

Series inductance (measured on envelope)

L_s typ. 2,5 nH

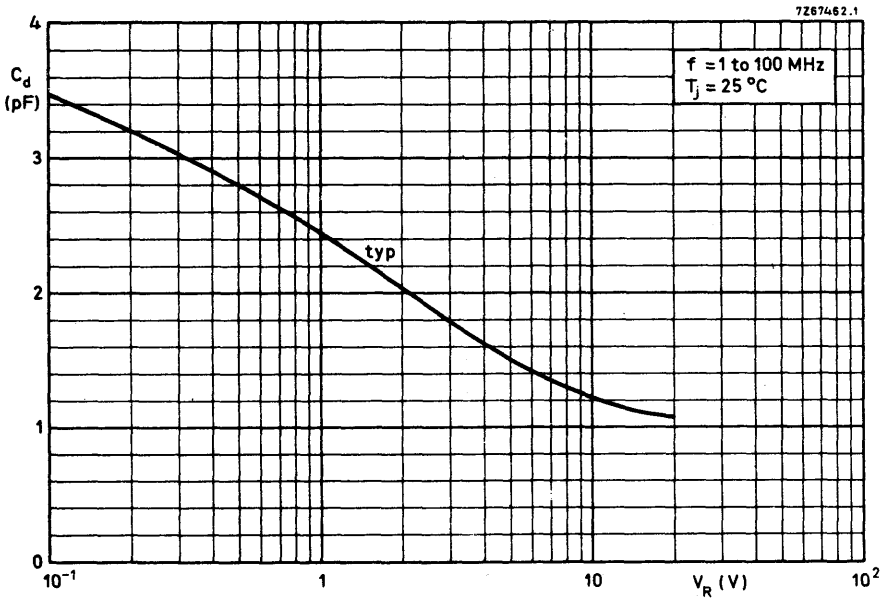
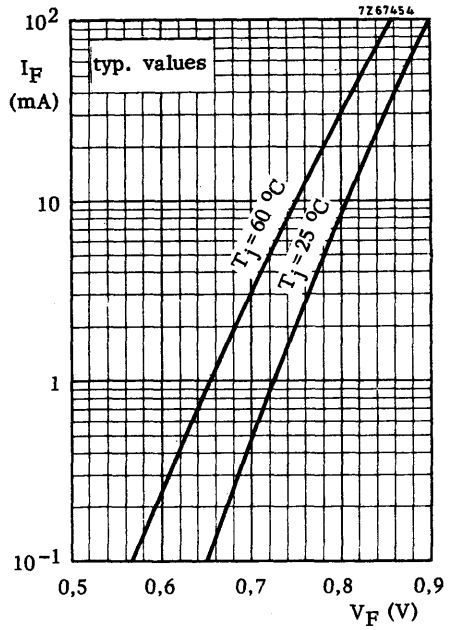
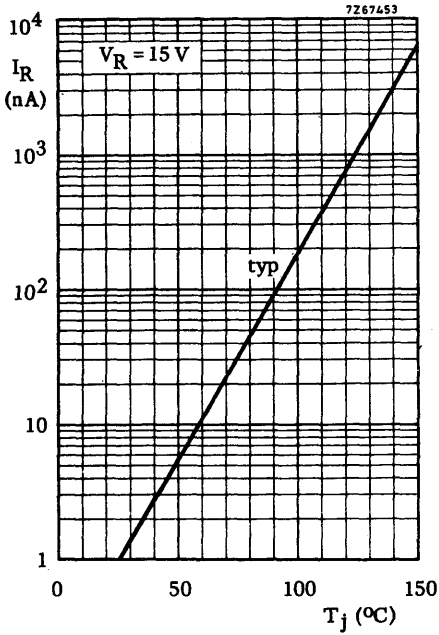

BA243
BA244

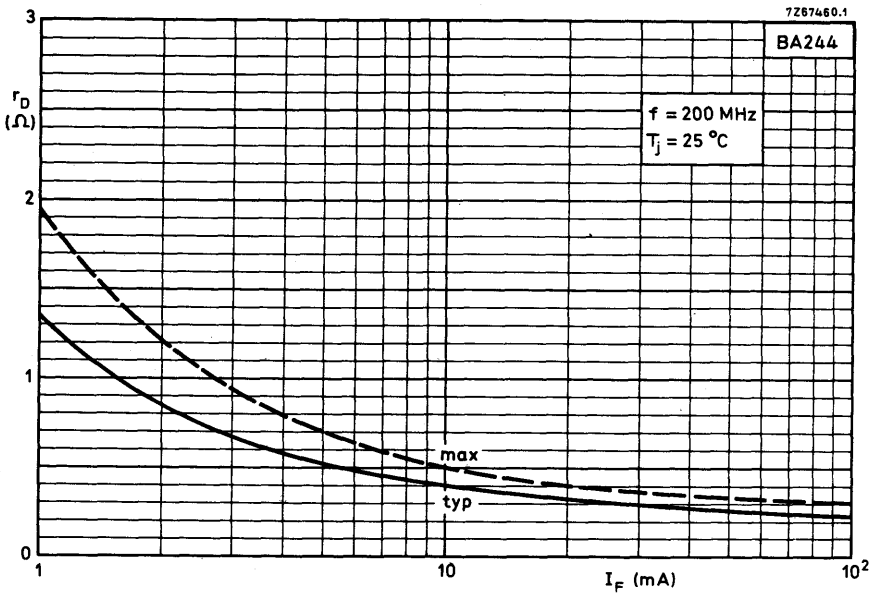
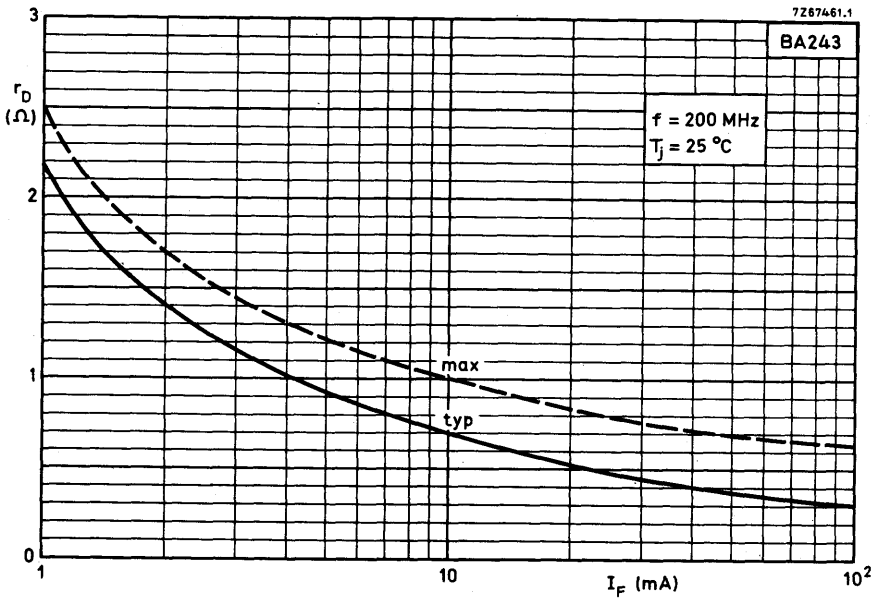

U.H.F. MIXER DIODE

Silicon epitaxial Schottky barrier diode in a plastic envelope intended for mixer applications in u. h. f. tuners.

QUICK REFERENCE DATA			
Continuous reverse voltage	V_R	max. 4	V
Forward current (d. c.)	I_F	max. 30	mA
Junction temperature	T_j	max. 100	°C
Noise figure at $f = 900$ MHz	F	< 8	dB

MECHANICAL DATA

Dimensions in mm

SOD-23

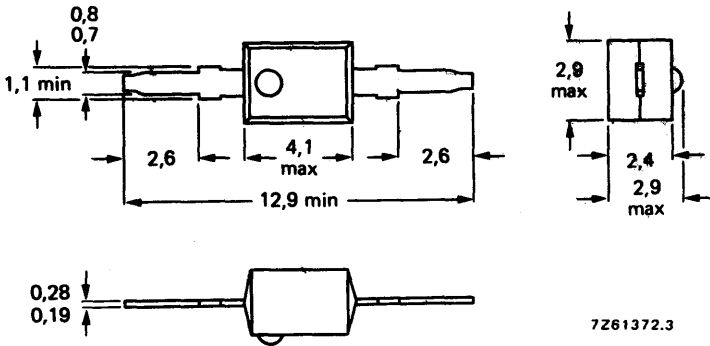

The orange band indicates the cathode

The sealing of the plastic envelope withstands the accelerated damp heat test of IEC recommendation 68-2 (test D, severity IV, 6 cycles).



RATINGS Limiting values in accordance with the Absolute Maximum System (IEC 134)

Voltage

Continuous reverse voltage V_R max. 4 V

Current

Forward current (d. c.) I_F max. 30 mA

Temperatures

Storage temperature T_{stg} -65 to +100 °C

Junction temperature T_j max. 100 °C

THERMAL RESISTANCE

From junction to ambient in free air $R_{th\ j-a} = 0,25$ °C/mW

CHARACTERISTICS

$T_{amb} = 25$ °C unless otherwise specified

Reverse current

$V_R = 3$ V $I_R < 0,25$ μA

$V_R = 3$ V; $T_{amb} = 60$ °C $I_R < 1,25$ μA

Forward voltage

$I_F = 10$ mA $V_F < 600$ mV

Series resistance at $f = 1$ kHz

$I_F = 5$ mA $r_D < 15$ Ω

Diode capacitance

$V_R = 0$; $f = 1$ MHz $C_d < 1,0$ pF

Noise figure at $f = 900$ MHz

$F < 8$ dB 1)

1) The local oscillator is adjusted for a diode current of 2 mA.
I. F. amplifier noise $F_{if} = 1,5$ dB; $f = 35$ MHz.

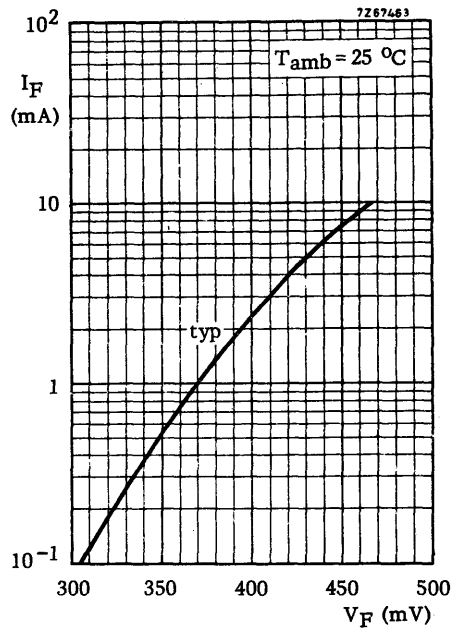

SILICON P-I-N DIODE

Primarily for use in controlled attenuators in v.h.f. and u.h.f. television tuners.

QUICK REFERENCE DATA			
Continuous reverse voltage	V_R	max.	30 V
Forward current (d.c.)	I_F	max.	20 mA
Operating ambient temperature	T_{amb}	max.	60 °C
Diode capacitance $V_R = 0$; $f = 900$ MHz	C_d	typ.	0,3 pF
R.F. forward resistance $I_F = 10 \mu A$; $f = 35$ MHz	r_D	typ.	1,7 k Ω
$I_F = 10$ mA; $f = 35$ MHz	r_D	typ.	4,5 Ω

MECHANICAL DATA

Dimensions in mm

SOD-52

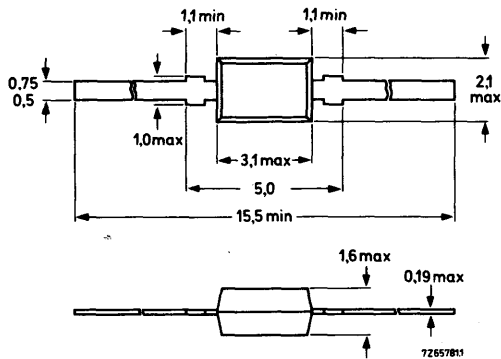

The coloured end indicates the cathode



RATINGS Limiting values in accordance with the Absolute Maximum System (IEC134)

Voltage

Continuous reverse voltage V_R max. 30 V

Current

Forward current (d. c.) I_F max. 20 mA

Temperatures

Storage temperature T_{stg} -55 to +100 °C

Operating ambient temperature T_{amb} max. 60 °C

CHARACTERISTICS at $T_{amb} = 25$ °C

Forward voltage

$I_F = 20$ mA $V_F < 1$ V

Reverse current

$V_R = 10$ V $I_R < 1$ μ A

Diode capacitance

$V_R = 1$ V; $f = 100$ MHz C_d typ. 0,34 pF

$V_R = 0$; $f = 900$ MHz C_d typ. 0,30 pF

R.F. forward resistance

$I_F = 10$ μ A ; $f = 35$ MHz r_D typ. 1,7 k Ω

$I_F = 10$ mA; $f = 35$ MHz r_D typ. 4,5 Ω
 $< 6,5$ Ω

Series inductance 1)

L_s typ. 2 nH

Cross modulation 2)

$f_o = 55$ MHz; $f_{int} = 50$ MHz

$I_F = 50$ μ A V_{int} typ. 0,5 V

1) Measured directly to the envelope.

2) Cross modulation is defined as the interfering voltage with 80% modulation depth over the p-i-n diode, causing 0,8% modulation depth on the wanted signal. (K = 1%)

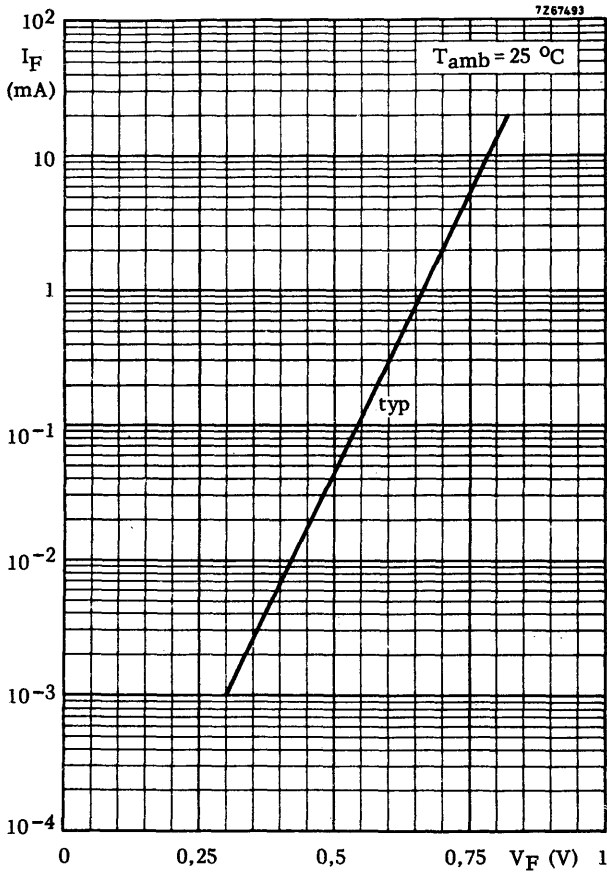

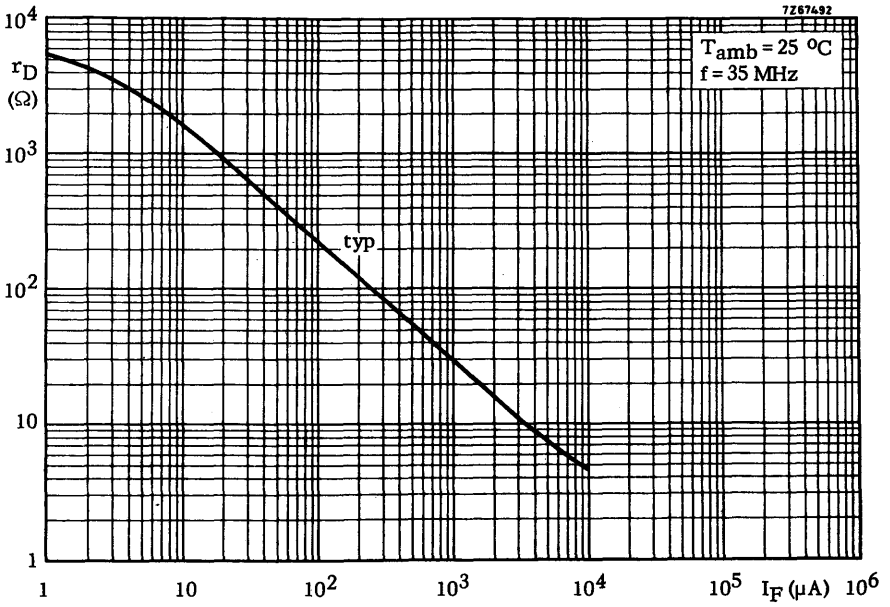

SILICON PLANAR DIODES

Switching diodes in the subminiature DO-34 glass envelope, intended for band switching in v.h.f. television tuners. Special feature of the diodes is their low capacitance.

QUICK REFERENCE DATA

Continuous reverse voltage	V_R	max.	35 V
Forward current (d.c.)	I_F	max.	100 mA
Junction temperature	T_j	max.	150 °C
Diode capacitance			
$V_R = 3 \text{ V}; f = 1 \text{ to } 100 \text{ MHz}$	C_d	< 1,2	1,0 pF
Series resistance at $f = 200 \text{ MHz}$			
$I_F = 3 \text{ mA}$	r_D	< 0,7	1,2 Ω
$I_F = 10 \text{ mA}$	r_D	typ. 0,4	0,5 Ω

MECHANICAL DATA

Dimensions in mm

Fig. 1 SOD-58 (DO-34).

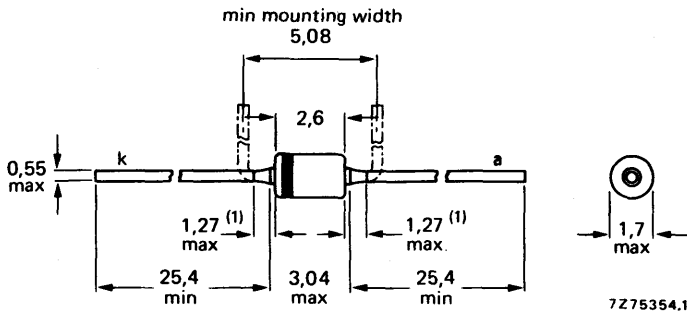

(1) Lead diameter in this zone uncontrolled.

Cathode indicated by coloured band.

BA482: red on a natural background.

BA483: orange on a natural background.



RATINGS

Limiting values in accordance with the Absolute Maximum System (IEC 134)

Continuous reverse voltage	V_R	max.	35 V
Forward current (d.c.)	I_F	max.	100 mA
Storage temperature	T_{stg}		-65 to + 150 °C
Junction temperature	T_j	max.	150 °C

THERMAL RESISTANCE

From junction to ambient mounted on printed board
lead length = 5,0 mm

$R_{th\ j-a}$	=	0,6 °C/mW
---------------	---	-----------

CHARACTERISTICS

$T_j = 25$ °C unless otherwise specified

Forward voltage

$I_F = 100$ mA

V_F	<	1,2 V
-------	---	-------

Reverse current

$V_R = 20$ V

$V_R = 20$ V; $T_{amb} = 75$ °C

I_R	<	100 nA
I_R	<	1 μ A

Diode capacitance

$V_R = 3$ V; $f = 1$ to 100 MHz

		BA482	BA483
C_d	typ.	0,8	0,7 pF
	<	1,2	1,0 pF

Series resistance at $f = 200$ MHz

$I_F = 3$ mA

r_D	typ.	0,6	0,8 Ω
	<	0,7	1,2 Ω

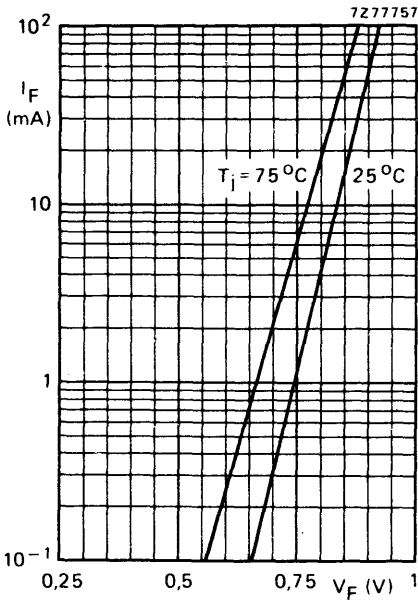

Fig. 2 Typical values.

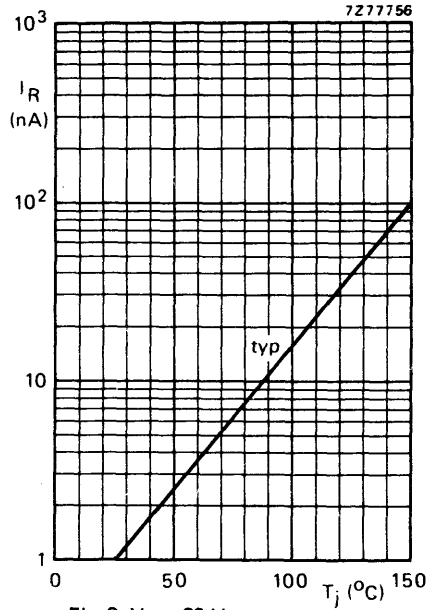

Fig. 3 $V_R = 20$ V.

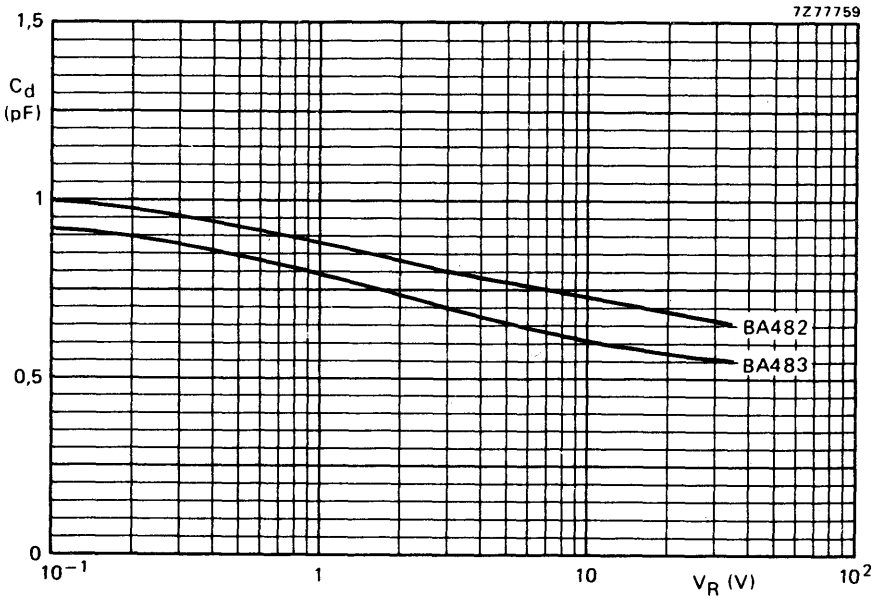

Fig. 4 Typical values; $f = 1$ to 100 MHz; $T_j = 25^\circ\text{C}$.

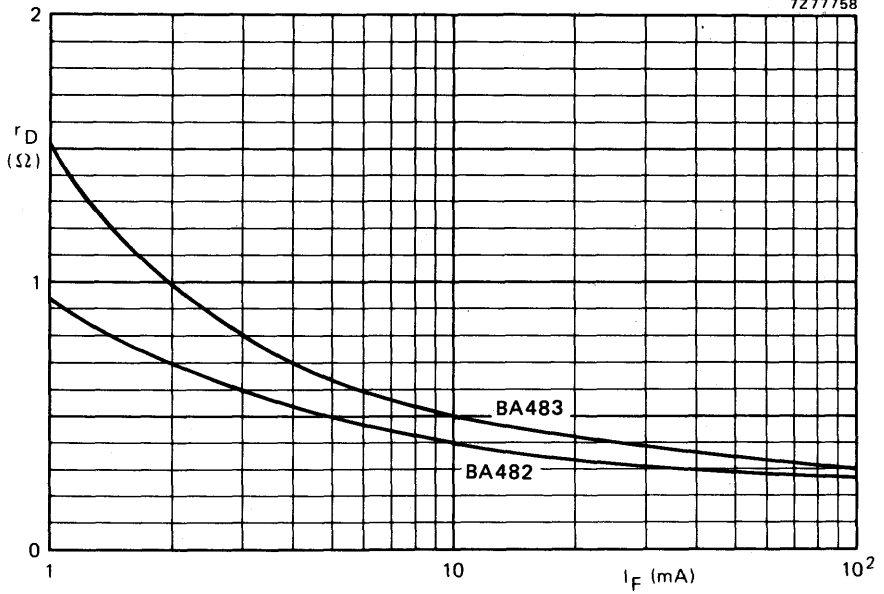

Fig. 5 Typical values; $f = 200$ MHz; $T_j = 25$ °C.

SILICON PLANAR VARIABLE CAPACITANCE DIODES

The BB105B and BB105G are variable capacitance diodes in plastic envelopes. The BB105B is meant for u.h.f. tuners up to frequencies of 860 MHz. The BB105G is intended for use in v.h.f. tuners. Diodes will be supplied in matched sets. The capacitance difference between any two diodes in one set is less than 3% for the BB105B, and less than 6% for the BB105G, over the voltage range from 0,5 V to 28 V. These diodes are supplied in minimum quantities of 6000.

QUICK REFERENCE DATA

Continuous reverse voltage	V_R	max.	28	V
Reverse current at $V_R = 28$ V	I_R	<	10	nA
Diode capacitance at $f = 1$ MHz $V_R = 25$ V	C_d	>	2,0	1,8 pF
		<	2,3	2,8 pF
Capacitance ratio at $f = 1$ MHz	$\frac{C_d(V_R = 3\text{ V})}{C_d(V_R = 25\text{ V})}$	>	4,5	4
		<	6,0	6
Series resistance at $f = 470$ MHz V_R is that value at which $C_d = 9$ pF	r_D	typ.	0,7	0,9 Ω
		<	0,8	1,2 Ω

MECHANICAL DATA

Dimensions in mm

Fig. 1 SOD-23.

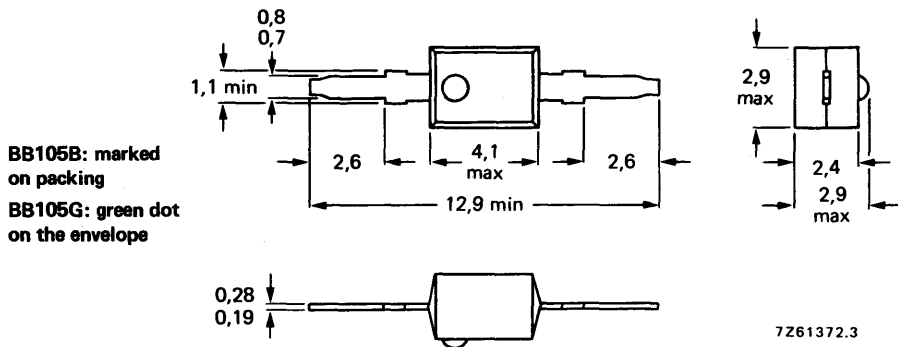

The white band indicates the cathode.

Available for current production only; not recommended for new designs.

The sealing of the plastic envelope withstands the accelerated damp heat test of IEC recommendation 68-2 (test D, severity IV, 6 cycles).



RATINGS

Limiting values in accordance with the Absolute Maximum System (IEC 134)

Continuous reverse voltage	V_R	max.	28	V
Reverse voltage (peak value)	V_{RM}	max.	30	V
Forward current (d.c.)	I_F	max.	20	mA
Storage temperature	T_{stg}		-55 to + 100	°C
Operating junction temperature	T_j	max.	85	°C

THERMAL RESISTANCE

From junction to ambient in free air	$R_{th\ j-a}$	=	0,4	°C/mW
--------------------------------------	---------------	---	-----	-------

CHARACTERISTICS

$T_j = 25\text{ °C}$ unless otherwise specified

Reverse current

$V_R = 28\text{ V}$	I_R	<	10	nA	←
$V_R = 28\text{ V}; T_{amb} = 85\text{ °C}$	I_R	<	200	nA	←

Diode capacitance at $f = 1\text{ MHz}$

			BB105B	BB105G	
$V_R = 1\text{ V}$	C_d	typ.	17,5	17,5	pF
$V_R = 3\text{ V}$	C_d	typ.	11,5	11,5	pF
$V_R = 25\text{ V}$	C_d	>	2,0	1,8	pF
		<	2,3	2,8	pF

Capacitance ratio at $f = 1\text{ MHz}$

$\frac{C_d(V_R = 3\text{ V})}{C_d(V_R = 25\text{ V})}$	>	4,5	4
	<	6,0	6

Series resistance

at $f = 470\text{ MHz}$ and at that value of V_R at which $C_d = 9\text{ pF}$

r_D	typ.	0,7	0,9	Ω
	<	0,8	1,2	Ω

at $f = 200\text{ MHz}$ and $I_F \cong 5\text{ mA}$

r_D	typ.	0,4	0,4	Ω
-------	------	-----	-----	----------

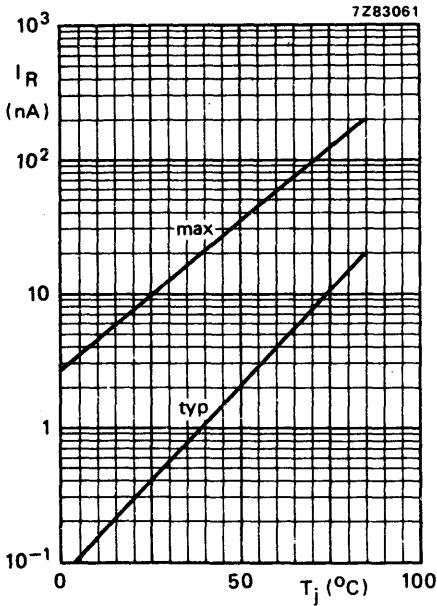

Fig. 2 $V_R = 28$ V.

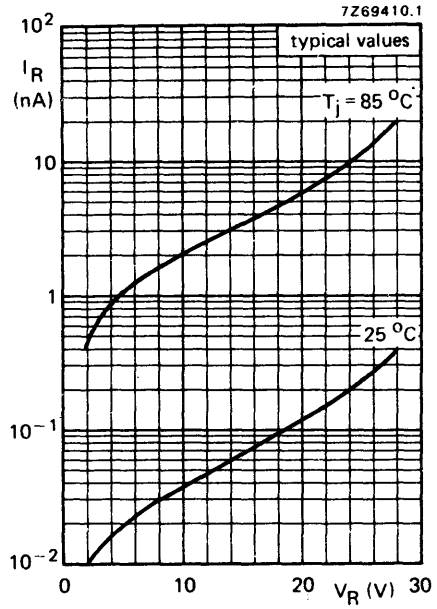

Fig. 3.

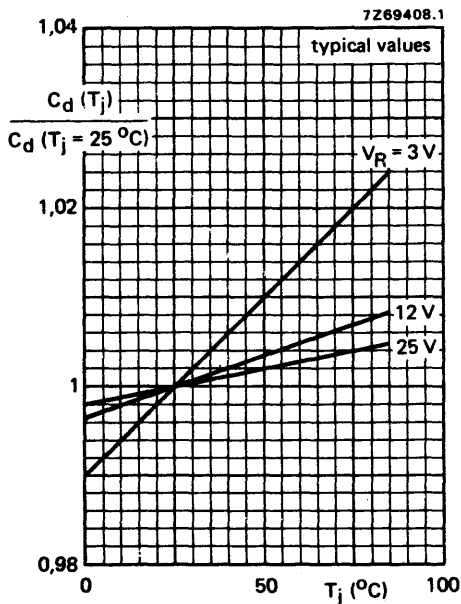

Fig. 4.

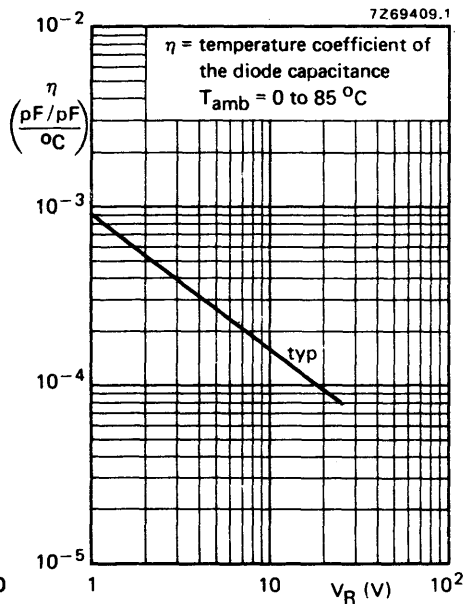
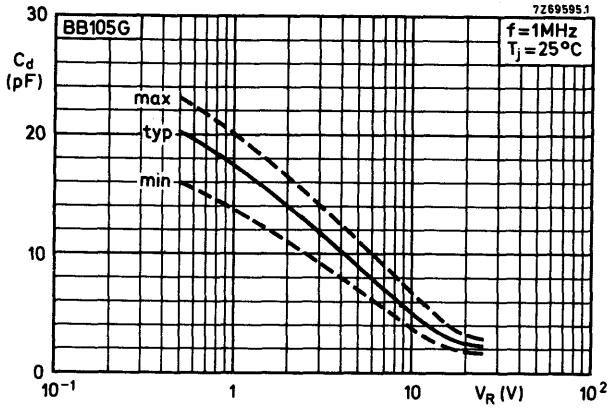
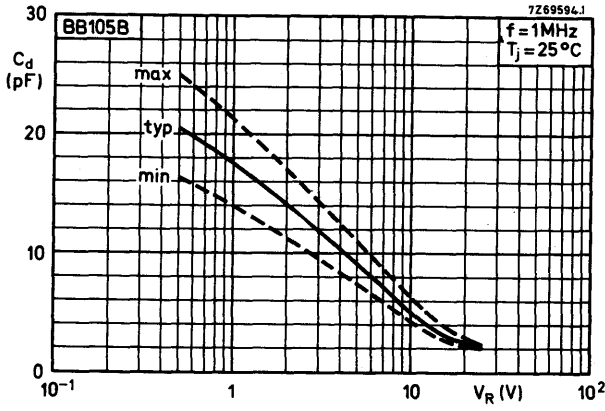

Fig. 5.

BB105B
BB105G



SILICON PLANAR VARIABLE CAPACITANCE DIODES

The BB110B and BB110G are variable capacitance diodes in a plastic envelope primarily intended for electronic tuning in band II (f.m.). They are recommended for r.f. and interstage circuits.

QUICK REFERENCE DATA				
Continuous reverse voltage	V_R	max.	30	V
Junction temperature	T_j	max.	100	$^{\circ}\text{C}$
Reverse current at $V_R = 30\text{ V}$	I_R	<	20	nA
Diode capacitance at $f = 1\text{ MHz}$ $V_R = 3\text{ V}$	C_d	BB110G BB110B		pF
		27 - 31 29 - 33		
Capacitance ratio	$\frac{C_d(V_R = 3\text{ V})}{C_d(V_R = 30\text{ V})}$	2,5 to 2,8		
Series resistance at $f = 100\text{ MHz}$ V_R is that value at which $C_d = 30\text{ pF}$	r_D	typ.	0,3	Ω
		<	0,4	Ω

MECHANICAL DATA

Dimensions in mm

SOD-23

BB110B: blue dot

BB110G: green dot

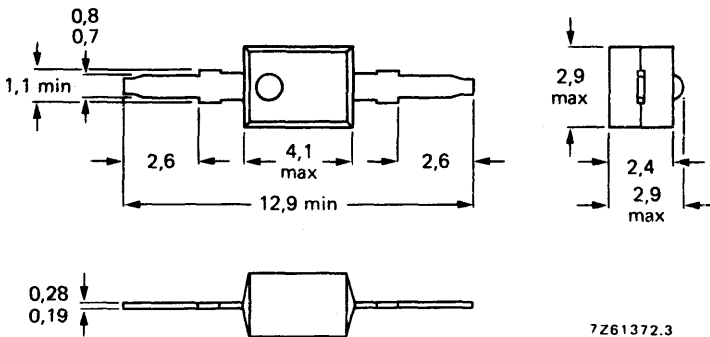

The violet band indicates the cathode

The sealing of the plastic envelope withstands the accelerated damp heat test of IEC recommendation 68-2 (test D, severity IV, 6 cycles).

Available for current production only; not recommended for new designs.



RATINGS Limiting values in accordance with the Absolute Maximum System (IEC 134)

Voltage

Continuous reverse voltage V_R max. 30 V

Current

Forward current (d. c.) I_F max. 100 mA

Temperatures

Storage temperature T_{stg} - 55 to +100 °C

Junction temperature T_j max. 100 °C

THERMAL RESISTANCE

From junction to ambient in free air $R_{th\ j-a}$ = 0,4 °C/mW

CHARACTERISTICS

$T_j = 25$ °C unless otherwise specified

Reverse current at $V_R = 30$ V I_R typ. 1 nA
< 20 nA

$V_R = 30$ V; $T_j = 60$ °C I_R typ. 5 nA
< 200 nA

Diode capacitance at $f = 1$ MHz

$V_R = 3$ V

$V_R = 30$ V

	BB110G	BB110B	
C_d	27-31	29-33	pF
C_d	typ. 11		pF

→ Capacitance ratio at $f = 1$ MHz

$\frac{C_d(V_R = 3\text{ V})}{C_d(V_R = 30\text{ V})}$ 2,5 to 2,8

Series resistance at $f = 100$ MHz

V_R is that value at which $C_d = 30$ pF

r_D typ. 0,3 Ω
< 0,4 Ω

Temperature coefficient of the diode capacitance

$V_R = 3$ V

η typ. 0,04 %/°C

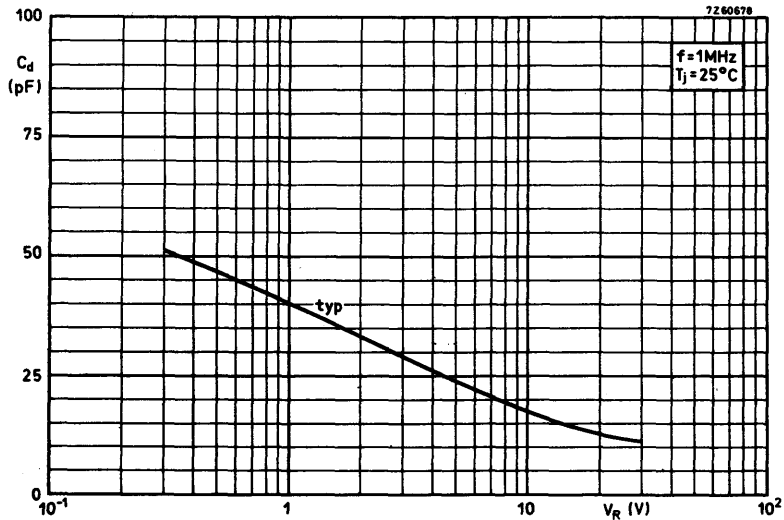
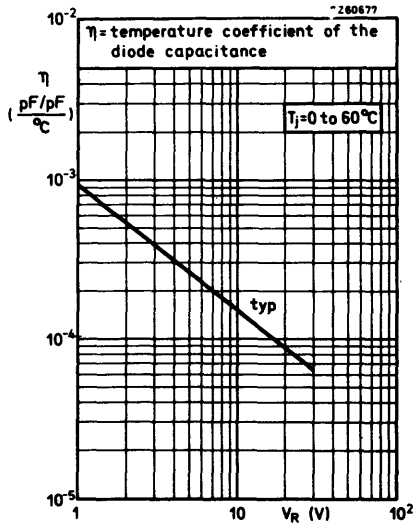
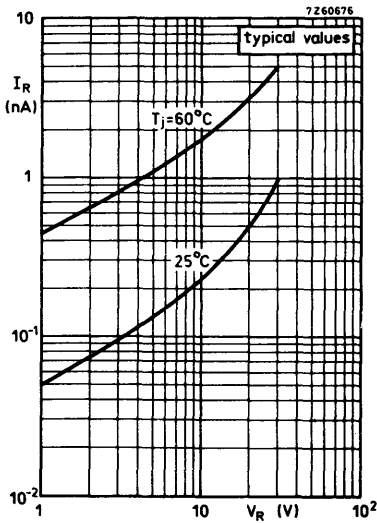

SILICON VARIABLE CAPACITANCE DIODE

Planar-diffused diode in a DO-35 envelope intended for automatic frequency control in radio and television receivers.

QUICK REFERENCE DATA			
Continuous reverse voltage	V_R	max. 15	V
Junction temperature	T_j	max. 200	°C
Reverse current at $V_R = 15$ V; $T_j = 150$ °C	I_R	< 2,0	µA
Diode capacitance at $f = 1$ MHz $V_R = 4$ V	C_d	20 to 25	pF
Capacitance ratio at $f < 300$ MHz	$\frac{C_d(V_R = 4 \text{ V})}{C_d(V_R = 10 \text{ V})}$	≥ 1,3	
Series resistance at $V_R = 4$ V; $f = 200$ MHz	r_D	< 1,5	Ω

MECHANICAL DATA

Dimensions in mm

DO-35

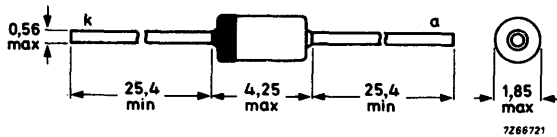

The coloured band indicates the cathode

The diodes are type-branded



RATINGS Limiting values in accordance with the Absolute Maximum System (IEC 134)

Voltage

Continuous reverse voltage V_R max. 15 V

Current

Forward current (d. c.) I_F max. 200 mA

Temperatures

Storage temperature T_{stg} -65 to +200 °C

Junction temperature T_j max. 200 °C

THERMAL RESISTANCE

From junction to ambient in free air

CHARACTERISTICS

$T_j = 25$ °C unless otherwise specified

Reverse current

$V_R = 15$ V; $T_j = 150$ °C $I_R < 2,0$ μ A

Forward voltage

$I_F = 100$ mA $V_F < 950$ mV

Diode capacitance at $f = 1$ MHz

$V_R = 4$ V C_d 20 to 25 pF

Capacitance ratio at $f < 300$ MHz

$\frac{C_d(V_R = 4 \text{ V})}{C_d(V_R = 10 \text{ V})} \geq 1,3$

Series resistance at $f = 200$ MHz

$V_R = 4$ V r_D typ. 0,9 Ω
< 1,5 Ω

Simplified equivalent circuit:

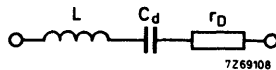

L = lead inductance ≈ 6 nH

r_D = series resistance

C_d = diode capacitance (see page 3)

frequency independent

up to $f = 300$ MHz

These data apply for a distance of 10 mm between the two measuring points.

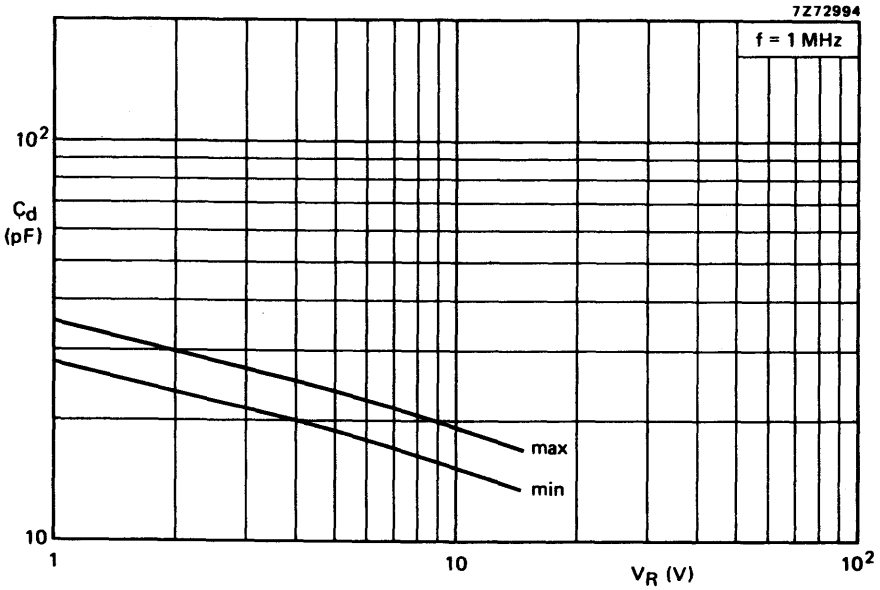
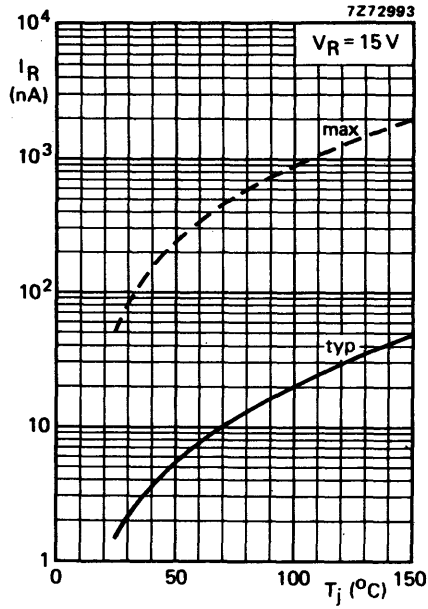

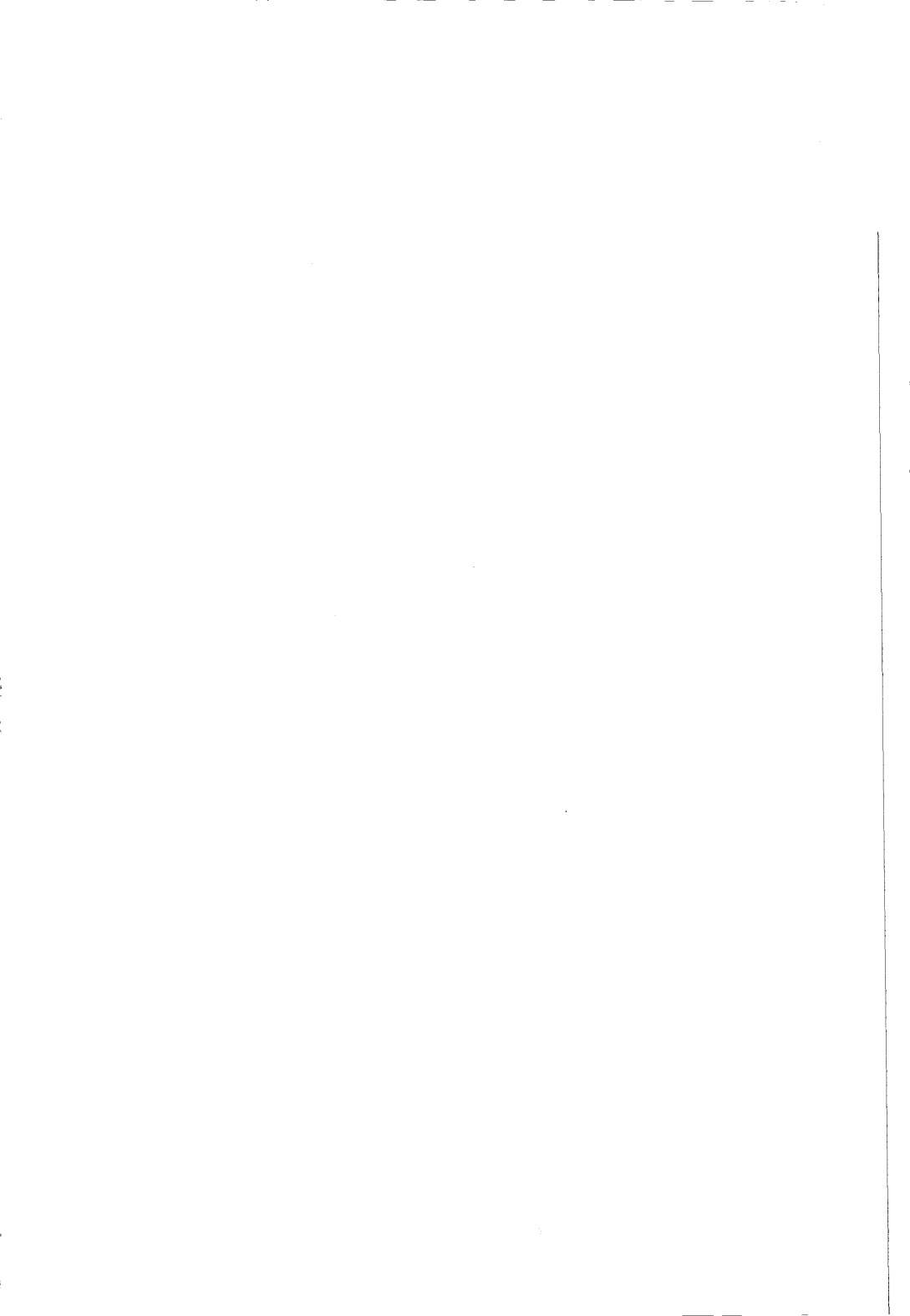

A.M. VARIABLE CAPACITANCE DOUBLE DIODES

The BB212 is a silicon mesa profiled epitaxial double tuning diode with common cathode in a plastic TO-92 variant.

A special feature is the low tuning voltage which makes the device particularly suited to car and domestic receivers in the L.W., M.W. and S.W. bands.

QUICK REFERENCE DATA

For each diode:

Continuous reverse voltage	V_R	max.	12 V
Operating junction temperature	T_j	max.	85 °C
Reverse current at $T_j = 25$ °C $V_R = 10$ V	I_R	<	50 nA
Diode capacitance at $f = 1$ MHz $V_R = 0,5$ V	C_d		500 to 620 pF
$V_R = 8,0$ V	C_d	<	22 pF
Capacitance ratio at $f = 1$ MHz	$\frac{C_d(V_R = 0,5 V)}{C_d(V_R = 8,0 V)}$		23 to 36
Series resistance at $f = 500$ kHz V_R is that value at which $C_d = 500$ pF	r_D	<	2,5 Ω

MECHANICAL DATA

Dimensions in mm

Fig. 1 TO-92 variant.

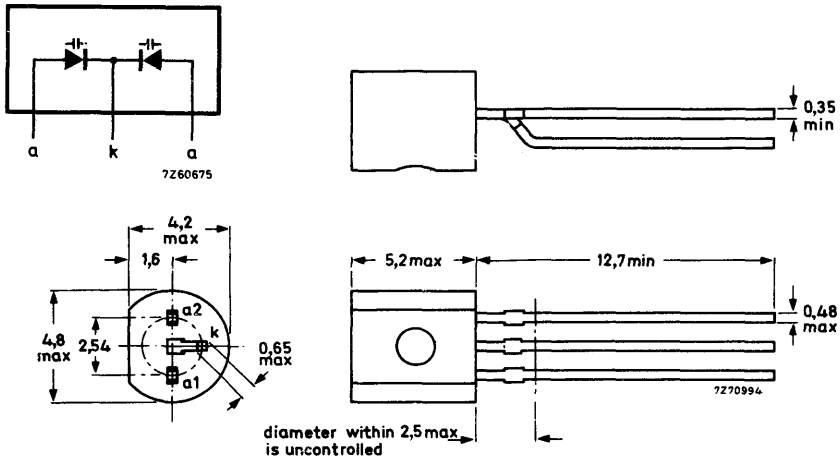

The anode of the diode with the higher capacitance C_1 at $V_R = 3$ V, i.e. a more positive mismatch, is identified by a white dot.



RATINGS (for each diode)

Limiting values in accordance with the Absolute Maximum System (IEC 134)

Continuous reverse voltage	V_R	max.	12 V
Forward current (d.c.)	I_F	max.	100 mA
Storage temperature	T_{stg}		-55 to + 100 °C
Operating junction temperature	T_j	max.	85 °C

CHARACTERISTICS (for each diode)

$T_j = 25$ °C unless otherwise specified

Reverse current

$V_R = 10$ V	I_R	<	50 nA
$V_R = 10$ V; $T_{amb} = 60$ °C	I_R	<	200 nA

Diode capacitance at $f = 1$ MHz

$V_R = 0,5$ V	C_d		500 to 620 pF
$V_R = 3,0$ V	C_d	>	140 pF
$V_R = 5,5$ V	C_d	>	40 pF
$V_R = 8,0$ V	C_d	<	22 pF

Capacitance ratio at $f = 1$ MHz

$\frac{C_d(V_R = 0,5 V)}{C_d(V_R = 8,0 V)}$		23 to 36
---	--	----------

Series resistance at $f = 500$ MHz

→ V_R is that value at which $C_d = 500$ pF	r_D	<	2,5 Ω
---	-------	---	--------------

Temperature coefficient of the diode capacitance

at $f = 1$ MHz; $T_{amb} = 25$ °C to 60 °C

$V_R = 0,5$ V	η	typ.	0,054 %/°C
$V_R = 8,0$ V	η	typ.	0,050 %/°C

MATCHING PROPERTIES

The capacitance of the two diodes in their common envelope may differ within certain limits. The total, relative capacitance difference between the two diodes in one envelope may be found in Fig. 2. The anode a1 or a2 with the higher capacitance at $V_R = 3$ V, is identified by a white dot.

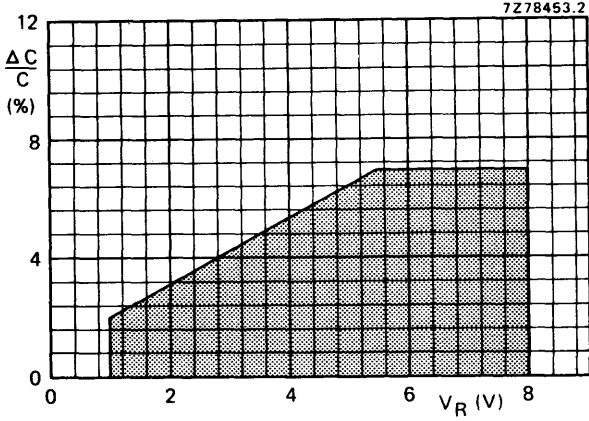

Fig. 2 The shaded area represents the maximum tolerance of the two diodes in one envelope as a function of the reverse voltage.

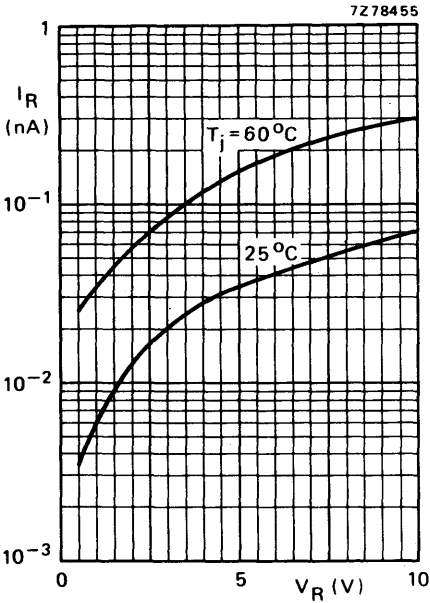

Fig. 3 Typical values.

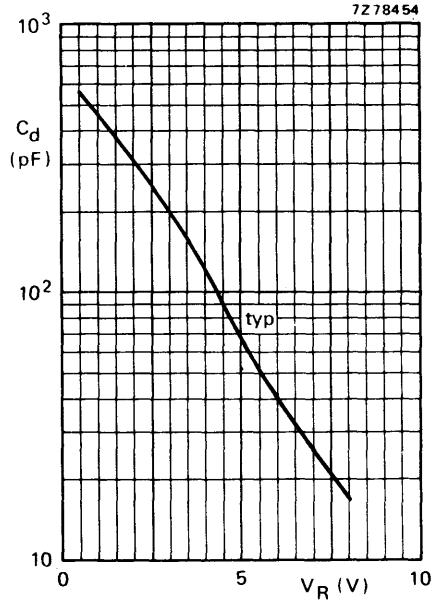

Fig. 4 $f = 1$ MHz.



VARIABLE CAPACITANCE DIODES

The BB405B and BB405G are silicon variable capacitance diodes in hermetically sealed glass DO-34 envelopes.

The BB405B is intended for u.h.f. tuning up to frequencies of 860 MHz. The BB405G is intended for v.h.f. tuning.

Diodes are supplied in matched sets and the capacitance difference between any two diodes in one set is less than 3% over the voltage range from 0,5 V to 28 V.

QUICK REFERENCE DATA

Continuous reverse voltage	V_R	max.	28 V
Reverse current at $V_R = 28$ V	I_R	<	10 nA ←
Diode capacitance at $f = 500$ kHz $V_R = 25$ V	C_d	>	2,0 pF
		<	2,3 pF
Capacitance ratio at $f = 500$ kHz	$C_d (V_R = 3$ V)	>	4,8 ←
		$C_d (V_R = 25$ V)	<
Series resistance at $f = 470$ MHz V_R is that value at which $C_d = 9$ pF	r_D	<	0,8 Ω

MECHANICAL DATA

Fig. 1 SOD-68 (DO-34).

Dimensions in mm

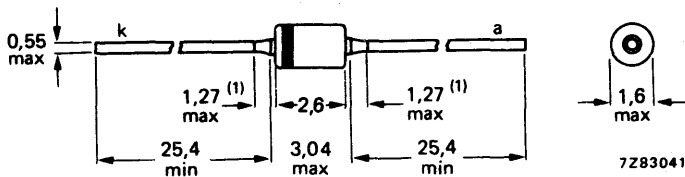

(1) Lead diameter in this zone uncontrolled.

The diodes are suitable for mounting on a 2E (5,08 mm) pitch.

BB405B: white cathode ring; body black coloured

BB405G: additional green band.

Maximum soldering iron or solder bath temperature 300 °C; maximum soldering time 3 s. Distance from case is not critical, but the glass envelope must not come into contact with soldering iron.



BB405B
BB405G

RATINGS

Limiting values in accordance with the Absolute Maximum System (IEC 134)

Continuous reverse voltage	V_R	max.	28 V
Reverse voltage (peak value)	V_{RM}	max.	30 V
Forward current (d.c.)	I_F	max.	20 mA
Storage temperature	T_{stg}		-55 to + 150 °C ←←
Operating junction temperature	T_j	max.	100 °C ←←

CHARACTERISTICS

$T_{amb} = 25$ °C unless otherwise specified

Reverse current

$V_R = 28$ V

$V_R = 28$ V; $T_{amb} = 85$ °C

Diode capacitance at $f = 500$ kHz*

$V_R = 1$ V

$V_R = 3$ V

$V_R = 25$ V

Capacitance ratio at $f = 500$ kHz

Series resistance

at $f = 470$ MHz and at that value of V_R at which $C_d = 9$ pF

		BB405B	BB405G	
I_R	<	10	10	nA
I_R	<	1	1	μA ←
C_d	typ.	17	17	pF
C_d	typ.	11,5	11,5	pF
C_d	>	2,0	1,8	pF
C_d	<	2,3	2,5	pF
$\frac{C_d(V_R = 3\text{ V})}{C_d(V_R = 25\text{ V})}$	>	4,8	4,3	←
$\frac{C_d(V_R = 3\text{ V})}{C_d(V_R = 25\text{ V})}$	<	5,8	6,0	
r_D	<	0,8	1,2	Ω

* Matching: Devices are supplied on a bandolier with a space between matched sets (minimum quantity 120 devices, total divisible by 12; maximum quantity is 6000 per reel). Capacitance difference between any two diodes in one set is less than 3% over the voltage range from 0,5 V to 28 V.

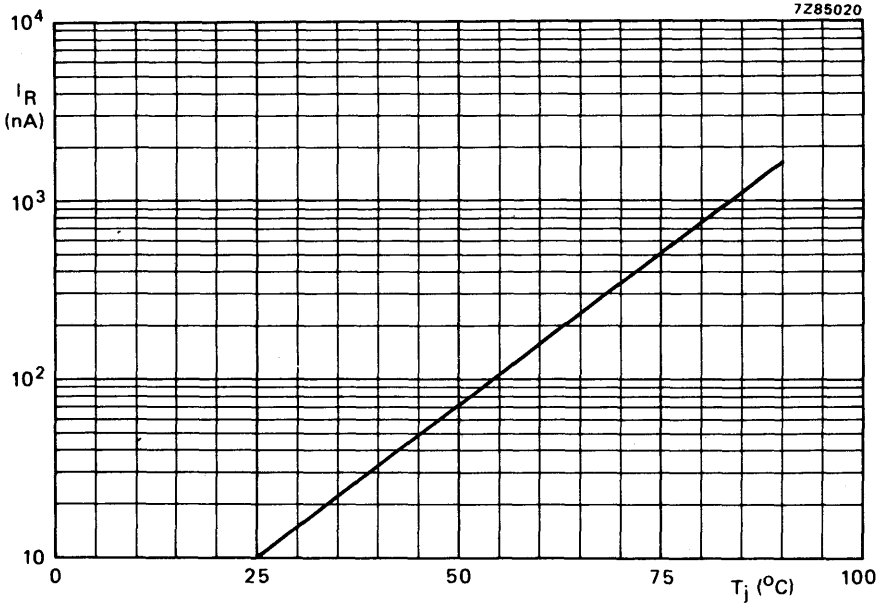

Fig. 2 Reverse current as a function of the junction temperature.

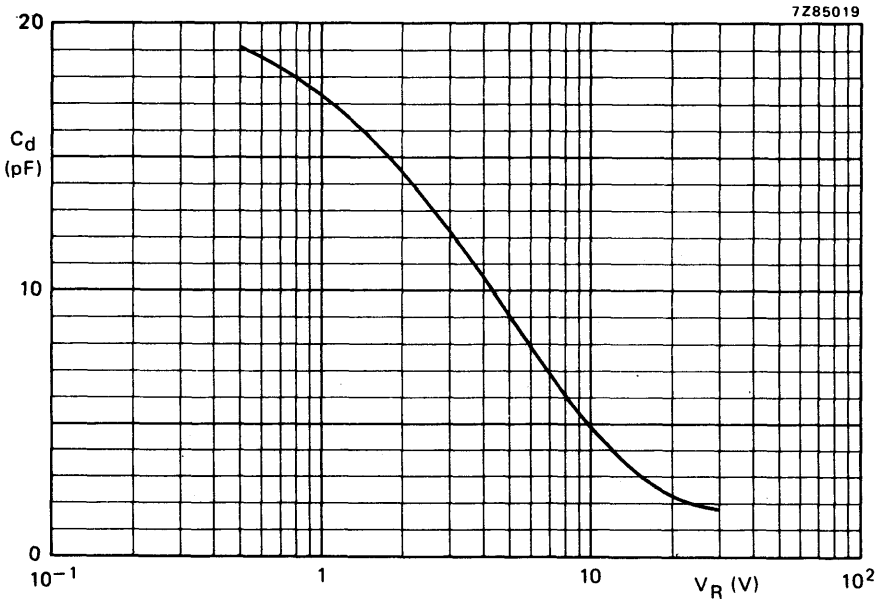
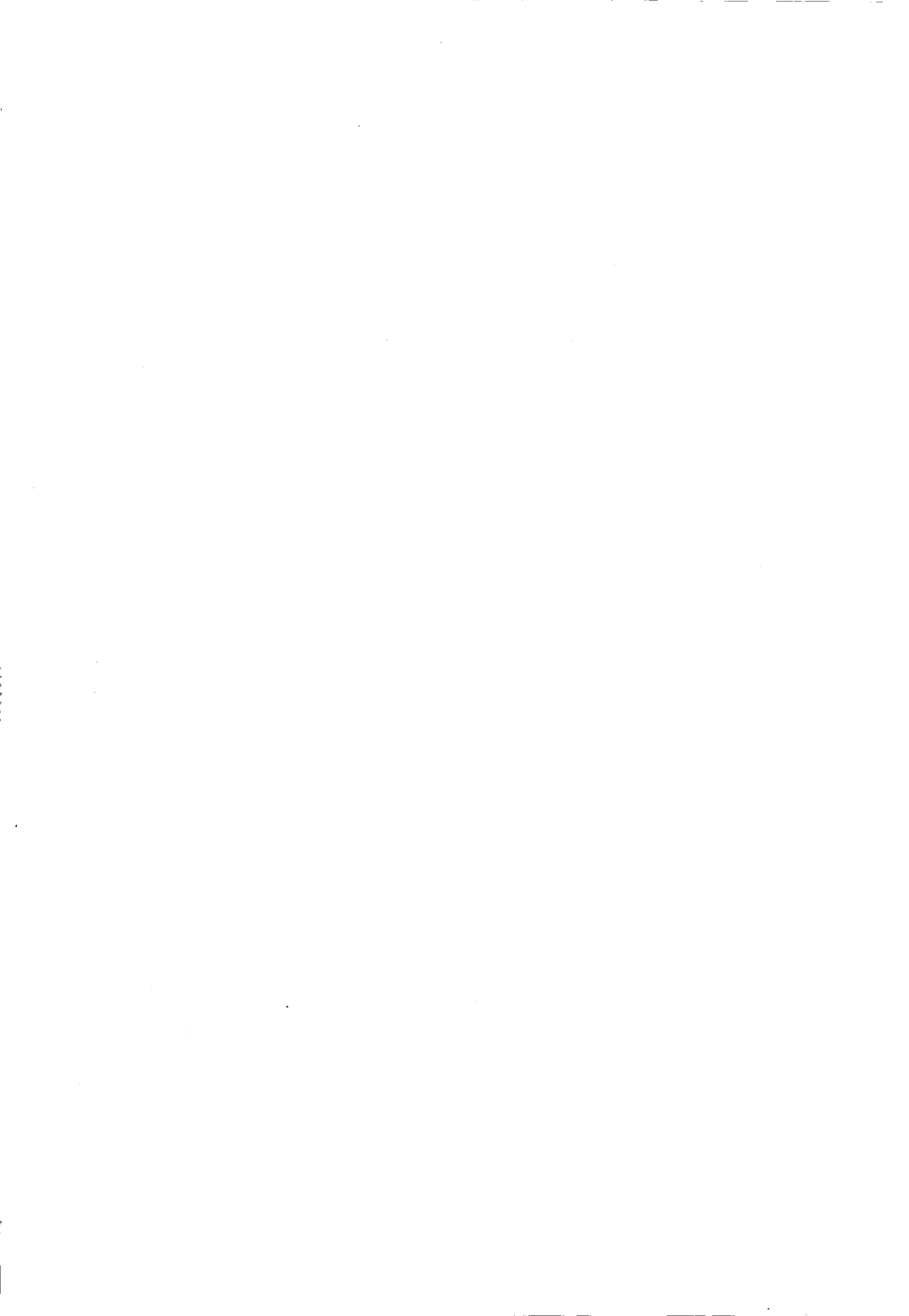

Fig. 3 Diode capacitance at $f = 500$ kHz.



SILICON PLANAR VARIABLE CAPACITANCE DIODE

The BB809 is a variable capacitance diode in a glass envelope intended for electronic tuning in v.h.f. television tuners with extended band I (FCC and OIRT-norm).

Diodes are supplied in matched sets (minimum 120 pieces and divisible by 12) and the capacitance difference between any two diodes in one set is less than 3% over the voltage range from 0,5 V to 28 V.

QUICK REFERENCE DATA

Continuous reverse voltage	V_R	max.	28 V
Reverse current at $V_R = 28$ V	I_R	<	10 nA
Diode capacitance at $f = 500$ kHz	$V_R = 3$ V	C_d	26 to 32 pF
	$V_R = 25$ V	C_d	4,5 to 6 pF
Capacitance ratio at $f = 500$ kHz	$\frac{C_d (V_R = 3 \text{ V})}{C_d (V_R = 25 \text{ V})}$		5 to 6,5
	Series resistance at $f = 200$ MHz	r_D	< 0,6 Ω
V_R is that value at which $C_d = 25$ pF			

MECHANICAL DATA

Dimensions in mm

Fig. 1 SOD-68 (DO-34).

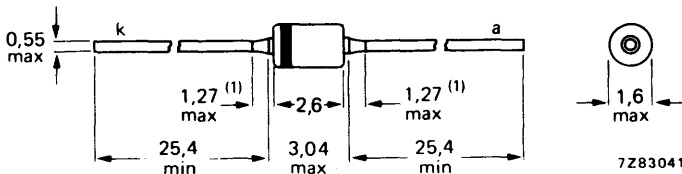

(1) Lead diameter in this zone uncontrolled.

Cathode indicated by yellow band.

Maximum soldering iron or solder bath temperature 300 °C; maximum soldering time 3 s. Distance from case is not critical, but the glass envelope must not come into contact with soldering iron.



RATINGS

Limiting values in accordance with the Absolute Maximum System (IEC 134)

Continuous reverse voltage	V_R	max.	28 V
Reverse voltage (peak value)	V_{RM}	max.	30 V
Forward current (d.c.)	I_F	max.	20 mA
Storage temperature	T_{stg}		-55 to + 150 °C
Operating junction temperature	T_j	max.	100 °C

THERMAL RESISTANCE

From junction to ambient in free air	$R_{th\ j-a}$	=	0,6 °C/mW
--------------------------------------	---------------	---	-----------

CHARACTERISTICS

$T_{amb} = 25\text{ °C}$ unless otherwise specified

Reverse current

$V_R = 28\text{ V}$	I_R	<	10 nA
---------------------	-------	---	-------

$V_R = 28\text{ V}; T_{amb} = 85\text{ °C}$	I_R	<	200 nA
---	-------	---	--------

Diode capacitance at $f = 500\text{ kHz}$

$V_R = 3\text{ V}$	C_d		26 to 32 pF
--------------------	-------	--	-------------

$V_R = 25\text{ V}$	C_d		4,5 to 6 pF
---------------------	-------	--	-------------

Capacitance ratio at $f = 500\text{ kHz}$

$\frac{C_d (V_R = 3\text{ V})}{C_d (V_R = 25\text{ V})}$			5 to 6,5
--	--	--	----------

Series resistance at $f = 200\text{ MHz}$

V_R is that value at which $C_d = 25\text{ pF}$	r_D	<	0,6 Ω
---	-------	---	--------------



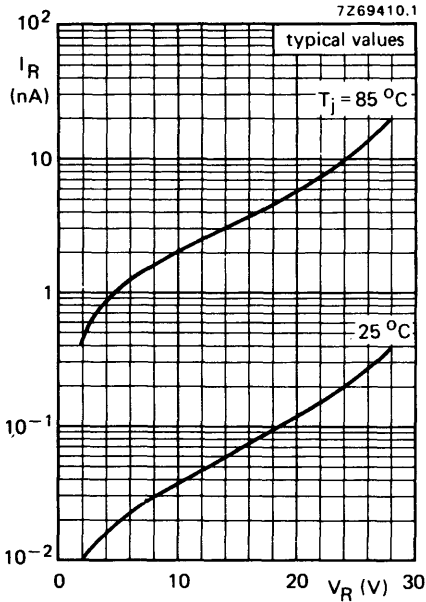

Fig. 2 Typical values.

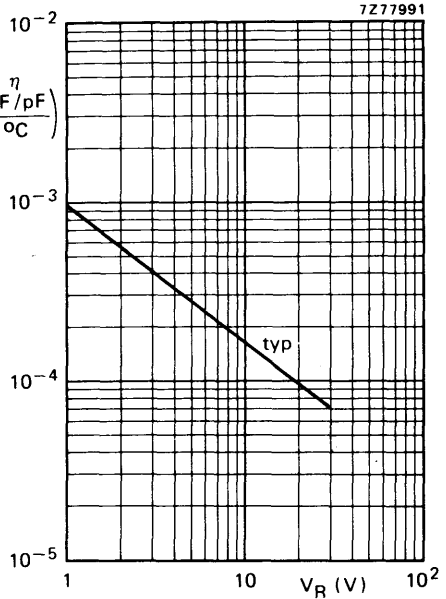

Fig. 3 Temperature coefficient of the diode capacitance; $T_{\text{amb}} = 0$ to 85°C .

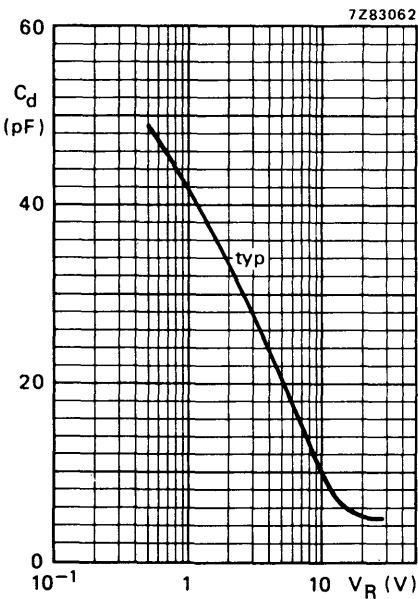

Fig. 4 $f = 500$ kHz; $T_{\text{amb}} = 25^\circ\text{C}$.

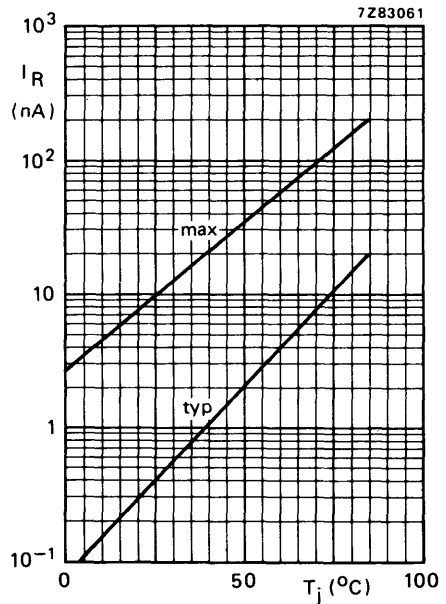

Fig. 5 $V_R = 28$ V.



SPECIAL TYPE





PICOAMPERE DIODE

Silicon diode in a metal envelope. It has an extremely low leakage current over a wide temperature range combined with a low capacitance and is not sensitive for light. It is intended for clamping, holding, peak follower, time delay circuits as well as for logarithmic amplifiers and protection of insulated gate field-effect transistors.

QUICK REFERENCE DATA			
Continuous reverse voltage	V_R	max.	20 V
Forward current (d. c.)	I_F	max.	50 mA
Forward voltage at $I_F = 10$ mA	V_F	<	1.0 V
Reverse current			
$V_R = 5$ V; $T_j = 25$ °C	I_R	<	5 pA
$V_R = 20$ V; $T_j = 25$ °C	I_R	<	10 pA
Diode capacitance			
$V_R = 0$; $f = 1$ MHz	C_d	<	1.3 pF

MECHANICAL DATA

Dimensions in mm

TO-18 (except for the two leads)

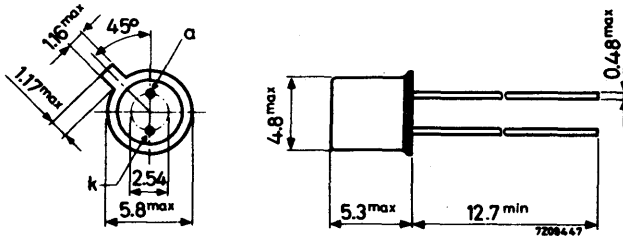

Handle the device with care during soldering into the circuit. The extremely low leakage current can only be guaranteed when the bottom is free from solder flux or other contaminations.



RATINGS Limiting values in accordance with the Absolute Maximum System (IEC 134)Voltages

Continuous reverse voltage	V_R	max.	20	V
Repetitive peak reverse voltage	V_{RRM}	max.	35	V

Currents

Forward current (d. c. or average)	I_F	max.	50	mA
Repetitive peak forward current	I_{FRM}	max.	100	mA

Temperatures

Storage temperature	T_{stg}	-65 to +125	°C
Junction temperature	T_j	max.	125 °C

THERMAL RESISTANCE

From junction to ambient in free air	$R_{th\ j-a}$	=	0.5	°C/mW
--------------------------------------	---------------	---	-----	-------

CHARACTERISTICS $T_j = 25\text{ °C}$ unless otherwise specifiedForward voltage

$I_F = 10\text{ mA}$	V_F	<	1.0	V
----------------------	-------	---	-----	---

Reverse currents

$V_R = 5\text{ V}$	I_R	<	5	pA
$V_R = 5\text{ V}; T_j = 80\text{ °C}$	I_R	<	250	pA
$V_R = 20\text{ V}$	I_R	<	10	pA

Diode capacitance

$V_R = 0; f = 1\text{ MHz}$	C_d	<	1.3	pF
-----------------------------	-------	---	-----	----

$T_j = 25\text{ }^\circ\text{C}$

CHARACTERISTICS (continued)

Forward recovery voltage when switched to

$I_F = 10\text{ mA}$

$V_{fr} < 1,25\text{ V}$

Test circuit and waveforms :

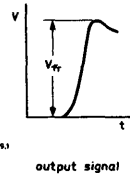
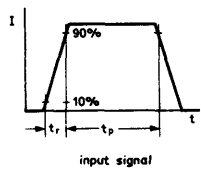
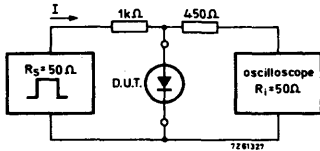

Input signal : Rise time of the forward pulse

$t_r \leq 20\text{ ns}$

Forward current pulse duration

$t_p = 300\text{ ns}$

Duty factor

$\delta = 0,01$

Oscilloscope : Rise time

$t_r = 0,35\text{ ns}$

Input capacitance

$C_i \leq 1\text{ pF}$

Circuit capacitance $C \leq 20\text{ pF}$ ($C = C_i + \text{parasitic capacitance}$)

Reverse recovery time when switched from

$I_F = 10\text{ mA}$ to $I_R = 10\text{ mA}$; $R_L = 100\text{ }\Omega$;

measured at $I_R = 1\text{ mA}$

$t_{rr} < 350\text{ ns}$

Test circuit and waveforms :

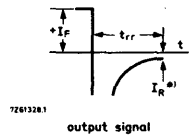
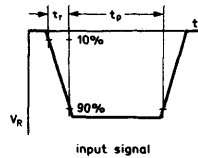
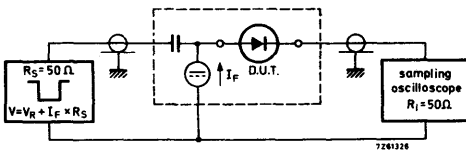

Input signal : Rise time of the reverse pulse

$t_r = 0,6\text{ ns}$

*) $I_R = 1\text{ mA}$

Reverse pulse duration

$t_p = 500\text{ ns}$

Duty factor

$\delta = 0,05$

Oscilloscope : Rise time

$t_r = 0,35\text{ ns}$

Circuit capacitance $C \leq 1\text{ pF}$ ($C = \text{oscilloscope input capacitance} + \text{parasitic capacitance}$)

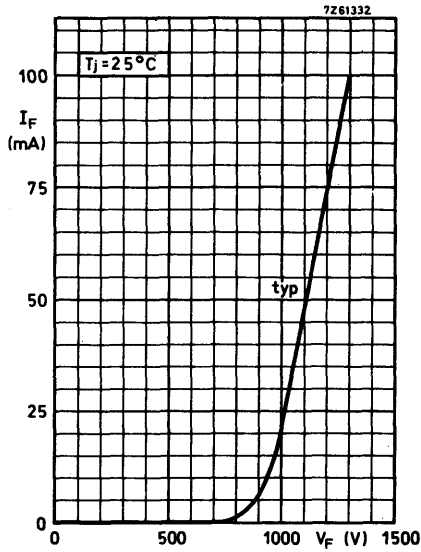
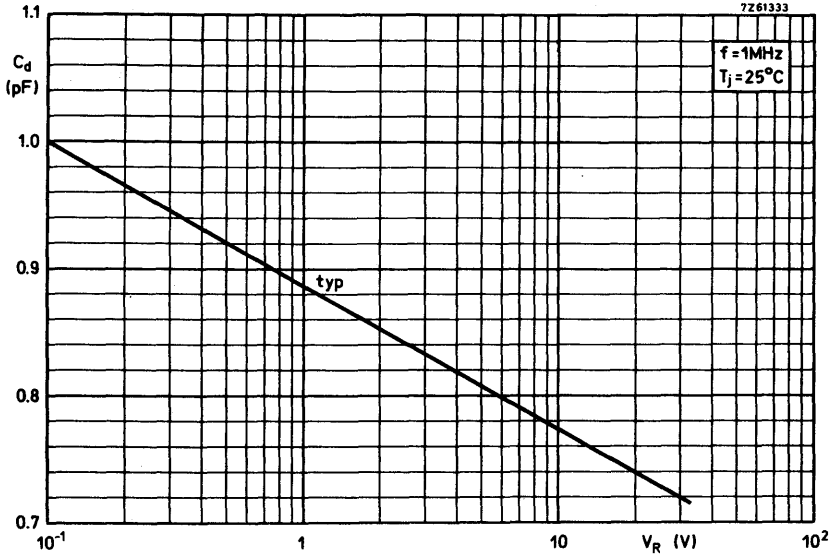

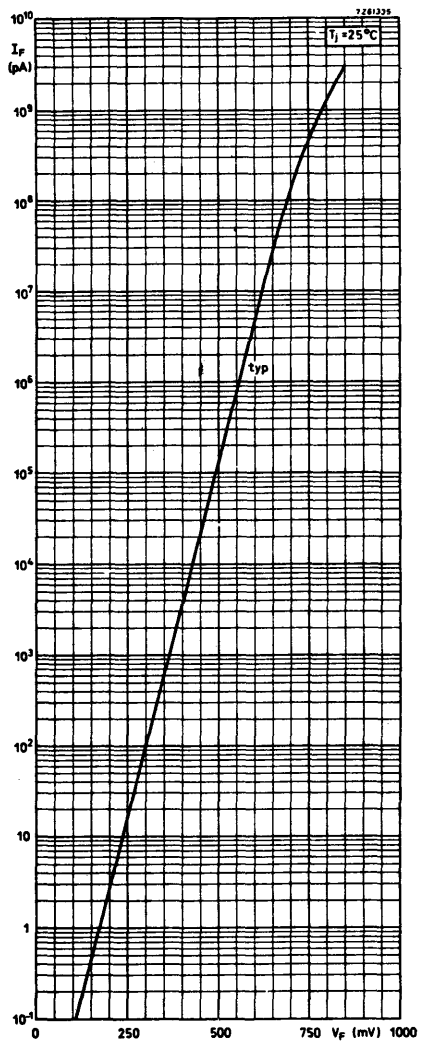

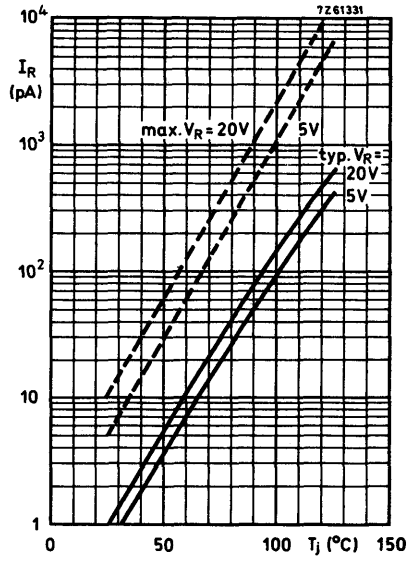
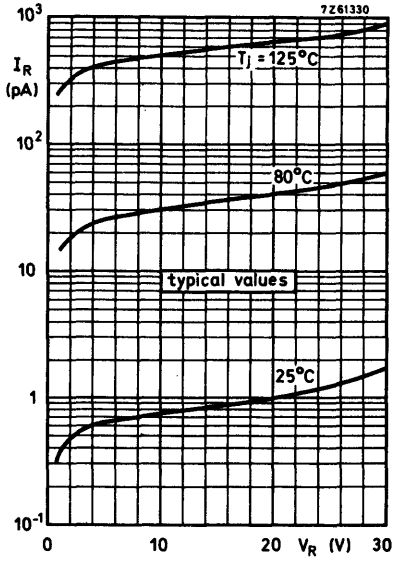

INDEX

INDEX

Type No.	Section	Suggested alternative	Type No.	Section	Suggested alternative
AA119	F*		BY127M	*	BYW56
AAZ13	F*		BY184	E	
AAZ15	F*		BY206	E*	BAS11, BYV95B
AAZ17	F*		BY207	E*	BYV95C
BA182	G*		BY210 series	E*	BYV95/96 series
BA223	G		BY226	*	BYW54
BA243	G		BY227	*	BYW56
BA244	G		BY228	E	
BA280	G		BY409	E	
BA314	C		BY438	E	
BA316	B		BY448	E	
BA317	B		BY458	E	
BA318	B		BY476	E	
BA379	G		BY509	E	
BA482	G		BYV27 series	E	
BA483	G		BYV28 series	E	
BAS11	B		BYV95A,B,C	E	
BAV10	B		BYV96D,E	E	
BAV18	B		BYW54	E	
BAV19	B		BYW55	E	
BAV20	B		BYW56	E	
BAV21	B		BYW95A,B,C	E	
BAV45	H		BYW96D,E	E	
BAW62	B		BYX10	E	
BAX12A	B		BYX36 series	E*	BYW54 to 56
BAX13	B		BYX55 series	E*	BYV95 series
BAX16	B		BYX90	E	
BAX17	B		BYX91 series	E	
BB105B,G	G*		BYX94	*	BYW56
BB110B,G	G*		BZV10	D	
BB119	G		BZV11	D	
BB212	G		BZV12	D	
BB405B,G	G		BZV13	D	
BB809	G		BZV14	D	
BY126M	*	BYW54	BZV46-1V5, 2V0	C	

*Not recommended for the design of new equipment.



Type No.	Section	Suggested alternative	
BZV85 series	C	BZV85 series	
BZX61 series	C*		
BZX79 series	C		
BZX87 series	C		
BZX90	D		
BZX91	D	BA314	
BZX92	D		
BZX93	D		
BZX94	D		
BZY88-COV7	*		
BZY88-C1V3	*		BZV46-1V5
BZY88 series	C		
OA47	F*		
OA90	F*		
OA91	F*		
OA95	F*	B	
OA200	B		
OA202	B		

Type No.	Section	Suggested alternative
1N821	D	
1N823	D	
1N825	D	
1N827	D	
1N829	D	
1N914	B	
1N916	B	
1N4001	E	
1N4002	E	
1N4003	E	
1N4004	E	
1N4005	E	
1N4006	E	
1N4007	E	
1N4148	B	
1N4446	B	
1N4448	B	

*Not recommended for the design of new equipment.



DIODES

CONTENTS

 **SELECTION GUIDE** BS 9000, CECC
approved types

 **A GENERAL SECTION**

B SILICON WHISKERLESS DIODES

C VOLTAGE REGULATOR DIODES (Low power)

D VOLTAGE REFERENCE DIODES

E RECTIFIER DIODES (Low power)

F GERMANIUM DIODES Point contact
Gold bonded

G TUNER DIODES

H SPECIAL TYPE

 **INDEX**

Mullard

Book 1 Part 3

Diodes

Mullard Limited
Mullard House, Torrington Place, London, WC1E 7HD

January 1981



Printed in England
M80-1275